

**Astec Advanced Power Systems**

**UM5C07 ( 169-2071-501 )**

# **Helios Rectifier 50/48 Single Phase –48 V, 50 A Switch Mode Rectifier**

## **NT5C07**

### **Installation and User Manual**

---

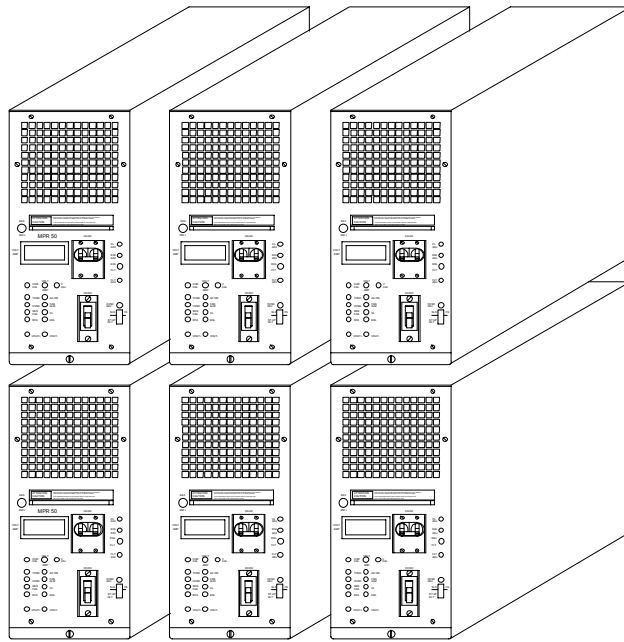

---

P0734780 Standard 12.00 May 2001

Astec Advanced Power Systems  
*A part of Emerson Network Power*





---

# **Helios Rectifier 50/48 Single Phase –48 V, 50 A Switch Mode Rectifier NT5C07 Installation and User Manual**

---

Manual Number : UM5C07 ( 169-2071-501 )  
Manual Issue : 12.00  
Manual Status : Standard  
Release Date : May 2001  
P0734780

---

Copyright ©2001 Astec Advanced Power Systems Ltd  
All Rights Reserved

Published in Canada

The information contained in this manual is the property of Astec Advanced Power Systems and is subject to change without notice. Astec Advanced Power Systems Ltd reserves the right to make changes in design or components as progress in engineering and manufacturing may warrant. Except as specifically authorized in writing by the V.P. of Engineering and Product Manufacturing of Astec Advanced Power Systems Ltd, the holder of this manual shall keep all information contained herein confidential and shall protect same, in whole or in part, from disclosure and dissemination to all third parties, and use the same for start-up, operation, troubleshooting, and maintenance purposes only. Any modification to the equipment must be approved by the person responsible for product safety, and design quality at Astec Advanced Power Systems Ltd to ensure that the equipment complies with the operation standards.

The equipment generates, uses, and can radiate radio frequency energy, and if not installed and used in accordance with the instructions contained in the Installation and User Manuals, can cause harmful interference to radio communications. Operation of this equipment in a residential area is likely to cause harmful interference, in which case the user will be required to correct the interference at his own expense.

Astec Advanced Power Systems  
*A part of Emerson Network Power*

Helios Candeeo is a trademark of Astec International Ltd. The Emerson logo is a trademark and service mark of Emerson Electric Co.



---

## Publication history

---

### **May 2001**

Standard Issue 12.00. Manual modified to reflect Emerson identity.  
( EC 102-26438 )

### **September 1999**

Standard Issue 11.0. Document modified to reflect Astec standards  
(ECN<sup>o</sup>102-17331)

### **April 1999**

Standard Issue 10.0. Document modified to reflect Astec identity.  
(ECN 102-14099)

### **June 1997**

Standard Issue 9.0. Changes in the Float Voltage Adjustment Load  
Shared Adjustment & the Parallel Operation.

### **June 1996**

Standard Issue 8.0. Changes in the Overview, Installation & Start-up  
Procedures & Operations sections.

### **October 1995**

Standard Issue 7.0. This issue is to revise the “Specification” section.

### **September 1995**

Standard Issue 6.0

### **August 1995**

Standard Issue 5.1. This issue is to cover the revision of installation  
and start-up procedures and specifications.

### **February 1995**

Standard Issue 4.0. This issue is to cover a complete revision of the  
Installation Procedure for the Helios Rectifier 50.

### **April 1993**

Standard release 3.0.

**November 1992**

Standard release 2.0.

**February 1992**

Standard release 1.0.

---

# Contents

---

<b>Overview .....</b>	<b>11</b>
Description .....	11
Applications.....	12
Equipment Identification .....	12
MPS150 - NT5C12A(X) - power shelf (23-inch) .....	13
MPS100 - NT5C12B(X) - power shelf (19-inch) .....	14
Helios Rectifier 50/48 NT5C07A(X) -48 V / 50 A Switch Mode Rectifier .....	15
<b>Specifications .....</b>	<b>17</b>
<b>Installation and start-up procedures .....</b>	<b>19</b>
Installation overview .....	19
Tools and test equipment.....	19
Precautions and preparation .....	20
Removing the blank panel .....	21
Power shelf installation .....	22
Power shelf wiring .....	22
Installing the DC conductors .....	25
Control and alarm connections .....	26
Verification .....	28
Rectifier installation .....	29
Start-up and verification.....	29
Equalize Voltage Adjustment (EQL) .....	31
Load Sharing .....	31
Current Limit Verification (CL) .....	31
Start up delay .....	31
<b>Operation .....</b>	<b>33</b>
General.....	33
Front panel controls.....	34
Features .....	35
Local Float/Equalize control .....	35

---

High Voltage Shutdown (HVSD) - local.....	35
High Voltage Shutdown - remote .....	35
Start up delay .....	35
Digital meter VOLT/AMP selection switch .....	36
CUR CAL / V CAL .....	36
Test Points (V+, V-) .....	36
Indicators .....	37
Rectifier Failure Alarm (RFA) .....	37
Fan failure alarm .....	37
Internal High Voltage Shutdown (HVSD) .....	38
Local ON/OFF control (AC breaker) .....	38
Remote ON/OFF control.....	38
Inrush current limiting fuse (F2).....	38
Remote voltage sensing .....	38
Sense fail alarm (SEN FAIL).....	38
Current limiting .....	39
Current limit indicator (CL) .....	39
Soft start / walk-in.....	39
AC inrush current .....	39
Sequential start .....	39
Parallel operation .....	39
Slope load sharing (SLS).....	40
Forced Load Sharing (FS).....	40
Load sharing adjustment .....	40
Discharge of output capacitors .....	41
Input AC voltage monitor (AC ON) .....	41
Thermal shutdown (THSD) .....	41
Remote high voltage shutdown .....	41
Local/Remote high voltage shutdown reset .....	41
Remote equalize control .....	41
Signal connections.....	42
Control and alarm connections .....	42
<b>Maintenance.....</b>	<b>45</b>
General.....	45
Float/Equalize .....	45
High Voltage Shutdown (HVSD).....	46
Cooling Fan .....	46
Fan Failure .....	47
Power shelf.....	50

---



---

<b>Troubleshooting .....</b>	<b>51</b>
------------------------------	-----------

---

<b>Appendix A: Recommended replacement parts .....</b>	<b>55</b>
--	-----------

---

<b>Appendix B: Technical service assistance .....</b>	<b>57</b>
---	-----------

Local toll-free prefixes .....	57
--------------------------------	----

---

<b>List of terms .....</b>	<b>61</b>
----------------------------	-----------

---

**List of Figures**

Figure 1 MPS100 – NT5C12B(X) power shelf .....	13
Figure 2 MPS150 – NT5C12A(X) power shelf .....	14
Figure 3 Switch Mode Rectifier NT5C07 .....	15
Figure 4 AC cabling (direct to power shelves) .....	24
Figure 5 Back panel of MPS150 shelf for 50 A rectifiers .....	25
Figure 6 DC output cabling (direct to power shelves) .....	26
Figure 7 No controller, remote sensing connection .....	28
Figure 8 NT5C07 – Front view .....	34
Figure 9 NT5C07 – Rear view .....	48
Figure 10 NT5C07 – Rear view (chassis plate removed) .....	49

---

**List of Tables**

Table 1 Electrical specifications.....	17
Table 2 Operating specifications.....	18
Table 3 Environmental specifications .....	18
Table 4 Rectifier shelves .....	27
Table 5 Rectifier settings .....	29
Table 6 Setting the start-up delay of the rectifier .....	36
Table 7 Indicators.....	37
Table 8 System’s fault diagnosis .....	51

---

**List of Procedures**

Procedure 1 Removing the blank panel .....	21
Procedure 2 Power shelf installation.....	22
Procedure 3 Standard AC installation (see Figure 4) .....	23
Procedure 4 Rectifier physical mounting .....	29
Procedure 5 Rectifier installation .....	30
Procedure 6 Start up delay .....	31
Procedure 7 Load share adjustment .....	46
Procedure 8 Fan Replacement .....	47

---

This page is left blank intentionally.

---

# Overview

---

## Description

The NT5C07 Switch Mode Rectifier is rated for 50 A at -48 V DC. This rectifier incorporates AC input power factor correction circuitry, is highly efficient and is light weight (22 lbs.). It is fully equipped with connectors and plugs into a power shelf that can house up to three rectifiers. The rectifier is forced air cooled with air entry from the front and exhaust out the rear of the power shelf.

Three separate AC power feeds are connected to the power shelf to provide power to each rectifier through the back plane connectors. The rectifier requires a single phase AC source at a nominal voltage of 208/240 VAC, 50 or 60 Hz, supplied from a single or three phase system between phase to neutral, or phase to phase.

The negative and the positive terminals of the output of each rectifier are connected to two common busses, BAT -48 and BAT RTN +, respectively. The power shelf is designed for a maximum capacity of 150 A. The design of the rectifiers is such that all rectifiers of the same power shelf or other shelves, connected in parallel, share the load, either by the forced load share or by the slope method.

The back plane of the power shelf is equipped with two signal connectors. One is an eight-pin male connector that provides the interface to analog type controllers, and the other is a twenty six pin flat cable (male) type connector for special applications requiring more diagnostics.

Each rectifier provides a variety of monitoring and alarm features such as rectifier failure alarm, fan fail alarm, remote sensing, sense fail alarm, local and remote high voltage shutdown, automatic high voltage shutdown reset, temporary release, remote and local equalize, and shunt remote monitoring.

## Applications

The rectifier is designed to be the prime source of power for equipment requiring -48 V DC. It will also operate as a battery charger or as a battery replacement (batteryless operation). Its low output noise and good voltage regulation, combined with a 0.01% V for each degree C of temperature, provides an excellent charging facility to maintain a battery in a fully charged state.

The NT5C07 rectifier is designed to operate continuously as part of a small or large power system. The NT5C07 rectifier is compatible with all other Astec rectifiers, and can be interfaced with other commercially available standard (compatible) rectifiers and power plants.

## Equipment Identification

This section contains a description of the major components and available options for the NT5C07 Rectifier and the MPS100 and MPS150 power shelves.

Helios Rectifier 50/48:

NT5C07AA	-48V/50A switch mode rectifier, brown
NT5C07AB	-48V/50A switch mode rectifier, oxford grey
NT5C07AC	-48V / 50A switch mode rectifier, dolphin grey
MPS150	NT5C12AA power shelf, 23" mounting brown
	NT5C12AB power shelf, 23" mounting oxford grey
	NT5C12AC power shelf, 23" mounting dolphin grey
MPS100	NT5C12BA power shelf, 19" mounting brown
	NT5C12BB power shelf, 19" mounting dolphin grey

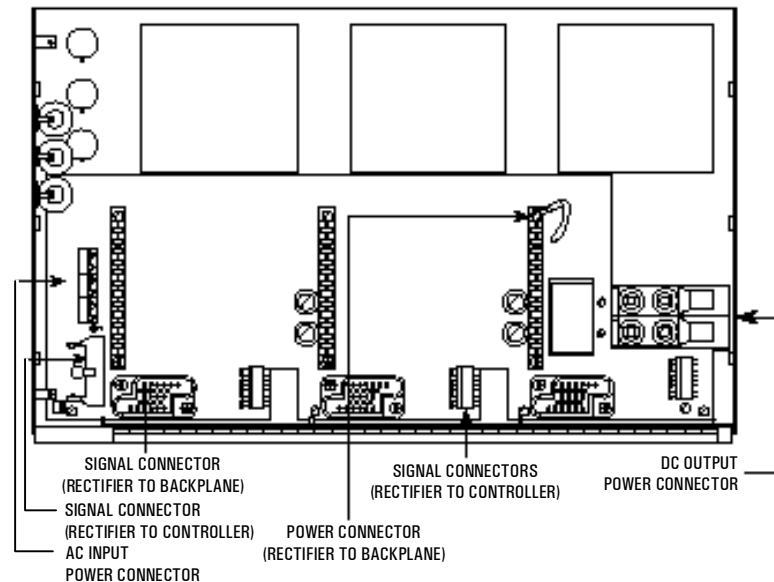
**Figure 1 - MPS100 – NT5C12B(X) power shelf**

Height: 13.0 inches (330 mm)

Depth: 15.0 inches (381 mm)

Width: 17.0 inches (432 mm)

Color: Brown or Grey

Weight: 25 lbs. (11.4 kg)

### **MPS150 - NT5C12A(X) - power shelf (23-inch)**

The MPS150 is a power shelf that can house up to three MPR50 rectifiers. The rectifiers plug into the shelf, and provides interconnection points for AC input, DC output, and alarm and control signals.

Each power shelf requires three AC feeds (one for each rectifier). Its output connects to the charge busbar or to the load distribution panel with two cables (minimum 1/0 AWG), battery and battery return. Each rectifier position has its own connector-equipped alarm and control cable going to the power plant control and monitor unit.

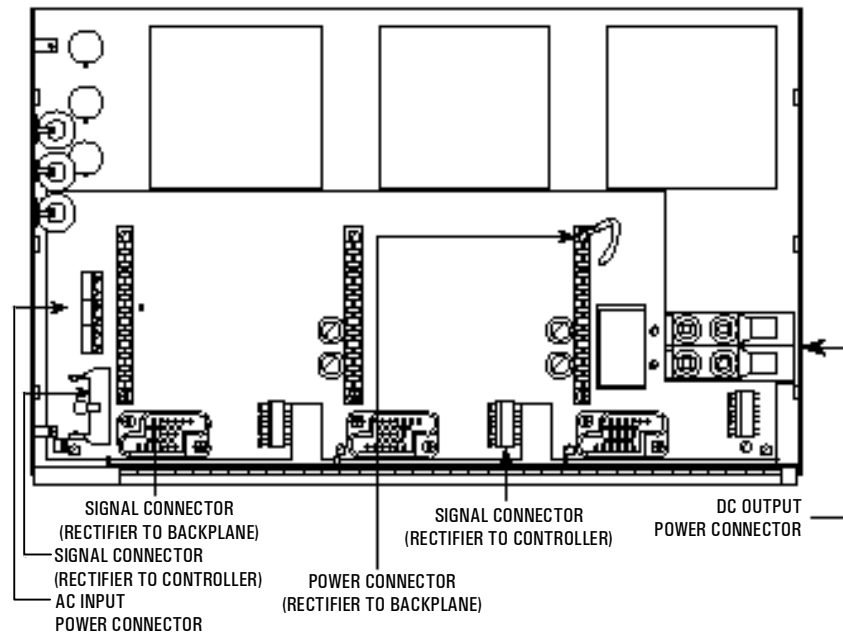
**Figure 2 - MPS150 – NT5C12A(X) power shelf**

Height: 13.0 inches (330 mm)

Depth: 15.0 inches (381 mm)

Width: 21.0 inches (533 mm)

Color: Brown or Grey

Weight: 33 lbs. (15 kg)

### **MPS100 - NT5C12B(X) - power shelf (19-inch)**

The MPS100 is a power shelf that can house up to two MPR50 rectifiers. The rectifiers plug into the shelf, and provides interconnection points for AC input, DC output, and alarm and control signals.

Each power shelf requires two AC feeds (one for each rectifier). Its output connects to the charge busbar or to the load distribution panel with two cables (minimum 2 AWG), battery and battery return. Each rectifier position has its own connector-equipped alarm and control cable going to the power plant control and monitor unit.

Figure 3 - Switch Mode Rectifier NT5C07

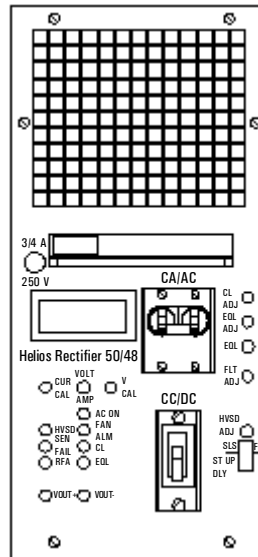

### Helios Rectifier 50/48 NT5C07A(X) -48 V / 50 A Switch Mode Rectifier

The rectifier provides -48 V / 50 A isolated, filtered and regulated DC power from a single phase AC source, for powering a load while charging a positive grounded battery. The output voltage is adjustable over a range of 46.0 to 59.5 V for floating a 23 or 24 cell battery string.

Each rectifier plugs into the MPS100 or MPS150 power shelf and does not require any other connections. The rectifier is equipped with 20 A, two pole, AC input circuit breaker, a 60 A, 1 pole DC output circuit breaker, a digital ammeter / voltmeter and a set of LEDs, switches and potentiometers for threshold adjustments and alarm indication. The rectifier uses high frequency switching technology, is forced air-cooled and can be equipped with an optional air filter.

This page is left blank intentionally.



## Specifications

**Note:** For detailed specifications, please contact your local representative.

The NT5C07 rectifier operates with the electrical specifications provided in Table 1.

**Table 1 - Electrical specifications**

<b>Input Voltage Rating:</b>	Nominal 208/240 V AC single phase. When three phase 208/240 V AC source is available to power the MPS100 or MPS150, it is preferable to distribute the rectifiers among the phases.
<b>Input Current Rating:</b>	15 A nominal at 208 & -56 V DC, 50 A output.
<b>Recommended AC:</b>	Two 20 A fuse (one on each line) or two 20 A circuit breakers (one on each line) for each rectifier.
<b>Service Input Fusing:</b>	Fuse FRN type or equivalent.
<b>Output Voltage Rating:</b>	Float: -46 V DC to -59.5 V DC. Equalize: 0-4 V over float. Maximum -59.5 V DC.
<b>Output Current Rating:</b>	50 A for each rectifier 150 A for NT5C12A(X) power shelves 100 A for NT5C12B(X) power shelves
<b>Input Protection:</b>	Two pole circuit breaker opens both lines for 208/240 V AC service.
<b>Output Protection:</b>	The rectifier contains an adjustable output current limiting circuit for protection against damage from overloads. This circuit is factory set to limit the output current to 52.5 A, however it is adjustable to less than 25 A (50% -105%).  A single pole 60 A circuit breaker is connected in series with the negative output lead in the rectifier.

**Table 2 - Operating specifications**

<b>Efficiency and Power Factor:</b>	Efficiency is better than 88% at the nominal input voltage of 208/240 V AC and an output load greater than 20 A. The power factor is 0.99 at 50 A.
<b>Heat Dissipation:</b>	The maximum heat dissipation is 380 W at -56 V / 50 A or 21.6 BTU's /min.
<b>Electromagnetic Interference (EMI):</b>	The rectifier meets the FCC requirements for conducted and radiated EMI for class "A" equipment.
<b>Safety:</b>	This rectifier is certified to UL-1950, CSA 22.2 and is VDE approved to IEC950. All components used are rated to UL94V-0 for flammability.

**Table 3 - Environmental specifications**

<b>Operating:</b>	An airflow clearance must be left at the rear of the shelf. A minimum of 2 inches is recommended.  The rectifier will operate satisfactorily under the following environmental conditions:  Temperature Range: 0° to +50°C (32° to 122°F) equipped with an air filter 0° to +65°C (32° to 149°F) without an air filter
<b>Transportation:</b>	During transportation the rectifier may be subjected to the following conditions without sustaining damage:  Temperature Range: -55°C (-67°F) for 16 hours +70°C (158°F) dry heat
<b>Storage:</b>	For storage, the acceptable environmental range is:  Temperature Range: -50°C (-58°F) for 16 hours +70°C (158°F) dry heat  The rectifier contains aluminum electrolytic capacitors with a shelf life of 5 years or greater at the maximum rated storage temperature.

---

## Installation and start-up procedures

---

### Installation overview

This chapter contains detailed installation procedures for installing 50 A rectifier NT5C07. The following is a suggested sequence for the installation and start-up procedure. The sequence can be modified according to job and site conditions.

- Obtain the recommended tools and test equipment.
- Read the "Precautions and preparation" section carefully.
- Have all the equipment and material delivered.
- Proceed with the power shelf installation.
- Install and connect the AC input cabling for the rectifiers.
- Install and connect the DC conductors.
- Insert the rectifiers.
- Verify and adjust the rectifiers.

### Tools and test equipment

The following tools and test equipment are recommended:

- Safety goggles
- Screwdriver, flat blade (3/8-inch)
- Screwdriver, flat blade (3/32-inch)
- Screwdriver, Burns No. 60, or equivalent
- Cable strippers / electrician's knife
- Wire stripper
- Cable cutters (2/0)
- Linesman's pliers
- Open and box ended wrenches (set)
- Socket set (1/2-inch drive)
- Ratchet Wrench (1/2-inch drive)
- Torque limiting torque wrench (1/2-inch drive)
- Crimper, T & B 12 or 15 Ton head with 94H die
- Digital Multimeter, Fluke 8000A or equivalent

The power shelf must be installed on the framework and all AC, DC, and control and alarm wiring must be connected before the rectifiers are physically plugged in.

### Precautions and preparation

The following precautions must be followed at all times when installing power equipment:

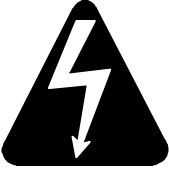
	<p><b>DANGER</b> <b>High current hazard</b></p> <p>The rectifiers, and especially the batteries, can deliver high current should a short to ground occur. When working on live equipment, remove all personal jewelry, use properly insulated tools, and cover any live busbars with a canvas sheet to prevent short circuits caused by falling tools or parts.</p>
---	---

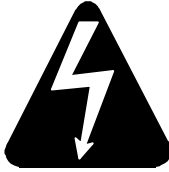
	<p><b>DANGER</b> <b>Preventing electrical shocks</b></p> <p>For safety reasons, the frame ground leads <u>must</u> always be connected before any other leads. This is to prevent the frameworks, and any other metallic structures, from carrying dangerous AC or DC voltage levels.</p>
--	---

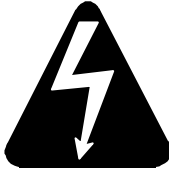
	<p><b>DANGER</b> <b>Preventing electrical shocks</b></p> <p>When wiring the AC input for the rectifiers, ensure that the associated AC breakers, located in the AC service panel, are in the OFF position and that a warning tag clearly indicates that these breakers are to remain OFF until the AC wiring has been completed.</p>
---	--

	<p><b>CAUTION</b>  <b>Preventing damage to electronic circuitry</b></p> <p>The distribution, controller and rectifier modules contain static sensitive circuitry. Precautions against static discharges must be observed at all times. A personal grounding strap is included with the shelf and must be worn at all times when handling the plug-in modules.</p>
---	---

	<p><b>CAUTION</b>  <b>Preventing over-torque damage</b></p> <p>Do not over-torque nuts and bolts. Over-torquing causes the threads to strip, or the bolt to break. Use the appropriate torque values indicated in each section.</p>
---	---

	<p><b>CAUTION</b>  <b>Optimizing equipment life</b></p> <p>To optimize the service life of this equipment, locate it in a dry, well-ventilated area, ensuring there are no obstructions in front of the ventilation openings.</p>
--	---

### Removing the blank panel

The following procedure is recommended for removing a blank panel from the power shelf:

#### Procedure 1 - Removing a blank panel

Step	Action
1	Release the retaining screw.
2	Remove the panel and store it for future use by placing it in the bottom of the shelf, tape side up, with the clinch nut at the rear of the shelf.

-end-

## Power shelf installation

Installation of the power shelf consists of mounting the shelf on a rack and connecting the AC, DC, control and alarm connection cables.

### Procedure 2 - Power shelf installation

Step	Action
1	Position the power shelf, without rectifiers plugged in, against the rack.
2	Fasten the shelf in the position indicated on the job drawing (normally directly below the controller or another shelf). At least one star washer should be installed between the shelf frame and the head of one of the self-tapping screws, to ensure good framework ground continuity.
3	Remove the AC and DC junction box cover and store it for reinstallation.
-end-	

### Power shelf wiring

Once the power shelf is installed and firmly secured proceed with the wiring.



#### **WARNING**

The power shelf wiring should be installed by qualified personnel in accordance with the local electrical code.



#### **DANGER**

#### **Input voltage to the rectifier and the power shelf is at a hazardous potential**

Ensure that the power switch on the AC service panel is at OFF before attempting to work on the power shelf. Hazardous voltages may still be present at the terminals even if the rectifiers are turned OFF. Use a voltmeter to verify the absence of voltage.

	<p><b>DANGER</b>  <b>Improper wiring can cause personal injury and equipment damage</b></p> <p>Verify proper polarity of the battery leads before connecting them to the power shelf, by clearly identifying the positive and negative leads.</p>
---	---

### Procedure 3 - Standard AC installation (see Figure 4)

Step	Action
1	Install the required number and type of circuit breakers at the AC service panel. Refer to the specification chapter of this document for the required breaker ratings.
2	Determine the length of armored cable required to bring the AC from the service panel to the rectifier shelves.
3	Cut the cable to the required length using cable cutters. Run and dress the cable between the AC service panel and the power shelves.
4	Strip the sheathing and insulation material away from the ends of the cable to expose the AC leads.
5	Remove the blank panels at the front of the rectifier shelf. Use a flat blade screwdriver to loosen the retaining bars (the screws are captive).
6	Run the cable into the rectifier shelf through the strain relief connector located at the rear of the shelf. Use a flat blade screwdriver to tighten the strain relief connector around the armored cable (refer to Figure 4).
7	Permanent connection of AC to the MPS100 or MPS150 power shelf at TB1 is done using #12 AWG 2 conductor armored cable, one to L1, one to L2 and the safety ground to the shelf frame ground (FR GND). The cabling must be done in compliance with the local electrical code. The power shelf is equipped with one strain relief for each rectifier position to terminate the conduit. The cable length should be minimized and properly secured. When cabling the AC to the power shelf, make sure that each corresponding safety ground wire is properly connected to the terminal designated FR GND.
—continued—	

**Procedure 3 - Standard AC installation (see Figure 4) ( continued )**

Step	Action
8	Make the power and ground connections inside the shelf. Refer to Figure 5 for connections at the rectifier shelves. This grounding is proven to be sufficient, but for systems requiring an extra ground connection, an 8 AWG green cable wire can be installed in addition to the existing cable and be connected to an external system ground. Using a 0.25-inch ring lug termination, the new ground wire can be installed on one of the existing FR GND terminal screws inside the power shelf. The wire must be run behind the backplane card, near the top and come out on the right DC cabling side opening. Make sure that the wire does not interfere with the rectifier connections.
9	Make the power and ground connections at the AC service panel.
10	Replace the blank panels at the front of the shelves.
—end—	

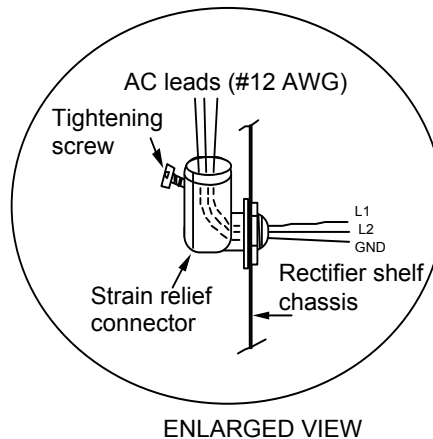
**Figure 4 - AC cabling (direct to power shelves)**

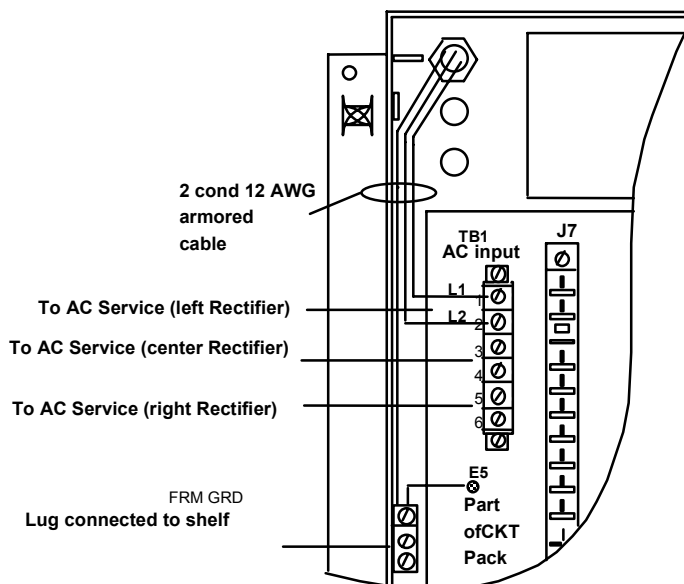

**Figure 5 - Back panel of MPS150 shelf for 50 A rectifiers**

BACK PANEL OF MPS 150 SHELF FOR 50 A RECTIFIERS

**Note:** When the AC service (main) panel contains circuit breakers instead of fuses, a slow trip circuit breaker must be used.

	<p><b>CAUTION</b></p> <p>Do not insert fuses or operate circuit breakers (switches) until the entire system has been assembled and you are instructed to do so in the appropriate procedure.</p>
---	--

### Installing the DC conductors

Make the connections at the power shelf prior to connecting DC leads to the battery or distribution (load). Permanently connect the shelf to the Interconnect and Distribution panel using #2 AWG wire for the MPS100 and #1/0 AWG wire for the MPS150 power shelf. The DC output of the rectifiers is terminated on two busbars (BAT - and BAT RTN +) located on the backplane. Each busbar is equipped with two 0.250 in. diameter studs, 1.000 inch center-to-center spacing. The length of the conductors should be minimized to reduce interference. (Refer to Figure 6).

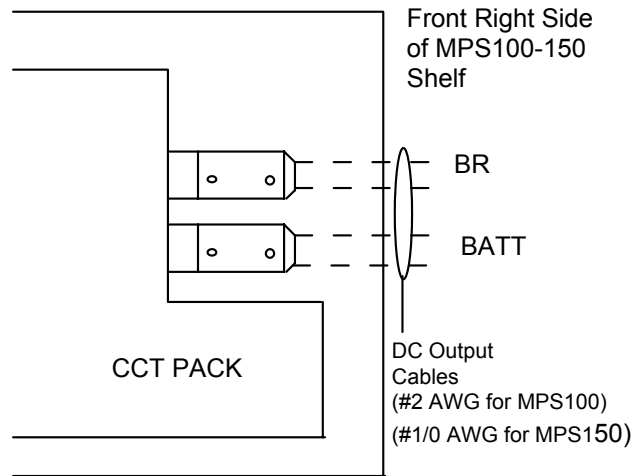
**Figure 6 - DC output cabling (direct to power shelves)**

DC Output Cabling of MPS 100-150

### Control and alarm connections

The rectifier is interfaced to the power plant controller through the signal connectors provided on the back plane of the power shelf. These signal connectors provide control, alarm and monitoring signals.

The power shelf provides two types of signal connectors. One ribbon cable 26-pin male connector or multiple 8-pin male connectors are used to interface the rectifiers to the power plant controller and monitoring unit (see Table 4). The control inputs are activated by a BAT RTN signal. The alarm signals are extended by relay contacts that are isolated from each other and from the chassis. All contacts are rated 60 V DC and 0.5 A. The signal functions are described in the "Control and alarm connections" section in the "Operation" chapter of this manual.

**Table 4 - Rectifier shelves**

MPS150 (3 rectifier shelves)	J14 (26 pins) see Note below	Single cable for all rectifier connections to controller
	J4, J5, J6 (8 pins)	One cable for each rectifier for connection to controller
	J1, J2, J3 (26 pins)	Special applications
MPS 100 (2 rectifier shelves)	J7, J8 (8 pins)	One cable for each rectifier for connection to controller
	J1, J2 (26 pins)	Special applications

**Note:** When using 26-pins ribbon connector J14, the backplane screw E7 must be completely removed.

In applications where force load sharing is desired, all the E6 backplane power shelf terminal screws must be interconnected in a daisy chain fashion with a 20 AWG wire. Position E6 is located at the bottom right of the backplane.

In applications where no controller is available or desired, the current sharing functions among rectifiers in SLOPE or FORCE mode are still available. The signal cable remote sense connections RC- and RG+ must be connected to the desired remote sensing location (batteries). See Figure 7 for a suggested method for connecting the signal wire.

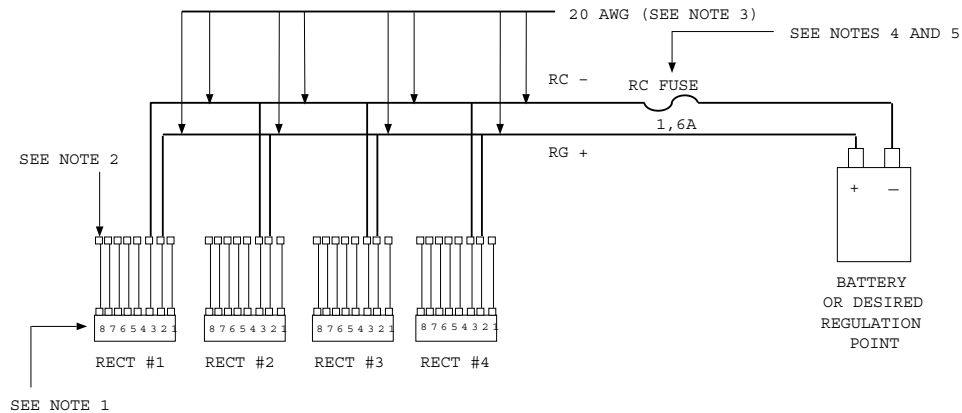
**Figure 7 - No controller, remote sensing connection**

**Note 1:** Refer to MS5C07 for available signal cables of different lengths, to connect from the shelf backplane rectifier position to the remote sensing point.

**Note 2:** Identify the wire color corresponding to the RG+ pin 2 and RC- pin 3 to be used for the remote sensing. Cut the wire near the 8-pin connector and remove it, leaving the signal wires loose. Insulate each unused wire with electrical tape. The wire color may vary with different suppliers. Use the pin references to identify the signals as described above and take note of the corresponding wire color.

**Note 3:** Use 20 AWG wire.

**Note 4:** Use 1.6 A fuse A0384386 with ferrule type fuse holder A0384387.

**Note 5:** Do not install the fuse until the rectifier float adjustment has been completed as described in Procedure 5.

### Verification

After completing the wiring of the power shelf perform the following:

- 1 Verify that the power shelf is mechanically secured.
- 2 Verify that all wiring performed on site is correct by using a voltmeter.
- 3 Verify that all connections are mechanically correct (that is, tight, correct connector and correct marking).

## Rectifier installation

The rectifier is a plug-in unit and is intended for use in the MPS100 or MPS150 power shelf.

### Procedure 4 - Rectifier physical mounting

Step	Action
1	Loosen the captive screws on the rectifier retaining bar and lower the bar.
2	Remove the blank panel from the power shelf and store it in the bottom of the shelf for future use by placing it with the tape side up and with the clinch nut towards the rear of the shelf.
3	Plug the signal and control cable into the controller.
4	Make certain that the two circuit breakers of the rectifier (about to be plugged in) are off (in the down position).
5	Slide the rectifier into the power shelf.
6	Raise the rectifier retaining bar and tighten the shelf captive screw to lock the rectifier in position.
-end-	

## Start-up and verification

If not otherwise specified, the rectifier is factory set as indicated in Table 5.

**Table 5 - Rectifier settings**

Rectifier output voltage (FLOAT)	52.1 V DC	+/- 0.1 V
Rectifier output voltage (EQUALIZE)	52.8 V DC	+/- 0.1 V
Rectifier high voltage shutdown (HVSD)	57.0 V DC	+/- 0.1 V
Rectifier output current limit (CL)	52.5 A	-1 / +2 A
Rectifier delay start (all switches set to off)	4 sec.	+/- 1 sec.
Load Sharing	Slope load sharing method	

**Procedure 5 - Rectifier installation**

<b>Step</b>	<b>Action</b>
<b>1</b>	Open the DC circuit breaker and the sensing leads by removing the corresponding RC fuse from the controller, or by disconnecting the alarm and control cable.
<b>2</b>	Close the AC circuit breaker in the AC service (main) panel.
<b>3</b>	Switch on the AC circuit breaker of the rectifier under test. The green LED designated AC ON should light up.
<b>4</b>	Switch the meter selector switch to the VOLT position. The meter will read the voltage value to which the rectifier has been adjusted.
<b>5</b>	Connect an external meter to test points V- and V+. The voltage reading should be within 1% of the rectifier meter reading.
<b>6</b>	Determine the system requirements for Float, Equalize and HVSD limits referring to User Manual 167-7011-010 <i>Voltage Level Limits for Power Plants, Rectifiers and Controllers</i> .
<b>7</b>	If the rectifier's factory set limits have to be verified or change, proceed as follows, otherwise proceed to step 14.
<b>High Voltage Shutdown Adjustment (HVSD)</b>	
<b>8</b>	With the DC circuit breaker OFF, the HVSD level can be verified or set to a new limit. Turn the FLT potentiometer slowly clockwise until the output voltage reaches the HVSD set point, where the rectifier will shut down.
<b>9</b>	To set the HVSD to a new limit, first turn the HVSD potentiometer fully clockwise. Readjust the Float voltage to the new HVSD limit and then slowly turn the HVSD potentiometer counterclockwise until the rectifier shuts down. Turn the Float potentiometer counterclockwise two turns and reset the rectifier by switching the AC circuit breaker OFF and then ON.
<b>10</b>	Adjust the Float voltage to the correct level.
<b>Float Voltage Adjustment (FLOAT)</b>	
<b>11</b>	Use the FLT potentiometer to increase (clockwise rotation) or decrease (counterclockwise rotation) the float voltage of the rectifier being adjusted.  <b>Note:</b> Preliminary float adjustment should be made with the DC breaker OFF. In the forced load sharing mode, the rectifier float voltage should be the desired float voltage plus 0.8 volt extra to compensate for an internal voltage drop when the DC breaker will be turned ON.  The final float voltage adjustment should be done with the DC breaker ON while supplying the required load.
—continued—	

**Procedure 5 - Rectifier installation ( continued )**

Step	Action
<b>Equalize Voltage Adjustment (EQL)</b>	
12	Set the FLOAT/EQL switch to the EQL position. Turn the EQL potentiometer clockwise to increase the voltage or counterclockwise to decrease it.
13	Set the FLOAT/EQL switch to the FLOAT position.

*Note:* Refer to the load share adjustment procedure for more details on equalize adjustment.

**Load Sharing**

Set the desired load sharing method using the two top switches, labeled SLS/FS, of the dip switch at the lower right hand side of the front plate of the rectifier.

**Current Limit Verification (CL)**

The current limit is factory set to 52.5 A. It cannot be set higher, but by using the CL potentiometer it can be set lower (25 to 52.5 A or 50% to 105%). Verification or adjustment of the CL setting point requires an external load or the office load can be used. Switch OFF or adjust other rectifiers to a lower voltage. This will force the rectifier under test to pick up more load. When the rectifier reaches its current limit point, the yellow LED will light up.

**Start up delay****Procedure 6 - Start-up-delay**

Step	Action
1	Refer to Table 6 in the "Operation" section for the correct start-up delay sequence.
2	Set the start-up-delay for each rectifier so that they will start up sequentially, 8 seconds apart.
3	Verify the start-up delay by shutting down a rectifier and starting it up again. Measure the time from the moment the rectifier is turned on to when it starts delivering current.
-end-	

This page is left blank intentionally.



---

# Operation

---

## General

In addition to rectifying the AC, the input circuit provides EMI filtering, inrush current limiting, low and high AC inhibition, power factor compensation, surge voltage protection and a 20 A AC breaker for input protection.

The output section provides additional EMI filtering and contains a 50 A shunt for output DC current measurement and a 60 A circuit breaker for output protection.

The monitoring circuitry includes; soft start, rectifier fail alarm (RFA), monitoring and control for local and remote equalize, temporary release, thermal shutdown, low and high AC voltage inhibition, local and remote high voltage shutdown (HVSD), local and remote HVSD reset and fan failure detection.

A 3-1/2 digit output current meter displays either the output current or the voltage at the sense point. An internal logic power supply provides all the various voltages required by the logic circuitry and the cooling fan unit.

## Front panel controls

Figure 8 - NT5C07 - Front view

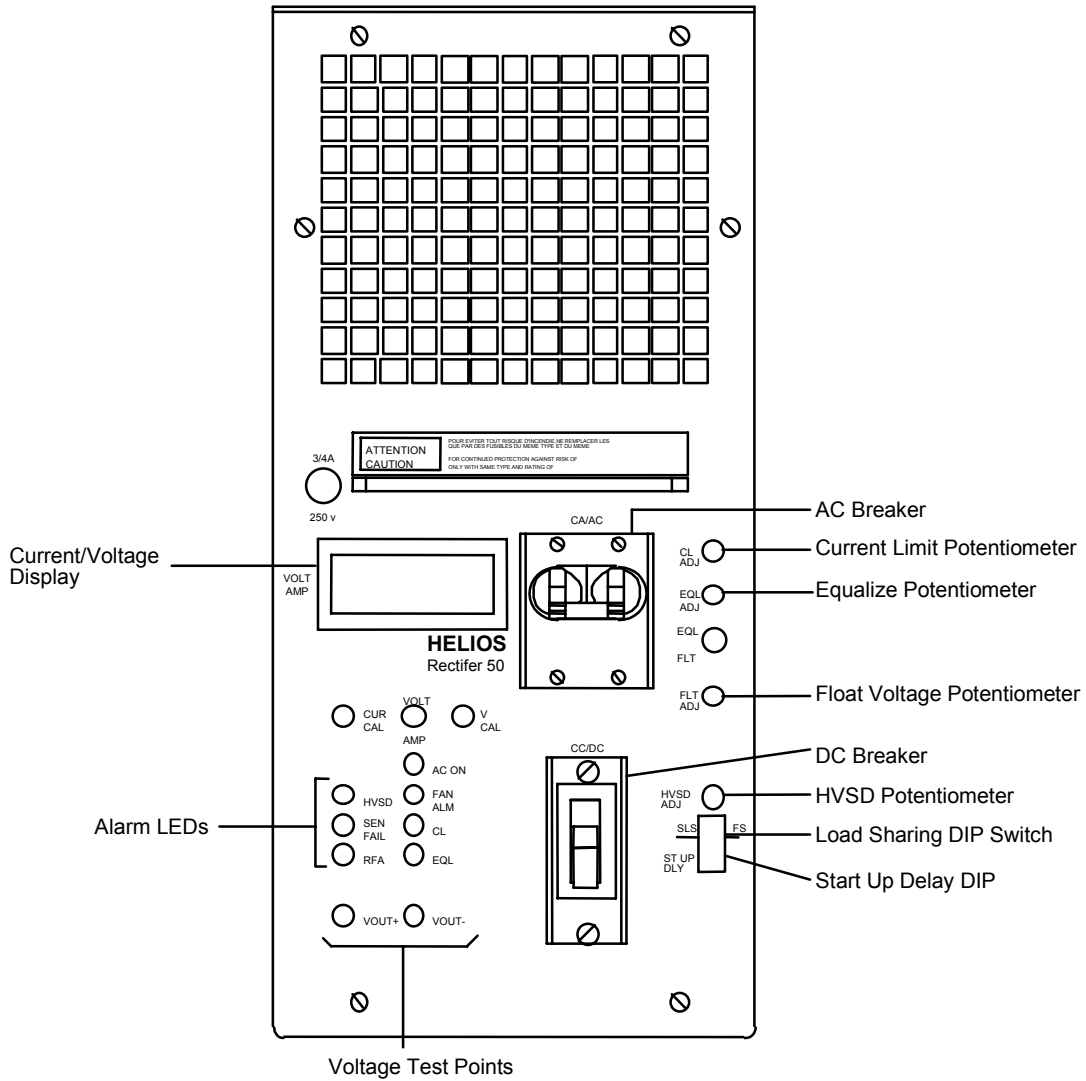

## Features

In addition to the features and performance characteristics described earlier, the rectifier provides the following features.

### **Local Float/Equalize control**

The rectifier is equipped with a float / equalize switch. The rectifier normally delivers a float voltage set by the FLT potentiometer. When the switch is placed in the EQL position, the rectifier changes to equalize mode and boosts the output voltage to the value set by the EQL potentiometer.

### **High Voltage Shutdown (HVSD) - local**

This potentiometer sets the internal threshold level for the local high voltage shutdown monitor circuit.

### **High Voltage Shutdown - remote**

The rectifier can be shut down by an external (remote) HVSD signal from the controller only if it is delivering more than 5 A.

### **Start-up delay**

The unit is capable of providing a start-up delay of up to 120 seconds with a resolution of 8 seconds and an accuracy of  $\pm 4$  seconds. Use of this feature is recommended when multiple rectifiers are connected to a common AC input in order to stagger the start-up current. A front panel dip switch can be set to provide start-up delays according to Table 6. It is recommended that multiple rectifier systems have the rectifiers set to start at 8-second intervals.

**Table 6 - Setting the start-up delay of the rectifier**

Delay (SEC)	Switch 1	Switch 0
4	1	0
12	0	1
20	0	0
28	1	1
36	0	1
44	1	0
52	1	1
60	0	0
68	0	1
76	1	0
84	0	0
92	1	1
100	1	0
108	0	1
116	1	1
124	0	0

**NOTE:**  
These switches correspond to the bottom of four switches on the six-position DIP switch accessible on the front, with contact #1 at the bottom. The shaded areas correspond to switch location.

### Digital meter VOLT/AMP selection switch

This switch determines the measurement mode of the digital display meter. It can select either the output voltage or the output current.

### CUR CAL / V CAL

These pots are used to calibrate the digital display meter for current and voltage measurements. The two potentiometers are not independent of each other. Current calibration must be performed prior to voltage calibration.

### Test Points (V+, V-)

Test points allow the user to measure the voltage at the point of regulation. A 5K resistor is placed in series with both leads to prevent damage caused by short circuits at the jack terminals. The resistors may affect reading accuracy depending on the meter loading. Refer to your meter instruction manual to determine its internal impedance and correction factor, if required.

## Indicators

**Table 7 - Indicators**

LAMP DESIGNATION	COLOR	DESCRIPTION
RFA	RED	RECTIFIER FAIL ALARM
HVSD	RED	HIGH VOLTAGE SHUTDOWN
SEN FAIL	RED	REMOTE SENSE FAIL
AC ON	GREEN	INPUT VOLTAGE VALID
FAN ALM	RED	FAN FAIL ALARM
CL	YELLOW	CURRENT LIMIT
EQL	YELLOW	EQUALIZE

### Rectifier Failure Alarm (RFA)

The rectifier incorporates facilities for monitoring its operational state and extends a global alarm upon detection of an internal failure. An abnormal or out of range AC input voltage, an output fuse failure, any system or internal shutdown (Thermal, HVSD, or TR), or any internal failure causing a disappearance of power switching will trigger the RFA alarm and light up the RFA LED on the front panel. If the disappearance of switching, however, is caused by incorrect adjustment of the output FLT voltage resulting in no output load, the RFA will not be triggered since no real failure occurred.

### Fan failure alarm

Loss of all or part of the cooling system activates the FAN ALM and lights up the appropriate LED on the front panel. An RFA will not be triggered for a single fan failure since the fan configuration has built-in redundancy. When the second fan fails the rectifier will be inhibited and both a FAN ALM and RFA will be generated.

It is, however, imperative that a defective cooling unit be repaired or replaced as soon as possible in order to preserve its redundant characteristic. Before replacing the defective fan, check the fuses located at the back of the rectifier.

### **Internal High Voltage Shutdown (HVSD)**

The rectifier includes a high voltage monitor. Whenever the rectifier output voltage exceeds a preset value adjustable from -52 V to -59.5 V, the rectifier shuts down immediately. The rectifier will attempt to restart itself automatically after an HVSD, however, if another HVSD occurs within approximately two minutes the rectifier will shut down, lock out and transmit an RFA. This function is independent of the output load condition. The AC breaker must be toggled to reset the unit.

### **Local ON/OFF control (AC breaker)**

The input AC circuit breaker can be used locally to turn the rectifier ON/OFF. The local ON/OFF control overrides remote control signals.

### **Remote ON/OFF control**

When a battery return (BAT RTN) signal is applied to the 'Temporary Release' (TR) input, the rectifier inhibits its operation and activates the rectifier's RFA. Upon removal of the remote ground signal the rectifier returns to normal operation.

### **Inrush current limiting fuse (F2)**

A 3/4 A, 250 V fuse is connected in line with the inrush circuitry to protect the input inrush resistor against a prolonged high power dissipation condition in case of an internal failure. Use only the recommended fuse type or equivalent. See "Appendix B: Recommended replacement parts" for specifications.

### **Remote voltage sensing**

Provision is made to extend the sensing leads to the battery or to the charge/discharge bus (batteryless operation) of the plant. Opening either sense lead will not adversely affect the rectifier output voltage and the rectifier will default to internal sensing mode.

### **Sense fail alarm (SEN FAIL)**

In the event that the remote sense leads are not connected, or the sense fuse fails, the SEN FAIL LED on the front panel will light up.

### **Current limiting**

The rectifier will limit the output current to 52.5 A (factory setting). The Current Limit is user adjustable from 25 A to 52.5 A (50% to 105%). Extended periods of operation in the current limiting mode and repeated transitions between constant-voltage operation and constant-current operation, will have no detrimental effect on the rectifier's performance or service life.

The rectifier is capable of starting when connected across a completely discharged battery without requiring human intervention or operating protecting devices. Transitions from constant-voltage operation to constant-current operation, and from constant-current operation to constant-voltage operation, will occur automatically as determined by the output current. The current limit circuit will remain working in both the float and equalize modes.

### **Current limit indicator (CL)**

If the rectifier is in current limit mode, the CL yellow LED lights up on the front panel.

### **Soft start / walk-in**

The rectifier incorporates a walk-in circuit which limits the output current rise to not more than 7 A for each second.

### **AC inrush current**

The AC current during the turn-on sequence of the rectifier, under all input and output conditions specified in this document, will not exceed its full load steady-state value.

### **Sequential start**

The rectifier TR lead is available for use with an external sequential start circuit.

### **Parallel operation**

The rectifier is equipped with two load sharing features that allow it to share the load with one or several rectifiers having similar output characteristics in a power plant. With these features several rectifiers can be paralleled together to build a power plant of any size.

The two load sharing features of the rectifier are referred to as:

- Slope load share (SLS)
- Forced load share (FS)

The load sharing method can be set during installation using the two top switches labeled SLS/FS on the dip switch located at the lower right hand side of the rectifier front panel.

### **Slope load sharing (SLS)**

Slope load sharing is enabled when the two SLS/FS switches are set to the SLS position. This allows the rectifier to decrease its output voltage as its output current goes from no load to full load in order to share the load with other rectifiers in parallel with it. The rectifier output voltage change is internally set at 300mV.

This mode should be selected when the rectifier is used in parallel with other rectifiers not equipped with a forced load sharing feature. In this mode the rectifiers can share the load within 10% of their maximum output rating.

### **Forced Load Sharing (FS)**

Forced load sharing is enabled when the two SLS/FS switches are set to the FS position. This allows the rectifier to adjust its output voltage according to the amount of current it is supplying.

Rectifiers in the same power shelf can be set into the forced load sharing simply by setting the two SLS/FS switches to the FS position.

To set rectifiers from different power shelves into the forced load sharing in a power plant, a jumper cable is required to connect every E6 terminal of each power shelf, in addition to having set the two SLS/FS switches to the FS position.

This mode should be selected when the rectifier is used in parallel with other identical rectifiers. In this mode the rectifiers can share the load within 2% of their maximum output rating.

### **Load sharing adjustment**

The preliminary float voltage adjustment should be made with the DC breaker OFF. In the Forced load sharing mode, the rectifier float voltage should be the desired float voltage plus 0.8 volt extra to compensate for an internal voltage drop when the DC breaker will be turned ON.

Final float voltage adjustment should be made with the DC breaker ON, under the load the rectifier is supposed to deliver. This load is equal to the total load requirement of the central office divided by the number of rectifiers in the power plant.



To adjust the load sharing among the rectifiers in the power plant, use the FLT potentiometer to set the required load on each rectifier.

### **Discharge of output capacitors**

The output capacitors will be completely discharged (<2 V) two minutes after the AC power has been removed and the rectifier has been disconnected from the batteries or parallel units.

### **Input AC voltage monitor (AC ON)**

The rectifier monitors the input voltage and inhibits its operation when the AC voltage decreases below 176 or rises above 264 V AC, and emits an RFA.

The rectifier recovers its normal operation automatically when the input voltage returns within the acceptable limits, without any operator intervention.

### **Thermal shutdown (THSD)**

The rectifier is protected against thermal over stress by inhibiting its operation for the duration of the high temperature condition. The RFA alarm is triggered.

### **Remote high voltage shutdown**

In addition to the local high voltage shutdown feature, the power plant controller can shut down any rectifier by sending a high voltage shutdown signal, ground (BAT RTN) pulse. The rectifier will shut down within 50 ms if it is supplying more than 5 A.

### **Local/Remote high voltage shutdown reset**

The rectifier may be reset from an HVSD condition either locally by toggling the AC circuit breaker or the associated AC breaker on the distribution panel, or by applying a ground signal at the HVSDR input of the rectifier, provided that the 'TR' lead is not activated.

If the HVSD condition subsides the rectifier will restart, but if a second HVSD event occurs within a two-minute interval the rectifier will lock out on the second event and will require manual or remote reset to restart.

### **Remote equalize control**

The rectifier is equipped with remote equalize control. This control is operated by applying a remote ground signal (BAT RTN) and returns to normal (Float) operation upon removal of the signal.

## Signal connections

### Control and alarm connections

The rectifier is interfaced with the power plant controller through the signal connectors provided on the backplane of the power shelf. These signal connectors provide control, alarm and monitoring signals.

The power shelf provides two types of signal connectors. One ribbon cable 26-pin male connector or multiple 8-pin male connectors are used to interface the rectifiers to the power plant controller and monitoring unit (see Table 4). The control inputs are activated by a BAT RTN signal. The alarm signals are extended by relay contacts which are isolated from each other and from the chassis. All contacts are rated 60 V DC and 0.5 A.

- a) Rectifier and controller interface connections (8-pin connector)(see Note below)

Pin #	Desig.	Description	Signal
1	EQL	Remote equalize	BAT RTN
2	RG+	Sensing positiv	BAT RTN
3	RC-	Sensing negative	BAT-
4	FAN ALM	Fan failure	BAT RTN
5	HVSDR	Auto/manual high voltage shutdown reset	BAT RTN
6	HVSD	Remote high voltage shutdown	BAT RTN
7	RFA	Rectifier failure alarm	BAT RTN
8	TR	Temporary release	BAT RTN

**Note:** Both RFA and FAN alarm relays are energized during normal operation and de-energized during an alarm condition.

**Note:** The interface cable is available in 5, 10, 20, 25 and 50 foot lengths.

- b) Rectifier and controller interface connections (26 pins type) for 23 inch, three position shelf NT5C12AA/AB/AC (J14)

<b>Pin #</b>	<b>Designation</b>	<b>Description</b>	<b>Signal</b>
1	RC -	Sensing negative rect (right)	BAT -
2	RFA (NC)	Rectifier (right) fail alarm	NC
3	TR	Temporary release rect (right)	BAT RTN
4	SH +	Shunt positive rect (right)	50 MV
5	SH -	Shunt negative rect. (right)	50 MV
6	RC -	Sensing negative rect (right)	BAT -
7	RFA (NC)	Rectifier (center) fail alarm	NC
8	TR	Temporary release rect (center)	BAT RTN
9	SH +	Shunt positive rect (center)	50 MV
10	SH -	Shunt negative rect (center)	50 MV
11	RC	Sensing negative rect (left)	BAT -
12	RFA (NC)	Rectifier (left) fail alarm	NC
13	TR	Temporary release rect (left)	BAT RTN
14	SH +	Shunt positive rect (left)	50 MV
15	SH -	Shunt negative rect (left)	50 MV
16	CUR SHARE	Current share	0 - 12 V DC
17	RFA (C)	Rectifier fail alarm	Common
18	ALM COMMON	Alarms common	Common
19	EQL	Remote equalize	BAT RTN
20	RG +	Sensing positive	BAT RTN
21	HVSDR	Remote high voltage shutdown reset	BAT RTN
22	HVSD	Remote high voltage shutdown	BAT RTN
23	DC BRK ALM	DC circuit breaker	NC
24	AC FAIL ALM	AC line fail alm	NC
25	SENSE FAIL ALM	Sense fail	NC
26	FAN ALM	Fan alarm	NC

**Note:** The (NC) normally closed annotation signifies that the alarm is sent when contact between the alarm (NC) and alarm common is closed (shorted). All the alarm commons are floating. Connect pin 17 and 18 to the system battery return, if the alarm commons need to be referenced to the bat (+) battery return.

- c) Rectifier and Controller Interface Connections (26-pin connector) for 19 inch two position shelf NT5C12BA/BB (J1,J2)

PIN #	DESIG.	DESCRIPTION	SIGNAL
1	EQL	Remote equalize	BAT RTN
2	RG+	Sensing positive	BAT RTN
3	RC-	Sensing negative	BAT-
4	TR	Temporary release	BAT RTN
5	HVSDR	Remote high voltage shut down reset	BAT RTN
6	HVSD	Remote high voltage shutdown	BAT RTN
7	RFA	Rectifier fail alarm	NC
8	CS	current share	0-12 VDC
9	FAN ALM	fan alarm	NC
10	RFA	rectifier fail alarm	COMMON
11	FAN ALM	fan alarm	COMMON
12	SH+	shunt positive	50mV
13	SH-	shunt negative	50mV
14	FAN ALM	fan alarm	NC
15	RFA	rectifier fail alarm	NO
16	BAT RTN	battery return	BAT RTN
17	SEN FAIL	sense fail	COMMON
18	SEN FAIL	sense fail	NC
19	SEN FAIL	sense fail	NO
20	DC BRKR	dc circuit breaker	COMMON
21	DC BRKR	dc circuit breaker	NC
22	PRESENT 1	rectifier plugged in	
23	PRESENT 2	rectifier plugged in	

**Note:** Both RFA and FAN alarm relays are energized during normal operation and de-energized during an alarm condition.

---

# Maintenance

---

## General

	<p><b>CAUTION</b> <b>Preventing further damage to the equipment</b></p> <p>Do not attempt any other repair than those listed below. If any problem persists, contact our nearest Customer Service Department (refer to “Appendix C: Technical service assistance”).</p>
---	---

The NT5C07 rectifier is virtually maintenance free. It requires periodic float/equalize verification (once every six months) and air filter replacement as required.

**Note:** If the unit operates in a dusty environment the optional air filter is recommended. It must be inspected and changed or thoroughly cleaned at least every 12 months, or sooner if the dust level is high.

	<p><b>CAUTION</b> <b>Do not install a wet filter on the unit</b></p> <p>To remove the filter, simply unscrew it. Re-install by reversing the operation.</p>
---	---

## Float/Equalize

The float/equalize voltage level of the rectifier can be verified or adjusted with the rectifier in or out of service. When it is preferred to verify the equalize setting point with the rectifier out of service, proceed as follows.

**Procedure 7 - Load share adjustment**

Step	Action
1	Remove the corresponding rectifier sense fuse from the controller.
2	Open the DC circuit breaker.
3	Switch the FLT/EQL switch to the EQL position.
4	If the voltage requires readjustment use the EQL potentiometer to set the equalize voltage to the new level.
5	Reinsert the sensing fuse and close the DC circuit breaker.
6	The float voltage should be adjusted with the rectifier in service following the load share adjustment procedure. The rectifier is connected to the system and should carry some load. If the rectifier is connected in parallel with other rectifiers, verify that the total system load current is shared equally amongst the rectifiers. If the current reading is too low or nil, slowly turn the FLT potentiometer clockwise until sharing is achieved. If the current reading is too high or the unit is in the current limit mode, turn the FLT potentiometer counterclockwise.
-end-	

**High Voltage Shutdown (HVSD)**

To verify or readjust the HVSD follow steps 8 to 10 of Procedure 5 in the "Installation and start-up procedures" chapter of this manual.

**Cooling Fan**

Visually inspect the airflow intake for any obstruction by foreign objects or excessive dust and dirt build-up. Open both the AC and DC breakers and remove the rectifier from the power shelf. Inspect the air outlet for obstruction by foreign objects or excessive dust and dirt build-up. Visually inspect the air outlet of the enclosure or cabinet. If a problem is detected in the rectifier, contact your local Astec service facility. The unit is not designed for on-site servicing.

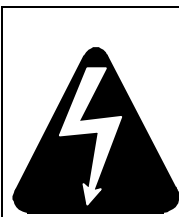
**DANGER**

Do not attempt to reach inside the unit with any tool or fingers; severe electrical shock could result.

### Fan failure

If a fan alarm persists after cleaning the fan filter and removing the dust particles from inside the unit and fan assembly, replace the fan assembly as follows:

	<p><b>CAUTION</b></p> <p>Before replacing the fan, turn the rectifier <b>OFF</b>. Completely disconnect and remove it from the shelf. Wait 30 minutes to allow all internal capacitors to fully discharge and for all components to cool down.</p>
---	--

### Procedure 8 - Fan replacement

Step	Action
1	With the unit solidly set on a clean workbench, carefully remove the four mounting screws which hold the fan assembly. (Refer to Figure 9.)
2	Slowly and carefully remove the fan assembly by pulling it from the chassis.
—end—	

	<p><b>CAUTION</b></p> <p>Take the necessary precautions to prevent dirt, dust, moisture or metallic particles from entering the unit.</p>
---	---

**Figure 9 - NT5C07 - Rear view**

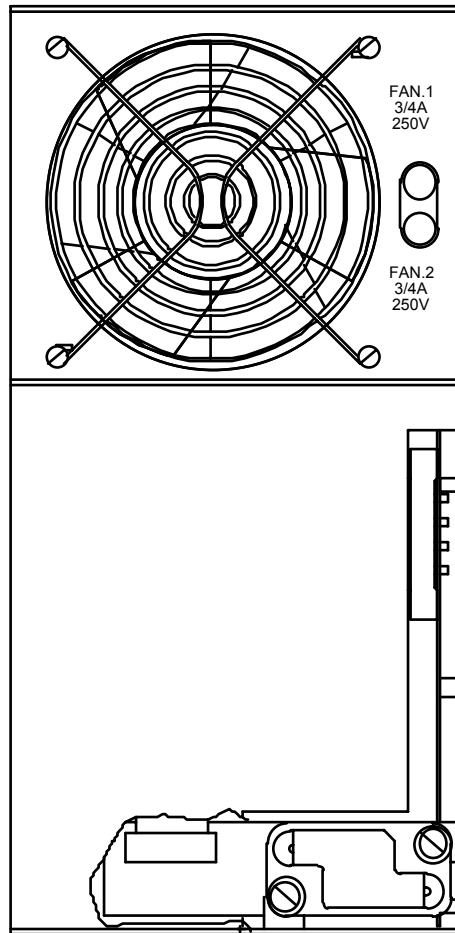

- Disconnect the two 3-pin connectors.
- Take note of which side the wire is connected to the fans.
- Remove the four retaining screws which hold the chassis plate, the fans and fan grill together. (Refer to Figure. 9.)

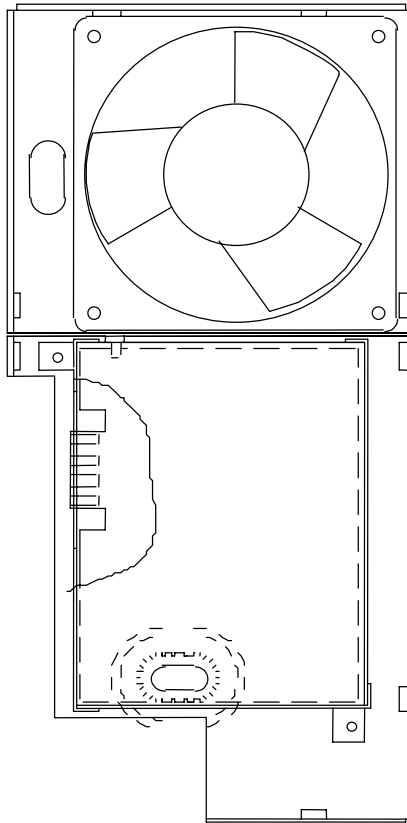

**Figure 10 - NT5C07 - Rear view - (chassis plate removed)**

- Replace the failed fan with a new one.
- Place the mounting clips on the replacement fan if it is not so equipped.
- Mount the fan assembly in the same orientation as the old one, ensuring the wire is connected to the fans in the same manner. Ensure the orientation of the fans is such that the air is blown outwards when the fans are operated.
- Secure the fans, fan grill and chassis plate with the four retaining screws.
- Reconnect the fan connectors and mount the fan assembly in the unit with the four mounting screws.

	<p><b>CAUTION</b></p> <p>Ensure that the fans spin freely without interference.</p>
---	---

- Plug the unit back in and power it up. Holding a piece of paper at the front of the unit should confirm that the air is pulled inwards from the front.
- Listen carefully to detect any noise from the fans. They should run freely. Verify that the fan alarm is off.

	<p><b>CAUTION</b></p> <p>Do not run the rectifier without a fully operational fan or a fan other than the one specifically selected as a replacement for this cooling application.</p>
---	--

### **Power shelf**

The power shelf is free of maintenance requirements.

## Troubleshooting

**Table 8 - System's fault diagnosis**

<b>Fault symptom</b>	<b>Possible causes</b>
<b>RFA</b>	No AC input or input out of bounds (AC ON LED is off).
	AC Input/DC output circuit breaker is open.
	Rectifier has received a HVSD signal from the controller or a TR signal is present.
	An internal high voltage shutdown (HVSD) has occurred.
	Both cooling fans and/or fuses have failed.
	Inrush fuse has blown.
	DC circuit breaker is open.
	A thermal shutdown has occurred.
	Excessive ambient air temperature.
	Inlet/outlet air blocked, clogged air filter.
	Unit is in 'Start Time Delay' mode and RFA will cease when required time delay has elapsed.
	Defective unit.
<b>HVSD</b>	Internal high voltage shutdown point set to low (below float and / or equalize setting).
	Excessive impedance in one or both sense leads.
	DC circuit breaker is open but unit is in remote sense.
	A remote HVSD was issued from the controller.
<b>AC ON LED is off</b>	No AC input voltage.
	Input circuit breaker is open.
	AC voltage is present but is out of operational limits. Unit will restart when the AC returns within bounds.
–continued–	

**Table 8 - System's fault diagnosis ( continued )**

<b>Fault symptom</b>	<b>Possible causes</b>
<b>AC ON LED is off</b>	AC has just been applied and the unit will start momentarily (after inrush control delay.)
<b>FAN ALM</b>	One or both fan fuses have failed.
	One or both fans have failed.
—continued—	

**Note 1:** For a single fan or fan fuse failure the rectifier will continue to operate while issuing a local and remote FAN ALM alarm.

**Note 2:** If both fans and/or fan fuses have failed the unit will shut down and issue local and remote RFA alarms.

<b>Fault symptom</b>	<b>Possible causes</b>
<b>SEN FAIL</b>	One or both remote sense leads is disconnected.
<b>CL</b>	Output load requirement exceeds total rectifier capacity.
	With paralleled units, the float or equalize is maladjusted causing one or more units to carry the load.
	Unit is in "equalize" mode and paralleled units are not.
	Remote sense lead has excessive impedance on one or more rectifiers.
	System batteries are in recharge mode after AC outage.
	Current share mode selection is not the same for all units.
Forced share line is disconnected (in FLS only).	
—end—	

---

## Appendix A: Recommended replacement parts

---

The following replacement parts are recommended for the Helios Rectifier 50/48:

<b><u>ITEM</u></b>	<b><u>CPC</u></b>
Fan Assembly	P0734037
Fuse MDA-0.750 A / 250 V	A0351850
Air Filter Kit	P0736368
Replacement Filter	P0734555
Fuse 1.6 A / 250V	A0384386

This page is left blank intentionally.

---

## Appendix B: Technical service assistance

---

For technical assistance, 24-hours a day / 7 days a week, dial one of the following toll-free numbers. This service complements the services offered by field support organizations such as, the Emergency Technical Assistance Service (ETAS), and the Installation Technical Assistance Service (ITAS).

### Local toll-free prefixes

The following prefixes give access to toll-free numbers in various countries. For further information please contact the local service provider.

Country	Prefix
Australia	0011
Belgium	00
Brazil	0021
Denmark	00
Finland	00 or 990
France	00
Germany	00
Hong Kong	001
Ireland	00
Japan	001 (KDD) 041 (ITJ) 0061 (IDC)
Korea	001 (Korea Telecom) 002 (Dacom) 003 (Once)
Malaysia	00
Netherlands	00
New Zealand	00
Singapore	001
Switzerland	00
United Kingdom	00

**Toll-free technical assistance numbers**

<b>United States:</b>	1-800-992-8417	<b>Canada:</b>	1-800-363-2288
<b>In Europe:</b>		<b>In Asia and the Pacific:</b>	
Austria	800-213-49156	Australia	800-213-49156
Belgium	800-213-49156	Hong Kong	800-213-49156
Denmark	800-213-49156	Japan	800-213-49156
Finland	800-213-49156	Malaysia	800-213-49156
France	800-213-49156	New Zealand	800-213-49156
Germany	800-213-49156	Philippines	1-800-1-110-0131
Ireland	800-213-49156	Singapore	800-213-49156
Italy	800-213-49156	South Korea	800-213-49156
Netherlands	800-213-49156	Taiwan	800-213-49156
Norway	800-213-49156		
Sweden	800-213-49156		
Switzerland	800-213-49156		
United Kingdom <sup>*1</sup>	800-213-49156		
<b>In the Caribbean and Latin America (CALA):</b>		<b>In the Middle-East:</b>	
Bahamas	1-800-389-0081	Israel	800-213-49156
Barbados	1-800-534-0225		
Brazil	08-1571-012288		
Colombia	980-192288		
Dominican Republic	1-888-7514232		
Jamaica	1-800-850-1755		
Mexico	001-800-514-2288		
Puerto Rico	1-888-680-2288		
Trinidad & Tobago	1-800-363-2288		

<sup>\*1</sup> The United Kingdom includes England, Guernsey, the Isle of Man, Jersey, Northern Ireland, and Scotland.

For countries not covered by a toll-free service dial Canada (country code 001) at 514-832-6707.



---

## List of terms and acronyms

---

<b>ALM</b>	Alarm
<b>BAT RTN</b>	Battery Return
<b>C</b>	Common
<b>CS</b>	Current Share
<b>EMI</b>	Electromagnetic Interference
<b>EQL</b>	Equalize
<b>FAN ALM</b>	Fan Alarm
<b>FS</b>	Forced Load Share
<b>HVSD</b>	High Voltage Shutdown
<b>HVSDR</b>	High Voltage Shutdown Reset
<b>LED</b>	Light Emitting Diode
<b>LVA</b>	Low Voltage Alarm
<b>LVD</b>	Low Voltage Disconnect
<b>LVDR</b>	Low Voltage Disconnect/Reconnect
<b>MPL</b>	Modular Power Low Voltage Disconnect
<b>MPR</b>	Modular Power Rectifier
<b>MPS</b>	Modular Power Shelf
<b>NC</b>	Normally Closed
<b>NO</b>	Normally Open
<b>PCB</b>	Printed Circuit Board
<b>RFA</b>	Rectifier Fail Alarm
<b>RG+</b>	Sensing Battery Positive
<b>RG-</b>	Sensing Battery Negative
<b>SLS</b>	Slope Load Sharing
<b>TR</b>	Temporary Release

This page is left blank intentionally.



# **Helios Rectifier 50/48 Single Phase —48 V, 50 A Switch Mode Rectifier NT5C07 Installation and User Manual**

Astec Advanced Power Systems Ltd  
2280 Alfred-Nobel Blvd  
St.Laurent ( Quebec ) Canada  
H4S-2A4

Copyright © 2001 Astec Advanced Power Systems Ltd  
All Rights Reserved

The information contained in this manual is the property of Astec Advanced Power Systems and is subject to change without notice. Astec Advanced Power Systems Ltd reserves the right to make changes in design or components as progress in engineering and manufacturing may warrant. Except as specifically authorized in writing by the V.P. of Engineering and Product Manufacturing of Astec Advanced Power Systems Ltd, the holder of this manual shall keep all information contained herein confidential and shall protect same, in whole or in part, from disclosure and dissemination to all third parties, and use the same for start-up, operation, troubleshooting, and maintenance purposes only. Any modification to the equipment must be approved by the person responsible for product safety, and design quality at Astec Advanced Power Systems Ltd to ensure that the equipment complies with the operation standards.

This equipment generates, uses, and can radiate radio frequency energy, and if not installed and used in accordance with the instructions contained in the Installation and User Manuals, can cause harmful interference to radio communications. Operation of this equipment in a residential area is likely to cause harmful interference, in which case the user will be required to correct the interference at his own expense.

Astec Advanced Power Systems  
*A part of Emerson Network Power*

Helios Candeo is a trademark of Astec International Ltd. The Emerson logo is a trademark and service mark of Emerson Electric Co.

Manual Number : UM5C07 ( 169-2071-501 )  
Manual Issue : 12.00  
Manual Status : Standard  
Release Date : May 2001  
P0734780

Published in Canada

