Meridian 1

Power engineering

Document Number: 553-3001-152

Document Release: Preliminary 11.02

Date: June 2002

Copyright © 1990–2002 Nortel Networks
All Rights Reserved

Printed in Canada

Information is subject to change without notice. Nortel Networks reserves the right to make changes in design or components as progress in engineering and manufacturing may warrant. This equipment has been tested and found to comply with the limits for a Class A digital device pursuant to Part 15 of the FCC rules, and the radio interference regulations of Industry Canada. These limits are designed to provide reasonable protection against harmful interference when the equipment is operated in a commercial environment. This equipment generates, uses and can radiate radio frequency energy, and if not installed and used in accordance with the instruction manual, may cause harmful interference to radio communications. Operation of this equipment in a residential area is likely to cause harmful interference in which case the user will be required to correct the interference at their own expense.

SL-1 and Meridian 1 are trademarks of Nortel Networks.

Revision history

June 2002

Preliminary 11.02. This document has been upissued to include new material provided from verification and validation of product.

January 2002

Standard 11.00. This document is up-issued for Release 25.40 and includes information on the NT4N49 DC Power Distribution Unit.

April 2000

Standard 10.00. This is a global document and is up-issued for X11 Release 25.0x. Document changes include removal of: redundant content; references to equipment types except Options 11C, 51C, 61C, and 81C; and references to previous software releases.

October 1997

Standard, release 9.00. Changes are noted by revision bars in the margins.

December 1995

Standard, release 8.00. This document is reissued to include information on the System 600/48 Power Plant.

July 1995

Standard, release 7.00. This document is reissued to include international information to create a global NTP and update information pertaining to Meridian 1 option 81C. Changes are indicated with change bars in the margins.

December 1994

Standard, release 6.0. This document is reissued to update information pertaining to Meridian 1 option 51C. Changes are indicated with change bars in the margins.

April 1994

Standard, release 5.0. This document is reissued to update and expand information on Meridian 1 power systems, and to include information pertaining to Meridian 1 option 61C and the information on NT0R72 Rectifier as a replacement for the older NT6D52 Rectifiers in an existing NT7D12 Rectifier Rack Assembly. Changes are indicated with change bars.

August 1993

Standard, release 4.0. This document is reissued to update and expand information on Meridian 1 power systems, and to include information pertaining to system option 21E, option 81, and the NT7D67CB PDU used in DC systems.

December 1991

Standard, release 3.0 (release to CD-ROM only).

October 1990

Standard, release 2.0

January 1990

Standard, release 1.0

Contents

About this document	9
Contents	9
Reference list	9
Introduction	10
Notation conventions	10
Meridian 1 power systems	11
Contents	11
Reference list	12
Introduction	12
AC power	13
DC power	14
Grounding	16
Single Point Grounding	16
Types of ground	19
Identifying good grounds	24
Circuit protection	25
Power service panel	25
AC power systems	26
AC power input specifications	26
AC internal power distribution	27
DC power systems	32
Input power specifications	33
Internal power distribution	33
External power distribution	38

Reserve power	42
AC reserve power	42
DC reserve power	47
Meridian 1 power plants	51
Contents	51
Reference list	51
Introduction	51
MFA150 Modular Power System	52
MPP600 Modular Power Plant	57
System 600/48	60
J2412 Power Plant	67
NT6D82 Power System	73
Component power consumption	85
Contents	85
Reference list	85
Introduction	85
Power calculation guidelines	89
Meridian 1 upgrades	92
Powering upgraded systems from existing rectifiers	92
Selecting proper wire size	97
Contents	97
Introduction	97
Typical wire values	98
Metric conversion	100
Sense lead wire size	100
Calculating wire size	101
Input wire size	102
NT4N49 DC Power Distribution Unit Installation .	105
Contents	105

Overview	105
NT4N49 DC power	106
NT4N49 DC PDU preparation	108
NT4N49 DC PDU installation	109
PDU connections	110
Power connection from power plant to NT4N49 DC PDU	115
Connecting Meridian Power DC to the NT4N49 DC PDU	120
DC Power Distribution Unit Replacement	123
Contents	123
Introduction	123
Replacement preparation procedures	123
Index	131

About this document

Contents

This section contains information on the following topics:

Reference list	9
Introduction	10
Notation conventions	10

Reference list

The following are the references in this section:

- *NT6D82 Power System: Description, Installation, and Maintenance* (553-3001-110)
- *Option 11C and 11C Mini Technical Reference Guide* (553-3011-100).
- *Library Navigator* (553-3001-000)
- *System Overview* (553-3001-100)
- *Installation Planning* (553-3001-120)
- *Equipment Identification* (553-3001-154)
- *System Installation Procedures* (553-3001-210)
- *General Maintenance Information* (553-3001-500)
- *Hardware Upgrade Procedures* (553-3001-258)

This document is a global document. Contact your system supplier or your Nortel Networks representative to verify that the hardware and software described is supported in your area.

Introduction

This document describes Meridian 1 AC-powered systems, DC-powered systems, and reserve power options for both. It also gives operating power requirements, including guidelines for calculating system power consumption, and provides guidelines for determining wire size for power connections.

See *Installation Planning* (553-3001-120) for information on system grounding, the commercial power source, auxiliary power, and the power fail transfer unit (PFTU). See *General Maintenance Information* (553-3001-500) for information on system monitor capabilities.

Notation conventions

In North America, there are a number of branch circuit wiring methods recognized by the U.S. National Electrical Code (NEC) and the Canadian Electrical Code (CEC). Among them are:

- 208/120 V, three-phase, four-wire, “wye” service
- 240/120 V, three-phase, four-wire, “delta” service
- 240/120 V, single-phase, three-wire service

Sometimes nomenclature is confusing. For example, the third method (240/120 V, single-phase, three-wire, service) is often referred to as 220/110, 230/115, 240/120, or 250/125 V. This is because, as a result of voltage drops, the nominal voltage varies from region to region, utility to utility, and even within the same distribution network. In addition, the ratings of the plugs and receptacles used are 250 and 125 V, although the nominal voltages are usually lower than this.

As a convention throughout Meridian 1 documentation, the term 208/240 V is used as the nominal input voltage, and 120 V is used to refer to the nominal voltage of any associated auxiliary power circuits.

Meridian 1 power systems

Contents

This section contains information on the following topics:

Introduction	12
Reference list	12
AC power	13
DC power	14
Grounding	16
Single Point Grounding	16
Types of ground	19
Identifying good grounds	24
Circuit protection	25
Power service panel	25
AC power systems	26
AC power input specifications	26
AC internal power distribution	27
DC power systems	32
Input power specifications	33
Internal power distribution	33
External power distribution	38
Reserve power	42
AC reserve power	42
DC reserve power	47

Reference list

The following are the references in this section:

- *System Installation Procedures (553-3001-210)*
- “Selecting proper wire size” on page 97
- “Component power consumption” on page 85
- “Powering upgraded systems from existing rectifiers” on page 92

Introduction

Meridian 1 features a modular power distribution architecture. As part of the modular design, the Meridian 1 power system provides:

- A power distribution unit located in the pedestal which functions as a distribution point for the input voltage (AC or DC) to each module and protects them from current overload
- Power supplies located in each module, rather than in separate centralized power shelves
- A universal quick-connect power wiring harness, which carries the power and monitor signals to the power supplies in each module
- Modular backup capabilities on a per column basis

The terms “AC system” and “DC system” refer to the type of power brought into the pedestal and distributed within the system to the module power supplies. Figures 1, 2, and 3 show the basic power distribution for AC and DC systems. All Meridian 1 Core system options (except option 21A) are available in both AC power and DC power versions. Option 21A is available with AC power only.

To understand the Meridian 1 power architecture, consider the distinction between the “internal” and “external” power components. Internal power components are those contained within the Meridian 1 itself that form an integral part of the Meridian 1 power subsystem. These include components such as the power distribution unit (PDU) in the pedestal, the power wiring harness, and the module power supplies.

Although the PDU and module power supplies differ in AC- and DC-powered systems, power distribution is similar: power is input to the pedestal and distributed to individual power supplies in each module. In AC-powered systems, the module power supplies convert the AC voltage to several usable DC voltages; in DC-powered systems, the module power supplies convert the DC voltage to several usable DC voltages. Except for the power components and the power wiring harness, all other functional elements within the system (such as card cages, backplanes, circuit cards, and system monitor) are identical in both AC and DC systems.

External power components are those outside the Meridian 1 columns. If reserve power is not required, AC-powered systems have no external components; AC systems plug directly into the commercial AC power source. If an uninterruptible power supply (UPS) is installed for reserve power, it is considered an external power component. All DC systems are powered by rectifiers that are external to the system.

AC power

AC-powered systems require no external power components and can plug directly into the commercial utility power source (see Figure 1). AC powering requires a single conversion from the AC input voltage to the DC voltages required by the system. This conversion is performed by power supplies in each module.

AC-powered systems are well-suited for applications that do not require reserve power. They are also recommended for small-to-medium-sized (two columns or less) systems that require reserve power with backup times ranging from 15 minutes to 8 hours.

If reserve power is required with an AC-powered system, an uninterruptible power supply (UPS) is installed in series with the AC power source (see Figure 2). AC-powered systems that do not require long-term backup can benefit from a UPS with short-term backup. A UPS can provide power conditioning during normal operation, including protection against sags, brownouts, and other low-voltage transient conditions that cause most power disturbances.

Figure 1
AC-powered system

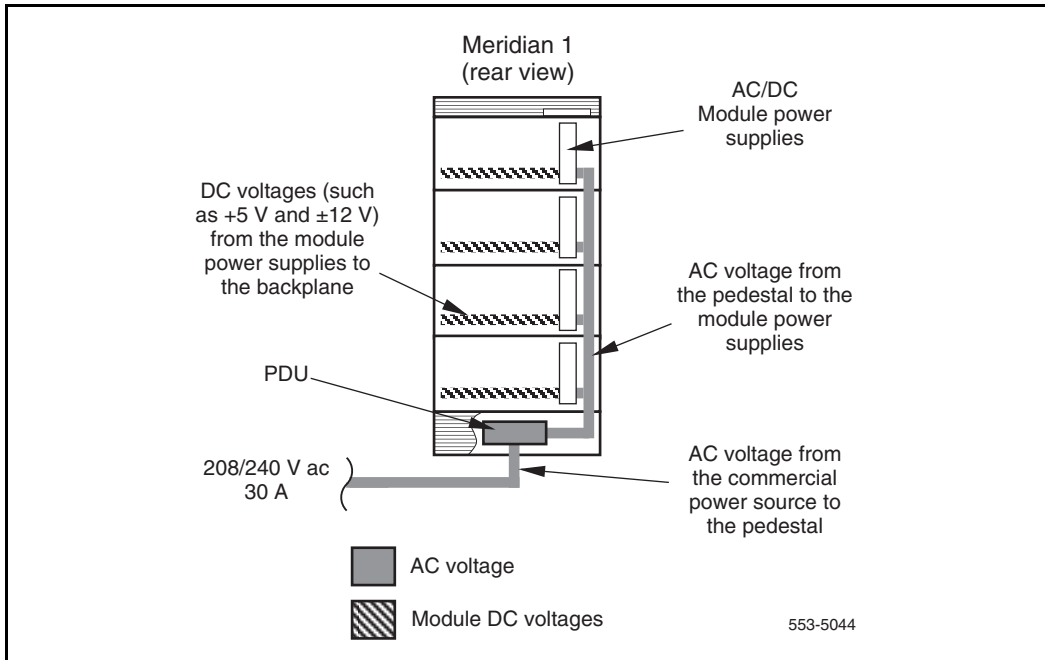

DC power

DC-powered systems require external rectifiers which connect directly to a commercial AC power source (see Figure 3). DC-powered systems require a double conversion: the rectifiers convert the AC voltage to -48 V dc which is distributed by the PDU in the pedestal to the power supplies in the modules. The power supplies convert -48 V dc to other DC voltages required in each module.

Batteries are generally used with DC-powered systems because the traditional method for powering telecommunications uses rectifiers to continuously charge a bank of batteries, while the system power “floats” in parallel with the battery voltage. However, batteries are only used if reserve power is needed. Figure 4 shows a DC system with reserve power equipment.

Figure 2
AC-powered system with reserve power

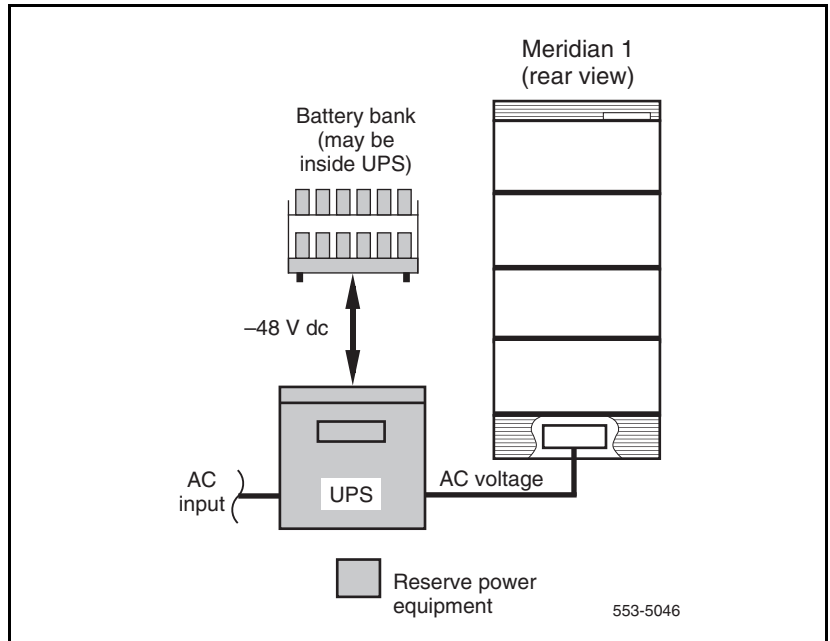

Complete systems—including DC power plants—can be provided by Nortel Networks. Systems can also be configured to connect to an existing power plant provided by the customer.

DC systems should be considered for the following:

- Most large systems (81C or any system larger than two columns)
- Most systems with long-term reserve power requirements (usually eight hours or more)
- When the customer site has an existing DC power plant or batteries available

Figure 3
DC-powered system

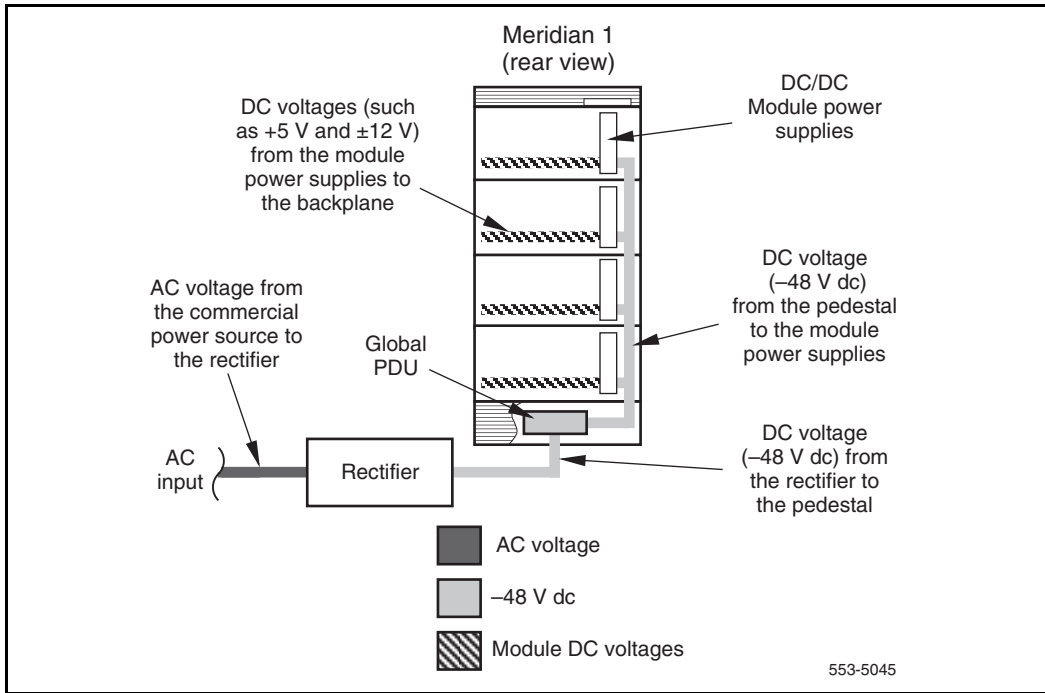

Grounding

Proper grounding is essential for trouble-free system operation and the safety of personnel.

Single Point Grounding

The single point grounding (SPG), otherwise known as the Star—IBN (Isolated Bonding Network), is the standard for the Meridian 1 systems.

The SPG of a system is the point at which an IBN is bonded to ground. Physically, the system SPG is usually implemented as a copper busbar. See Figure 5.

Any of the following busbars can be used as system SPG:

- Building principal ground (BPG), typically in single floor buildings
- Floor ground bar (FGB), typically in multi-floor buildings

Figure 4
DC-powered system with reserve power

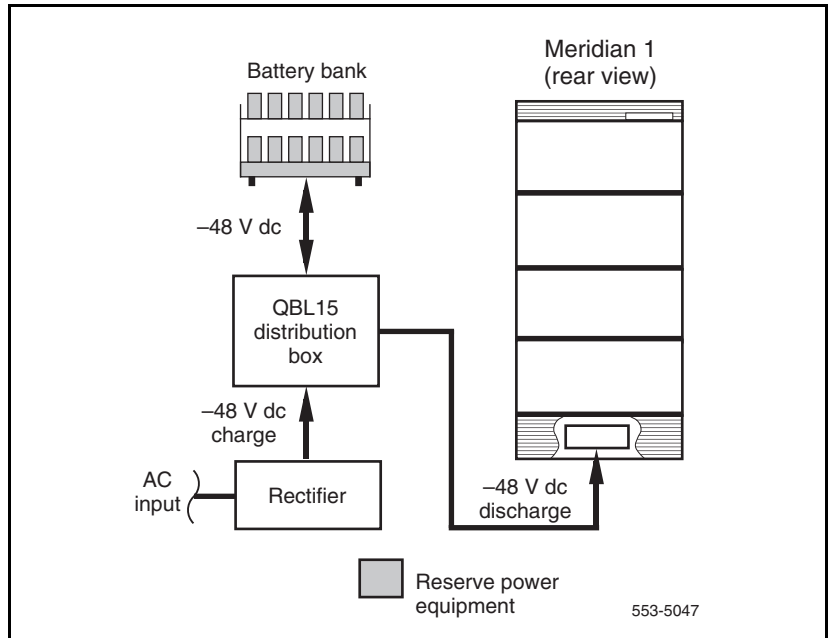

- Dedicated SPG bar bonded to the building grounding system
- A section of the battery return (BR) bar of the power plant.

The various subsystems (such as groups of frames or equipment) of an IBN system can be configured as individual SPG entities, connected in a star configuration to the system SPG (star IBN).

SPG requirements are divided into the following major categories:

- Safety
- Protection
- EMC
- Installation and Maintenance Concern
- Power

Figure 5
Single point ground

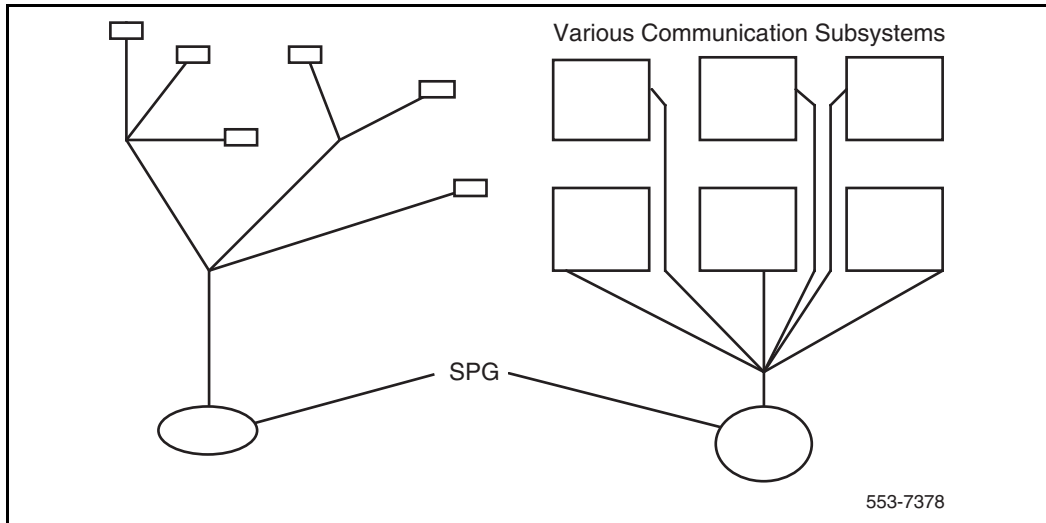

Safety

To ensure a safe working environment for trained company personnel, the customer premises grounding system must be able to dissipate surge energies (such as lightning strikes on the outside plant). In addition, the grounding system must be designed to ensure that fuses or breakers operate to disrupt any excessive current flow caused by a power fault.

Protection

A proper ground is essential to systems protecting equipment. This includes grounding for outside plant cable shields and protectors, as well as the grounds associated with framework, battery, and logic references.

EMC

Grounding must be considered at all times to ensure good Electromagnetic Compatibility (EMC), emission and susceptibility performance.

Installation and maintenance

If included as part of the initial electrical installation for the customer premises, a grounding system is cost effective to install and maintain. Adding a grounding system after the initial installation is complete can be difficult and costly.

Powering

Consider the powering options for the equipment, when planning the grounding system. Look at whether the equipment is backed up with batteries or an uninterruptible power supply (UPS). The grounding and powering of all equipment associated with the telecommunication system should be considered as one large system.

Types of ground

The Meridian 1 has several different grounds and signal returns that are generally referred to as grounds:

- Safety (personal hazard) ground
- Logic return
- Battery return (for DC systems)
- AC “green wire” ground

Safety ground

Figures 6 through 8 illustrate examples of Meridian 1 power and ground connections in several AC system configurations.

If conduit is used to connect AC power from a service panel to the pedestal, it must contain an insulated ground wire (green) that is #6 AWG or larger size. If a cord-and-plug connection is used, a separate safety ground must be provided. The safety ground is required to reduce the risk of electric shock to personnel and avoid system malfunctions under these conditions:

- A telephone wire contacts AC current elsewhere in the building while the AC input cord is unplugged.
- Lightning transients when the cord is unplugged.
- Stray grounds during normal operation.

This safety ground, also known as frame ground or chassis ground, must be an insulated wire #6 AWG or larger, and must connect to both the pedestal safety ground lugs and the service panel ground bus. In all Meridian 1 systems, one 30 A circuit is required for each column. Isolation, as required by NEC 250-74 and 384-27 (exception 1), is preferred.

A single-point ground (SPG) is an isolated ground (IG) bus or AC equipment ground (ACEG) bus in the service panel or transformer. It may also be a separate external bus bar that connects at a single point to the service panel or transformer. Figures 6 through 8 show an isolated ACEG as the single-point ground.

Depending on the distance between columns (and cabinets in upgraded systems) and the service panel, the safety ground wiring may be daisy-chained or run independently from each column (or each row) to the ACEG. Figures 6 through 8 show safety ground wiring in daisy-chain configurations.

Figure 6
AC power—multiple-column distribution

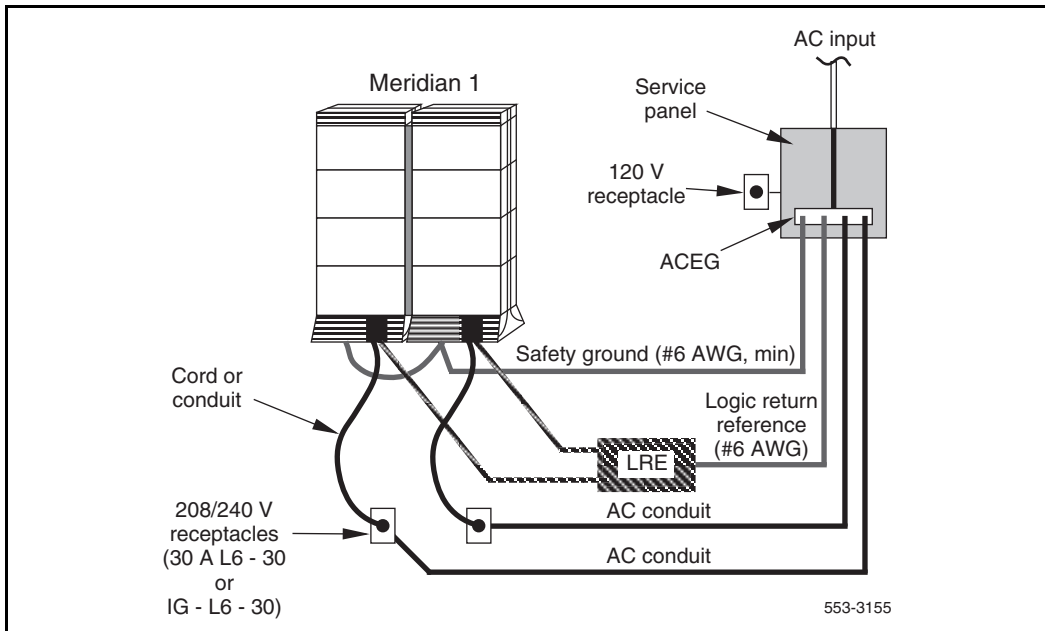

Figure 7
AC power—multiple-row distribution

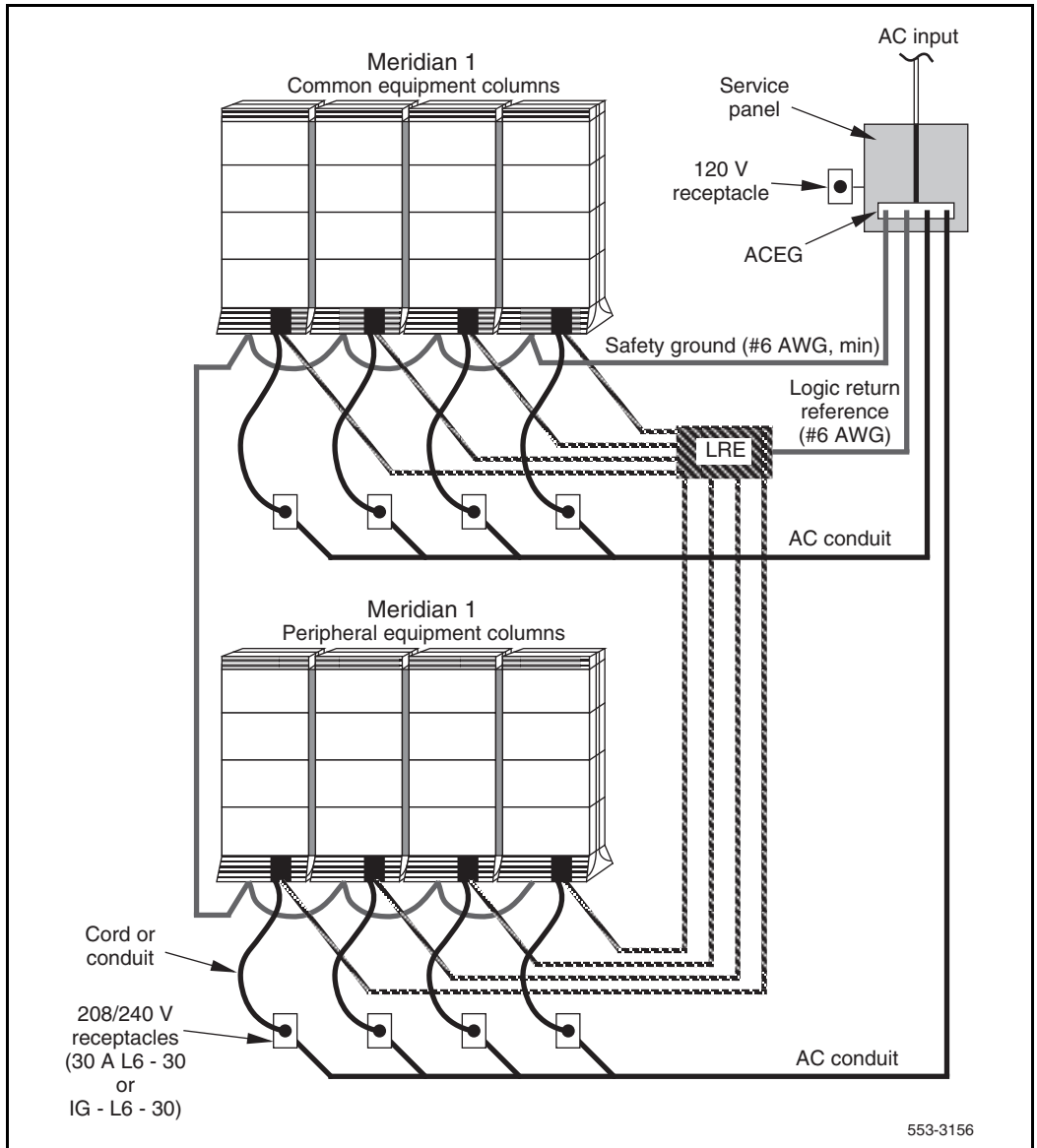
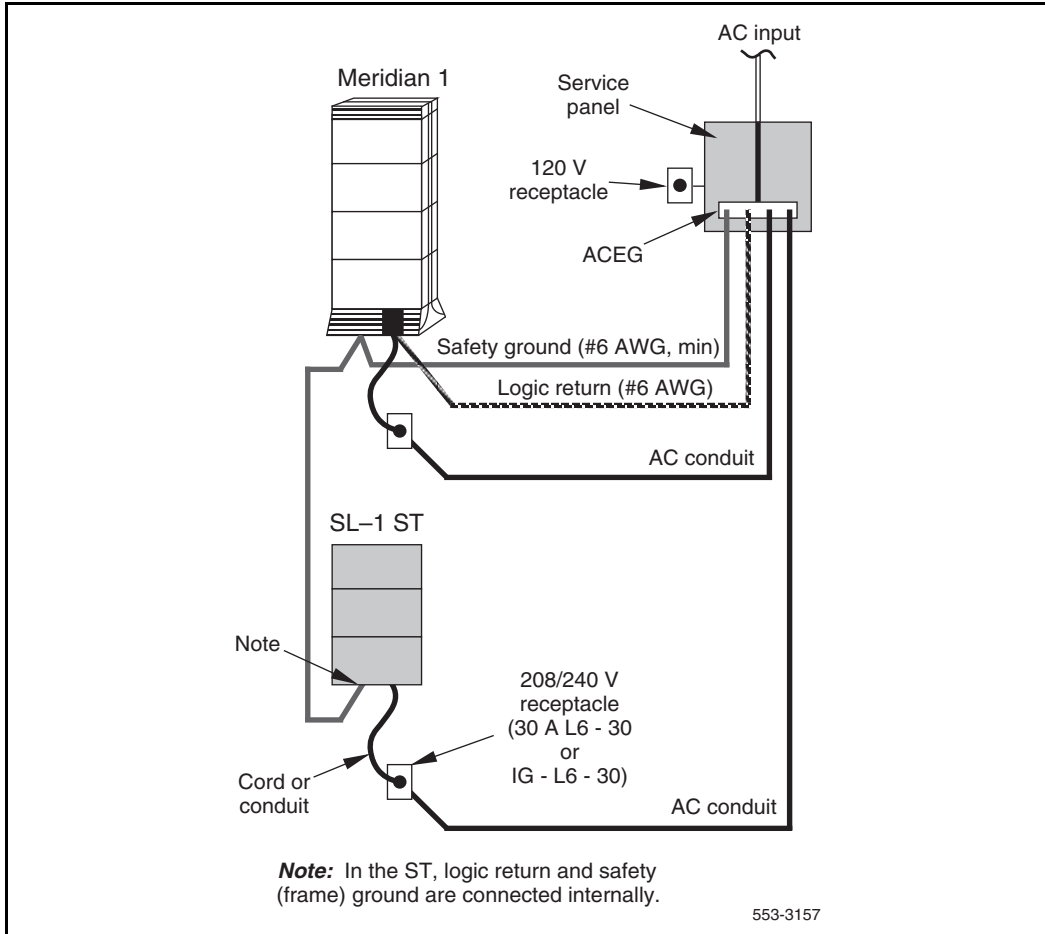

Figure 8
AC power—upgraded system distribution



To implement the single-point ground, follow these guidelines:

- All ground conductors must comply with local electrical codes and be terminated in a manner that is permanent, resulting in low impedance connections.

- All terminations should be readily accessible for inspection and maintenance.
- A grounding conductor must be continuous with no splices or junctions.
- The insulated grounding wire size must comply with the National Electric Code (NEC) Sections 250-94, 250-95, and 310-15.
- Conductors must be insulated against contact with foreign (non-AC) grounds.
- Grounding conductors must be no-load type and carry no current under normal operating conditions.
- The use of building steel as an integral part of the ground system is not recommended.

Logic return

A logic return equalizer (LRE) is a separate bus bar (such as an NT6D5303 or NT6D5304) used to join logic return wires at a common point. A #6 AWG conductor connects the LRE to the ACEG in the service panel. With multiple columns, the LRE is typically located in a nearby rack, in an overhead trough, or under a raised floor. The LRE must be insulated from the AC-grounded support structure. Figures 6 through 8 show the use of an LRE in multi-column configurations.

The logic return equalizer is a consolidation point for all the logic return grounds. It is connected to the AC Equipment Ground (ACEG) which is located within the systems dedicated AC panel. The isolated ground bus within the dedicated AC service panel serves as the “system” SPG. The dedicated AC service panel should be supplied from the buildings principle ground source, usually a transformer which is located within the building. It is at this point that the neutral to ground bond is performed and the live, neutral and grounding conductors are supplied, all together within a single conduit, to the dedicated AC panel for the communication equipment. The dedicated AC panel should service all the communication equipment and any logically interconnected devices (such as modems, TTYs, multiplexers, etc.). This ensures that all equipment has the same ground reference.

The LRE must be insulated from the AC-grounded support structure. Figures 6 through 8 show the use of an LRE in multi-column configurations.

Identifying good grounds

The main ground consists of rods or plates and is considered a good ground when the resistance of the rods or plates to ground is as low as practical. A recognized industrial standard is 5 ohms.

Usually a visual inspection will suffice to ensure that the connection of the ground conductor to the main ground is soundly made. It is possible to verify the quality of the ground by using a three terminal tester. Figure 9 outlines this procedure.

Refer to the three terminal tester manufacturers handbook for testing instructions.

Figure 9
Three terminal testing

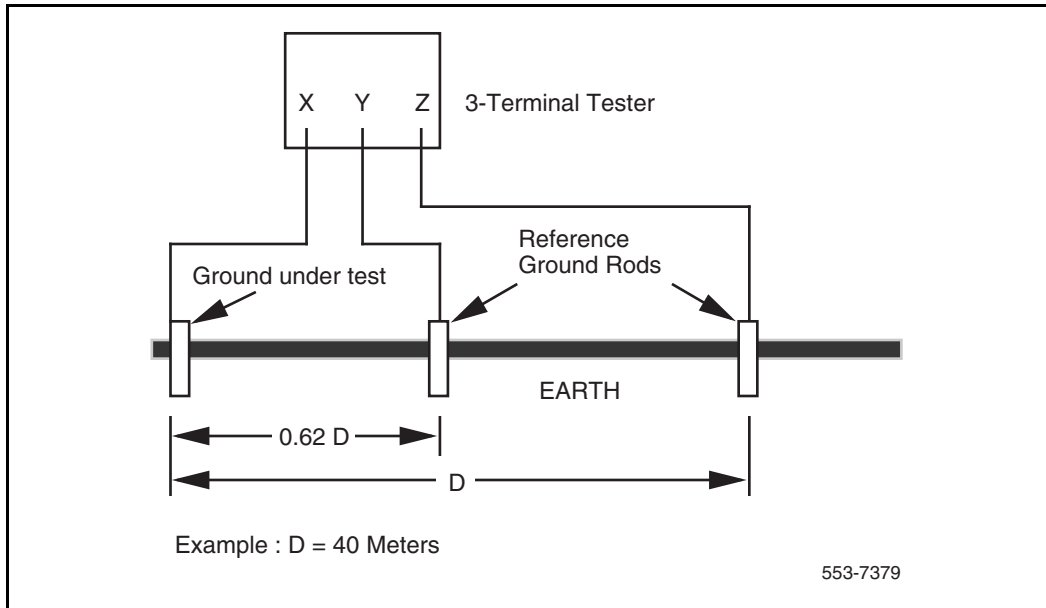

Circuit protection

RS-232 port protection

RS-232 type interfaces are susceptible to induced lightning damage when hardwired lines are run building to building. As little as 25 volts can cause damage. Typically only pins 2 (send), 3 (receive) and 7 (signal ground) are connected end to end via twisted shielded pairs.

Although the RS-232 specification supports only 50 feet of operation, many applications successfully pass data at much longer distances. However, problems arise when different grounds are used at the two ends of the cable. Grounding at both ends will cause a ground loop current to flow in the shield due to the fact that each ground point will most likely be at a different potential. This current flow will induce a voltage onto the signal or data lines resulting in erroneous data or fault conditions.

To prevent the creation of a current loop, the shield must only be grounded at one end and in general this takes place at the system end. SDI ports must be connected to the I/O panel at the rear of the M1 switch. RS-232 cables should then be connected to the I/O panel. RS-232 cables should never be connected directly to the connector on the SDI pack.

A modem or isolator must be installed for all RS - 232 devices not connected to the Meridian 1 AC equipment panel ground.

Off Premises Line Protection

All voice and data lines which run externally from the building that contains the Meridian 1 must have proper line protection. The cable sheath must be connected to the SPG.

Power service panel

Power service panels must meet the following requirements or be modified when used for the Meridian 1:

- Panels should be located in the equipment room.
- No lights, air conditioners, heaters, generators, or motors may be connected to this service panel.

AC power systems

In an AC-powered system, no power components external to the Meridian 1 columns are required. AC systems perform a single conversion from the AC input voltage to the DC voltages required by circuit cards in each module. Optional reserve power is provided by an uninterruptible power supply (UPS) and batteries.

AC power input specifications

AC power supplies operate from a nominal input of 208 to 240 volts AC, single-phase. While the actual input range of the AC power supplies is 180–280 V, no restrapping the power supplies is required if the input line voltage is within 208–240 V.

AC-powered systems require one IG-L6-30 or L6-30 receptacle for each column within 2.4 m (8 ft) of the column's pedestal. Each column comes equipped with one 30 A cord and plug.

Note: Do not use ground fault circuit interrupt (GFCI) devices on Meridian 1 AC power circuits.

As an alternative to using the power cord and plug, AC input to the PDU may be wired directly. Use #10 AWG conductors routed through 1.9-cm (3/4-in.) conduit. Connect the conductors to the input terminals on the field wiring terminal block in the PDU for a 240 V AC input, as indicated in Table 1.

Table 1
AC input connections

AC input conductor	Meridian 1 PDU terminal
Hot—Phase I	L1
Hot—Phase II	L2
Safety Ground	GND

All AC input power wiring must contain a separate safety ground conductor (green wire). Nortel Networks strongly recommends a dedicated AC supply that runs uninterrupted from the building primary source to a dedicated equipment room service panel.

Note: Follow all applicable electrical codes if the AC input is wired directly to the PDU.

If reserve power is used, install the UPS, along with its associated batteries (which may be internal or external to the unit), in series with the commercial power source. The Meridian 1 systems then plug into the UPS (see Figure 2). Consult the UPS manufacturer for requirements of the UPS power input receptacle.

AC internal power distribution

Figure 10 shows the elements of the AC internal power system. Components of the distribution system include the power distribution unit (PDU), module-to-module power harness, module power distribution unit (MPDU), MPDU-to-backplane power harness, and module power supply.

Input power wiring connects to the field wiring terminal block in the back of the PDU. The output power harness connects the field terminal block to the first module. The module-to-module harness distributes power to the MPDU in each successive module. The MPDU-to-backplane harness distribute power from the MPDU to the module power supply and ringing generator, if equipped. The module power supply converts the AC voltage to the DC voltages required by the circuit cards in the module.

Figure 10
AC internal power distribution (rear of the column)

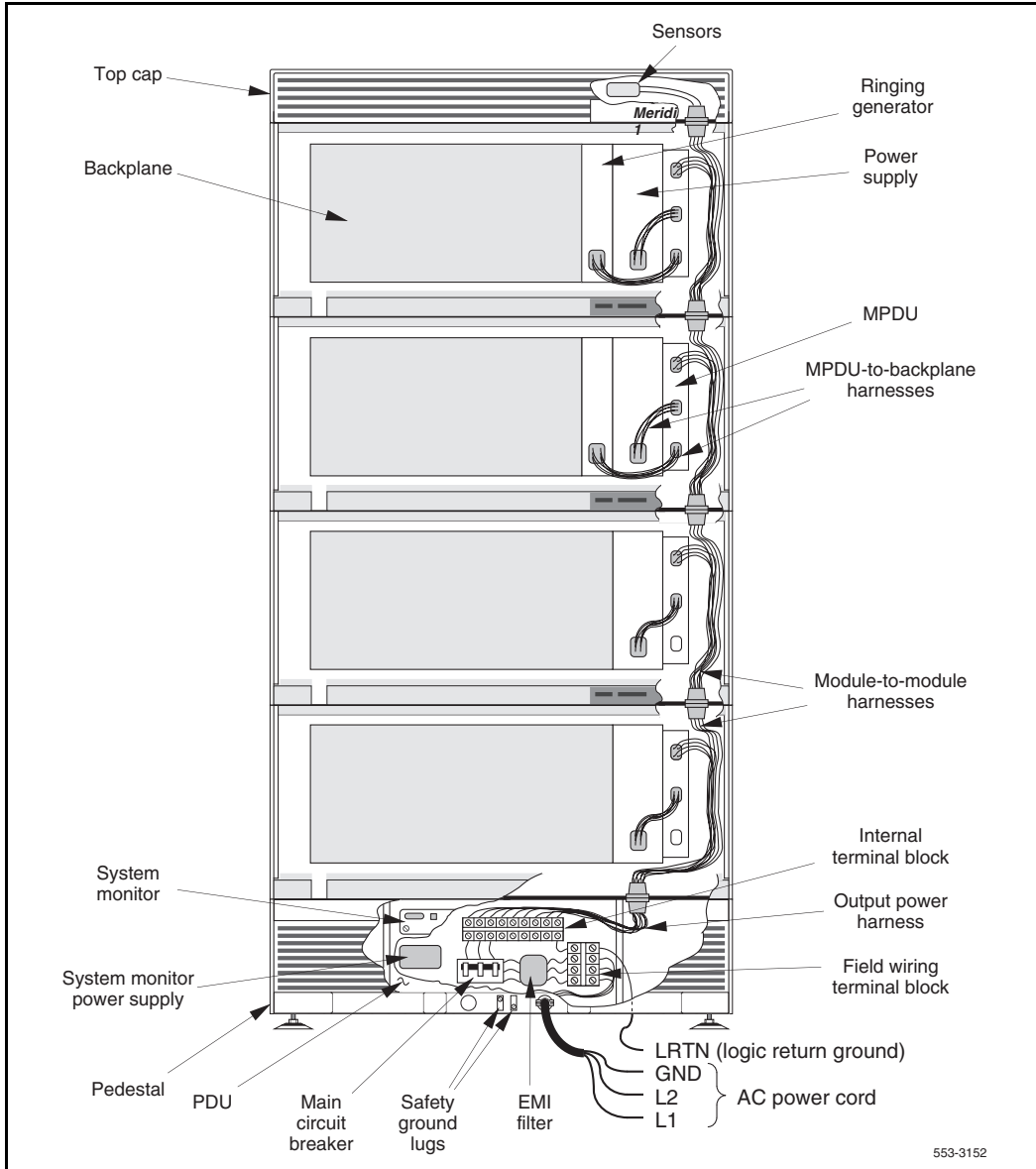

553-3152

Power distribution unit (PDU)

Located in the rear of the pedestal, the PDU serves several functions, but primarily it serves as a power distribution point for the entire column. The field wiring terminal block provides the connection point for the AC input wiring. The electromagnetic interference (EMI) filter (required for regulatory compliance) keeps EMI from radiating outside the confines of the column. The circuit breaker, which is the main circuit breaker for all modules in the column, protects the column if there is a current or thermal overload. The internal terminal block provides a distribution point for power output wiring to the modules. The power/signal harness (not shown in Figure 10) provides power and signal interconnections for the blower unit and system monitor. The system monitor power supply provides +5 V power to the system monitor even when the main circuit breaker is off. The output power harness relays power from the pedestal to the module(s) above it.

Note: The system monitor is housed in the PDU. The system monitor is powered by a small AC power supply, which is not connected to the circuit breaker for the column.

Intermodule harnesses

Several power harnesses conduct the input voltage throughout the column (see Figure 10). The module-to-module harness connects to the MPDU in each module and to the module above. The MPDU-to-backplane harness distributes power from the MPDU to the module power supply and ringing generator, if equipped, through backplane power connectors.

Module power distribution unit (MPDU)

An MPDU provides the circuit breakers that provide current protection at the module level, so only a faulty module is shut down while others remain functional. Table 2 lists the two MPDUs, power supplies, and modules with which each is compatible.

**Table 2
MPDU, power supply, and module compatibility**

MPDU	Power supply	Module
NT8D56AA	NT8D29CE (for options 51C/61C/ 81C)	NT5D21 Core/Network NT8D35AA Network
NT8D57AA	NT8D06PE NT8D21 (ring generator)	NT8D37AA IPE NT8D13AA PE

Module power supplies

In each module, input voltage is carried through the backplane harness to the module power supply where it is converted to the voltages required by the circuit cards in the module. Table 2 lists the compatibility between module, MPDUs, and each power supply.

Table 3 lists the output voltages and currents for AC module power supplies.

Table 3
Output voltages and currents for AC power supplies

Module	Output volts (V ac)	Output amperes	Output volts/ volt-amperes (V ac / VA) (Note)	Output frequency (Hz)
NT8D06 PE Power Supply	+5.1 +8.5 +10.0 -10.0 +15.0 -15.0 -48.0	28.00 4.00 0.50 0.50 17.00 15.00 7.70	—	—
NT8D21 Ringing Generator	-150.0 +70.0 +80.0 +86.0	0.20 0.127 0.111 0.103	70/8 80/8 86/8	25/50 25/50 20/25
NT8D29 CE Power Supply	+5.1 +12.0 -12.0	60.00 2.50 1.00	—	—

DC power systems

The Meridian 1 DC-powered systems require an external DC power plant consisting of rectifiers (also called *chargers* or *AC/DC converters*) and power distribution and control equipment. This equipment continuously charges a bank of batteries (if equipped) and distributes the DC power to each column.

DC-powered systems require two stages of power conversion. The rectifiers convert the input AC voltage into a nominal DC voltage that is adjustable to correspond to the normal float voltage of a battery bank. This DC voltage is distributed throughout the system to each of the modules, where the module power supplies convert this voltage to the voltages required by the circuit cards in the module.

The DC power system must be able to provide the required current and operate within the specifications listed in Table 4. For additional battery voltage requirements, see Table 8, “Battery requirements,” on page 48.

Table 4
Input specifications—DC power system

Input	Pedestal	Battery
Maximum range	-40 to -56.5 V	-42 to -56.5 V
Expected nominal (24 stationary cells)	—	-52.08 V
Expected nominal (23 sealed cells)	—	-51.75 V
Expected nominal (24 sealed cells)	—	-54.00 V
Noise (max C msg)	—	22 dBrnC (See Note)
Note: Without battery, C msg (max) is 32 dBrnC.		

Input power specifications

Meridian 1 DC-power plants require one separate AC input per rectifier, within 1.8 m (6 ft) of the rectifier. The total requirements for commercial AC power input is determined by the number and type of rectifiers used.

Note 1: Do not confuse the output rating of the rectifiers in DC amps with input requirements in AC amps.

Note 2: NT7D10AA and NT7D10DA PDUs with the NT6D53 junction box can be used to distribute the power to Meridian 1 when the power source is at a distance from Meridian 1. Refer to NT6D53 Junction Box and Table A-7 in *System Installation Procedures* (553-3001-210) for junction box implementation and power and ground wire gauges determination for various distances of power source to Meridian 1. Also, refer to “Selecting proper wire size” on page 97 in this manual for determining the required wire size based on the current required and the distance between the power source and Meridian 1. A junction box may be used with the NT7D67CB PDU, but it is not required.

Internal power distribution

Power distribution in the DC-powered Meridian 1 system (see Figure 11) consists of the NT7D67CB PDU, the module-to-module power harness, the module-to-backplane power harness, and the module power supply.

DC power cables connect to the field wiring terminal block where an output power harness carries the input voltage to the first module.

Module-to-module harnesses distribute DC voltage to successive modules. Module-to-backplane harnesses distribute DC voltage to the module power supply and ringing generator, if equipped. In each module, the module power supply converts the DC input voltage to the several DC voltages required by the circuit cards in the module.

Power distribution unit

The PDU, located in the rear of each pedestal, distributes power to the entire column.

Figure 11
DC internal power distribution (rear of the column)

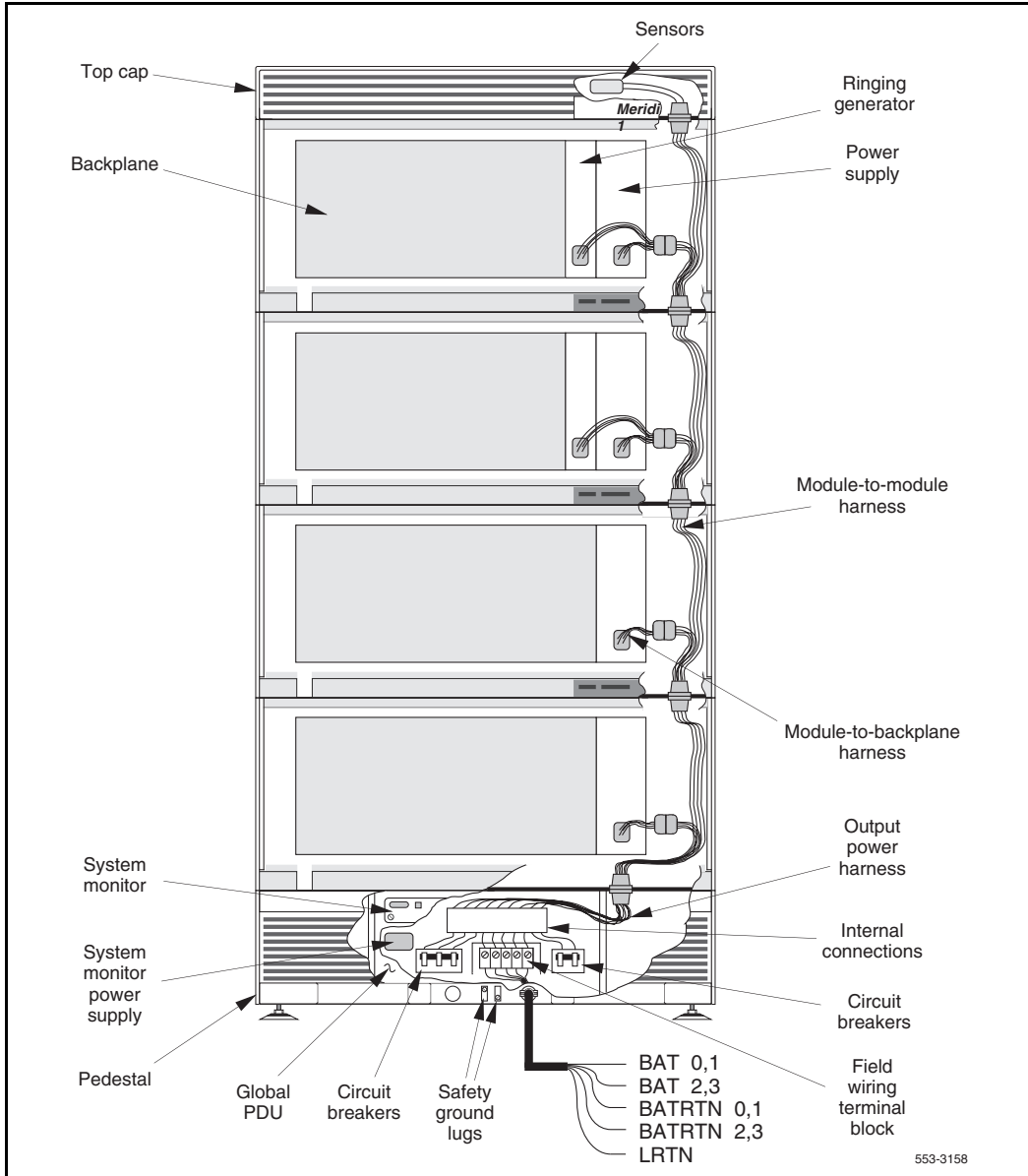

Note: A “global” PDU replaces the one-piece NT7D10AA (North American) and NT7D10DA (European) PDUs. The global PDU consists of an upper NT7D10CA System Monitor/Power Supply Assembly and a lower NT7D67CB Filter/Power Distribution Unit Assembly. Throughout this document, the global PDU is referred to as the “NT7D67CB PDU.” Both NT7D10 (vintage AA or DA) and NT7D67 PDUs may be used in the same system.

The PDU provides a common distribution point for the input voltage. The output power harness connects the pedestal to the first module. Individual wiring harnesses carry the current to each successive module. The power/signal harness (not shown in Figure 11) provides power and signal connections between the blower unit and system monitor.

In the event of a current overload, one of four circuit breakers located in the PDU protects each module. A fifth circuit breaker provides protection for the whole column in the event of a thermal overload. The system monitor power supply provides +5 V power to the system monitor (even when the PDU circuit breakers are off).

Note: The system monitor is housed in the NT7D10CA System Monitor/Power Supply Assembly. The system monitor is powered by a small +5 V power supply, which is not connected to the column circuit breakers.

Intermodule harnesses

Several power harnesses conduct the input voltage throughout the column. The module-to-module harness consists of the module connector, which distributes power to the module or modules above it, and the backplane connector, which distributes power through the module-to-backplane harness to each module power supply.

Module power supplies

In each module, -48 V is received through the module-to-backplane distribution harness and converted by the module power supply to the necessary voltages for the individual module. There is an on/off switch on each power supply for safe operation and easy maintenance.

There are five DC module power supplies:

- 1 The NT5K12AA Power Supply (EPEPS) (International) provides all power for the Enhanced Existing Peripheral Equipment (EEPE) module and includes the ringing generator.

Note: The NT5K12BA is not equipped with –120 or –150 V dc message waiting supply.

- 2 The NT6D40 PE Power Supply provides power to circuit cards and talk battery to lines and trunks.
- 3 The NT6D41 CE Power Supply provides power to circuit cards.
- 4 The NT6D42 Ringing Generator (replaces NT7D03) provides –150 or –100 V dc message waiting lamp voltages for 500/2500 telephones. It can provide ringing power to 48 ringers simultaneously.
- 5 The NT6D43 CE/PE Power Supply (replaces NT7D04) provides power to circuit cards, talk battery to lines and trunks, and ringing and message waiting lamp voltages for 500/2500 telephones.

Table 5
MPDU, power supply, and module compatibility

Power supply	Module
NT6D40PE	NT8D13DC PE NT8D37DC IPE
NT6D41CE	NT5D21 Core/Network NT6D60BA Core NT8D35DC Network
NT6D42 ring generator (replaces NT7D03)	NT8D13DC PE NT8D37DC IPE
NT6D43 (replaces NT7D04)	NT8D11DC CE/PE NT8D47DC RPE

Table 2, “MPDU, power supply, and module compatibility,” on page 30 lists power supply compatibility and Table 6 lists the output voltage and currents for DC power supplies.

Table 6
Output voltages and currents for DC power supplies

Power supply	Output volts	Output amperes	Output volts/ volt-amperes (V ac / VA) (Note)	Output frequency (Hz)
NT5K12 EPE Power Supply (International)	+5.0	0.75	70/8.0	20/25/50
	+6.0	4.00	75/8.0	20/25/50
	-6.0	4.00	80/8.0	20/25/50
	+10.0	0.80	86/8.0	20/25/50
	-10.0	0.80		
	+15.0	7.20		
	-15.0	7.20		
	-48.0	5.00		
	-120.0	0.20		
-150.0	0.20			
NT6D40 PE Power Supply	+5.1	28.00	—	—
	+8.5	4.00		
	+10.0	0.50		
	-10.0	0.50		
	+15.0	17.00		
	-15.0	15.00		
	-48.0	7.70		
NT6D41 CE Power Supply	+5.1	60.00	—	—
	+12.0	3.50		
	-12.0	1.00		
NT6D42 Ringing Generator	-100.0	0.20	70/16	20/25/50
	-150.0	0.20	75/16	20/25/50
	70.0	0.127	80/16	20/25/50
	80.0	0.111	86/16	
	86.0	0.103		
NT6D43 CE/PE Power Supply	+5.1	60.00	70/16	20/25/50
	+8.5	2.50	75/16	20/25/50
	+12.0	1.00	80/16	20/25/50
	-12.0	0.75	86/16	
	+15.0	10.00		
	-15.0	10.00		
	-48.0	4.95		
	-120.0	0.20		
	-150.0	0.20		

External power distribution

A variety of rectifiers and distribution equipment can be used to supply external DC power. Existing customer equipment can be used or a system that Nortel Networks either supplies or recommends. In any case, equipment for rectification and distribution is required, while reserve batteries are optional.

NT0R72 Switched Mode Rectifier

The NT0R72 Switched Mode Rectifier is used with system options 51C, and 61C. This rectifier converts a range of input voltages (from 176 to 280V) to -48 V dc up to a maximum output of 25 A. NT0R72 rectifiers are used to replace defective NT6D52 rectifiers or to expand the power capacity of an existing NT7D12 Rectifier Rack Assembly.

The rectifier connects to the Meridian 1 system through the QBL15 Power Distribution Box. Generally, one rectifier is needed for every two fully loaded modules. The exact quantity required depends on the system configuration and power requirements.

Up to three NT0R72 rectifiers can be installed in the NT7D12 Rectifier Rack Assembly. Up to two rectifier racks can be used for each system. This provides a total of six rectifiers (see Figure 12). Each rectifier is mounted in the rack using a NT7D1201 Rectifier Support/Air Baffle, which consists of a set of rectifier support brackets and a heat baffle plate. One kit is required for each rectifier.

The NT7D1204 Mounting Hardware kit is used to mount an NT0R72 rectifier on to the NT7D12 Rack.

Each rectifier comes equipped with a QCAD274 Rectifier Cord and requires one L6-20 locking receptacle for each rectifier.

QBL15 Power Distribution Box

The QBL15 (see Figure 13) is a common connection point for the rectifier output and battery backup power, and common distribution point for DC power and power monitor signals. Up to three NT0R72 rectifiers can be connected to a QBL15, as can backup battery output. Two QBL15s must be used to support two NT7D12 Rectifier Rack Assemblies.

The QBL15 can also be used to connect NT0RL72 or rectifiers with existing QRF12 or NT0R71 rectifiers in a load sharing arrangement (for more information on load sharing, see “Powering upgraded systems from existing rectifiers” on page 92 in the “Component power consumption” chapter).

Also built into the QBL15 are a QPC188 battery monitor card, test points, and fused sense leads for each rectifier. A maximum of two QBL15 distribution boxes can be used per system.

For installation procedures, see *System Installation Procedures* (553-3001-210).

Figure 12
NT7D12 Rectifier Rack Assembly with three NT0R72 rectifiers

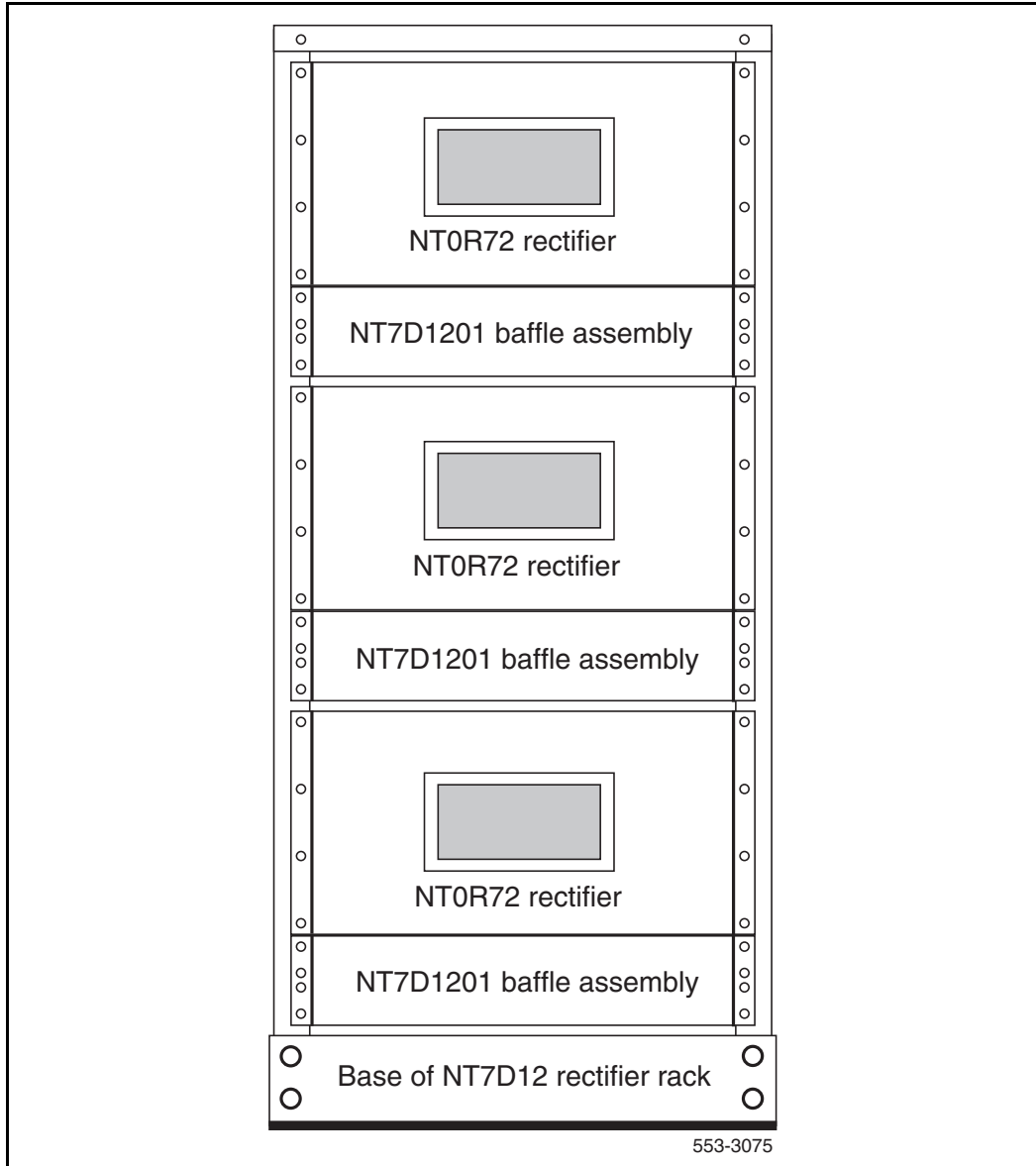
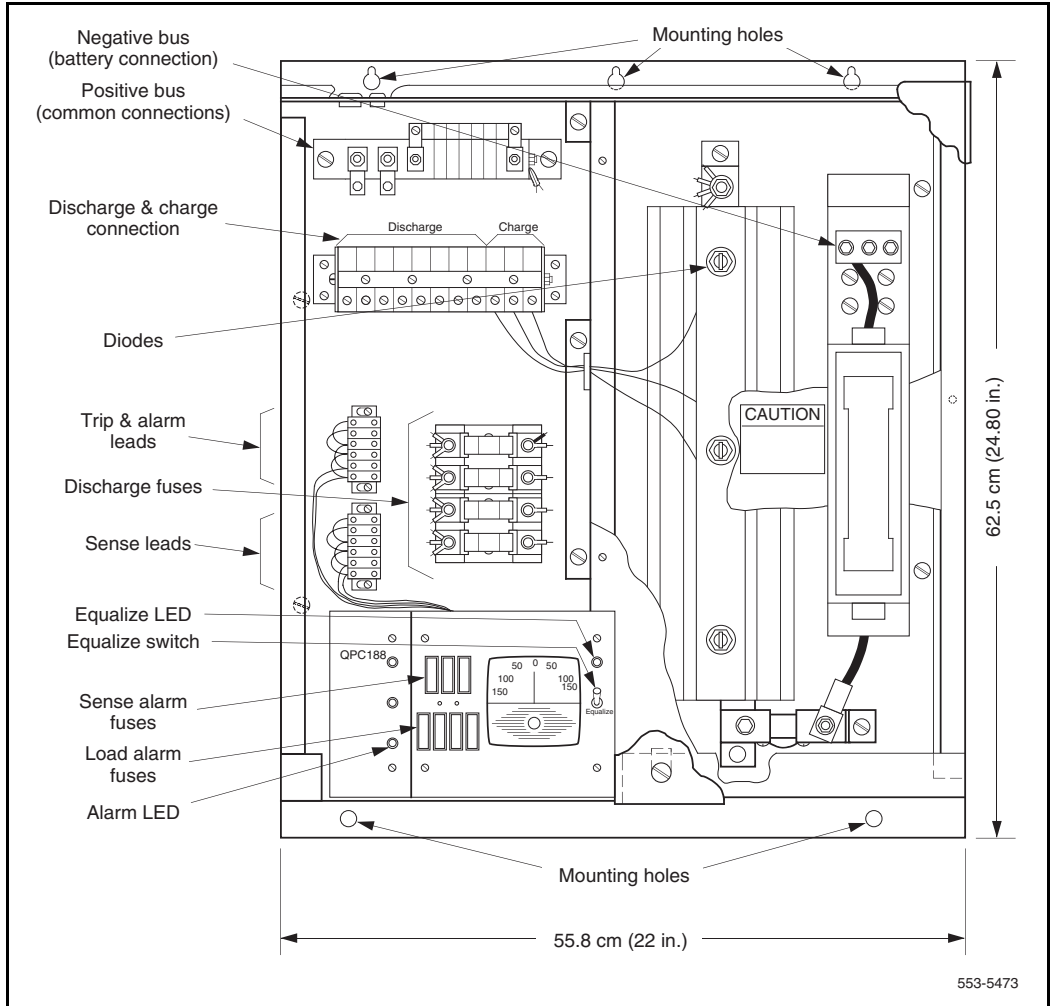

Figure 13
QBL15 Power Distribution Box



Reserve power

Reserve power is available for both AC and DC systems. When selecting reserve power equipment, consider:

- Future system growth
- Maximum time back-up power is required
- Existing power system capacity
- Space and thermal environment (air conditioning)
- Other equipment, such as lights and alarm systems

Reserve power for AC systems is provided by uninterruptible power supplies (UPS), installed in a series with the commercial power source. A UPS generally consists of a combination battery charger (AC/DC converter) and inverter (DC/AC converter), along with associated batteries. The batteries may be internal or external to the UPS. A UPS is not a standby power source, but an on-line unit with no output interruption when the AC power is interrupted.

DC systems use the traditional telecommunications powering method: external rectifiers (AC/DC converters) continuously charge a bank of batteries while the system power “floats” in parallel on the battery voltage.

AC reserve power

There are a number of UPS vendors and systems available. Factors to consider when choosing a UPS include:

- Input voltage and frequency range
- Output voltage and current capacity
- Number and type of output receptacles
- Regulatory and safety agency approvals
- Efficiency and performance considerations
- Alarm and status indications
- Battery recharge time
- Maximum time backup power is required

- Existing batteries or other power equipment available at the site
- Future system growth

UPS sizing

To determine UPS sizing, first calculate the total power requirements of the column (or columns) supported by the UPS, as described later in the chapter “Component power consumption” on page 85. Convert the real power in watts (W) to complex or “apparent” power in volt-amperes (VA) by dividing the real power by the typical system power factor of 0.6. Then size the UPS in terms of its rating in VA (or kVA). For AC-powered Meridian 1 systems, Autoquote calculates the system power consumption in both watts and volt-amperes.

$$\text{VA} = \frac{\text{W}}{0.6}$$

To determine the sizing and provisioning of UPS batteries, follow the instructions provided by the UPS manufacturer. A general approach, however, is to take the total system power in watts, divide by the UPS inverter efficiency, and convert to battery current drain by dividing by the nominal discharge voltage of the battery string. Then multiply the battery current drain by the time needed for the reserve power to operate to determine the battery requirements in ampere-hours (A-hrs).

$$\text{Ahr} = \left(\frac{\text{W}_{\text{total}}}{\text{V}_{\text{dischg}}} \right) T_{\text{reserve}}$$

UPS interfacing

A UPS must meet the following requirements in order to be used with Meridian 1 systems:

- The UPS specifications must meet the commercial power specifications of the Meridian 1:
 - Nominal output voltage range of 208–240 V AC, with a total input range of 180–250 V AC
 - Nominal frequency of 50–60 Hz, with a total range of 47–63 Hz
 - Total harmonic distortion (THD) of 5%, with 3% on any single harmonic, of the AC sine wave

- The UPS must be able to handle a non-linear loads (the AC module power supplies are a switched-mode design) and have a current crest ratio of 3.0 or greater.
- The UPS must be UL listed and certified under FCC Part 15, Subpart J as a Class A device.
- The UPS must have a 30 A, 250 V locking power receptacle (L6-30) for each Meridian 1 column to be powered.
- The UPS must meet ANSI standard C62.41 and IEEE standard 587-1980, class A and B, for transient surge suppression.

Note: It is convenient for the UPS to have one or more 120 V power outlets (5-15R) for auxiliary devices that must have backup power, such as the power fail transfer unit power supply.

UPS installation

When installing a UPS, follow the vendor's instructions carefully.

Note: UPS installation can be complex. Nortel Networks recommends taking advantage of vendor training programs.

It is recommended that a bypass switch be installed during the initial UPS wiring (if the switch function is not inherently a part of the UPS itself). The UPS bypass switch allows the Meridian 1 to run directly from the commercial power source while the UPS is taken off-line during installation, service, or battery maintenance.

CAUTION
Equipment damage

Take care when connecting battery cables to the UPS. Connecting battery cables backward can result in severe damage to the UPS.

Figure 14 shows a general block diagram of a UPS installation and associated wiring.

Figure 14
AC reserve power configuration

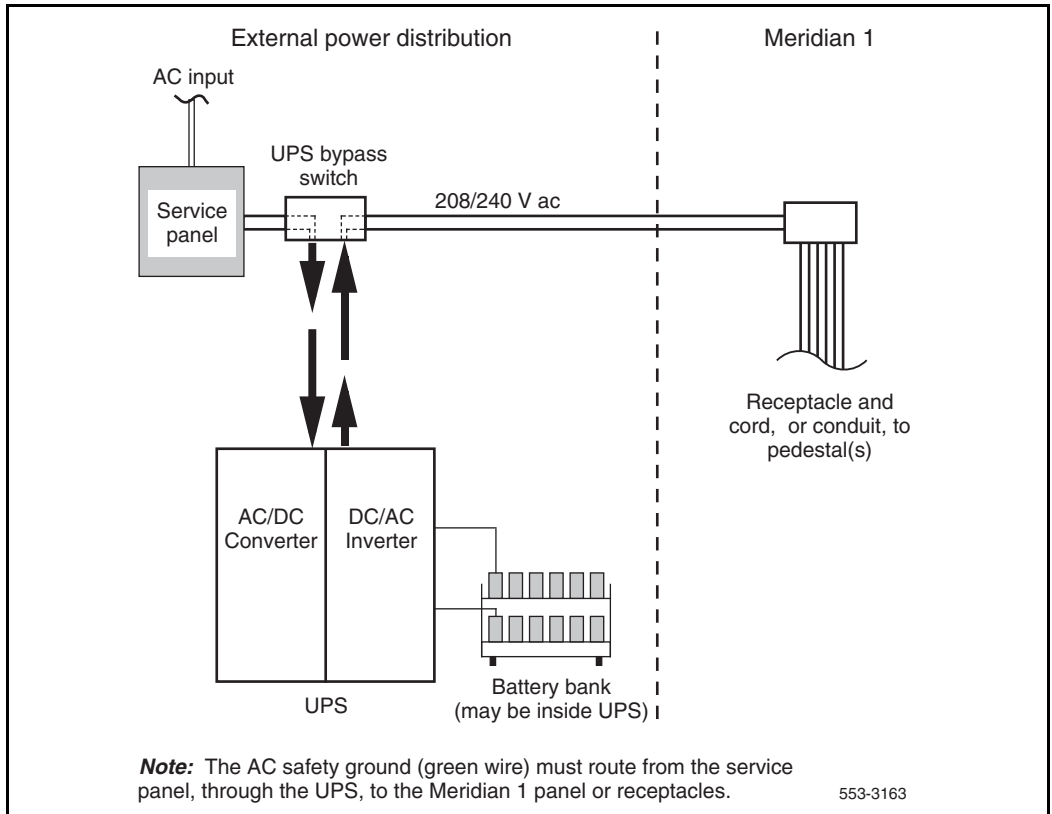

Power conditioning

The term “power conditioner” refers to a wide variety of power protection or power quality improvement devices, such as low-pass filters, surge arrestors, line voltage regulators, and isolation transformers. Most of these devices can help prevent power line spikes and surges, and some isolation transformers can provide good noise rejection.

Although most power conditioning devices do not provide energy storage for undervoltage conditions, they can help prevent surges and other overvoltage conditions that can cause permanent damage to equipment.

When choosing UPS protection and power conditioning equipment, remember that over 90 percent of power disturbances in the U.S. are undervoltage conditions such as sags and outages. When there are U.S. power disturbances:

- 87% are power sags; 90% of these last 0.53 seconds or less
- 7.4% are impulses or spikes lasting less than 100 microseconds
- 4.7% are longer-term power failure; 90% of these last 4.2 hours or less, 75% last 40 minutes or less, and 50% last 38 seconds or less
- 0.7% are surges lasting more than 100 microseconds

Low voltage transients occur most frequently and may cause temporary loss of operation. High voltage transients occur much less often, but can cause damage to equipment as well as loss of operation.

Carefully consider the type of power line protection needed for the installation under consideration. A power conditioner can help provide overvoltage protection, but a UPS can (usually at a higher price) provide both overvoltage and undervoltage protection.

Alarm monitoring

Nortel Networks offers a system monitor to UPS interface cable for each of the product lines that have been tested for Meridian 1 compatibility. The system monitor interface is not supported for other vendors. Table 7 lists the UPS-to-system monitor alarm cables that are available. UPS systems are not offered by, or available through Nortel Networks, but can be purchased directly from vendors or through authorized distributors.

The alarm interface consists of an “Inverter On” signal to indicate that the commercial power is interrupted and the UPS alone is supplying power to the system, and a “Summary Alarm” signal to indicate a fault or alarm condition at the UPS.

Table 7
UPS-to-system monitor alarm cables

UPS vendor	Cable part number	Quantity
Alpha Technologies	NT8D46AU	one per UPS
Best Power Technology	NT8D46AJ	one per UPS
Exide Electronics	NT8D46AQ	one per UPS

DC reserve power

Reserve power for DC systems is provided by adding batteries to the external power distribution system. Calculate reserve battery capacity as shown in “UPS sizing” on page 43. This determines the total ampere-hour requirements of the batteries (see also “Component power consumption” on page 85).

To comply with safety requirements, read and fully understand the following documents before working with any battery systems:

- OSHA “Material Safety Data Sheet” that must be posted to meet OSHA requirements. This document outlines safe reserve battery handling procedures.
- National Electric Code 645-10. This document outlines requirements that call for the installation of AC- and DC-power kill switches to battery systems in certain environments.

Current requirements

The DC current required for battery reserves is based on the total system power requirement. For new installations you can determine power and battery requirements from data provided by Nortel Networks. For existing installations, see “Component power consumption” on page 85 for information on calculating current required for battery reserves.

Batteries

The reserve battery capacity required depends on the system line size (load), the time the reserve supply must last in the event of a power failure, and the battery end voltage. Table 8 gives guidelines for reserve battery float and equalization voltages. These voltages must never be more negative than -56.5 V.

Table 8
Battery requirements

Battery configuration	Float voltage (V)		Equalize voltage (V)	
	Cell	Bank	Cell	Bank
24 stationary cells	-2.17	-52.08	-2.25	-54.00
23 sealed cells	-2.25	-51.75	-2.35	-54.05
24 sealed cells	-2.25	-54.00	-2.35	-56.40

Lead-calcium/absolyte batteries

Battery package provisioning is based on the number of Amp-hours required. Since battery package Amp-hour ratings are generally given at an eight hour discharge rate, adjustment factors are required to determine the required battery package. Table 9 lists adjustment factors for lead-calcium and absolyte batteries. These factors are based on the discharge rates of the respective battery types from a specific supplier. Discharge characteristics may vary by manufacturer.

Table 9
Adjustment factors for lead-calcium and absolyte batteries (Part 1 of 2)

Reserve Hours	Lead Calcium Factor	(Sealed) Absolyte Factor
1	3.0	1.8
2	4.0	3.1
3	5.0	4.2

Note: If a system requires more than 10 hours of backup, the factor is linear. For example, if 15 hours are required, the factor is 15.

Table 9
Adjustment factors for lead-calcium and absolyte batteries (Part 2 of 2)

Reserve Hours	Lead Calcium Factor	(Sealed) Absolyte Factor
4	5.9	5.2
5	6.9	6.2
6	7.7	7.1
7	8.5	7.8
8	9.3	8.5
9	10.1	9.4
10	10.9	10.2

Note: If a system requires more than 10 hours of backup, the factor is linear. For example, if 15 hours are required, the factor is 15.

Calculate battery requirement using this formula:

$$\text{Ahr} = I_L \times F_{\text{adj}}$$

where

Ahr = battery requirement in amp-hours

I_L = system load, in amps

F_{adj} = appropriate adjustment factor from Table 9

When using lead-calcium or sealed batteries, calculate battery recharge time using this formula:

$$T = \frac{\text{Ahr} \times 1.15}{I_{\text{RO}} - I_L}$$

where

T = battery recharge time

Ahr = battery capacity in amp-hours

I_L = total system load, in amps

I_{RO} = total rectifier output, in amps

Other battery considerations are:

- Not all sealed cells require equalization, but equalization voltage can be used for fast charging. Use a battery end voltage of 44 V when choosing battery banks.
- Use these electrical noise limitations for a battery bank:
 - 20 mV rms maximum ripple
 - 32 dBrnC maximum noise
- CEMF cells are not recommended because the noise they generate is unacceptable.

Meridian 1 power plants

Contents

This section contains information on the following topics:

Introduction	51
Reference list	51
MFA150 Modular Power System	52
MPP600 Modular Power Plant	57
System 600/48	60
J2412 Power Plant	67
NT6D82 Power System	73

Reference list

The following are the references in this section:

- *Installation Planning* (553-3001-120)
- *System Installation Procedures* (553-3001-210)

Introduction

Meridian 1 has several DC power plant options:

- MFA150 Modular Power Plant
- MPP600 Modular Power Plant (replaced by System 600/48 Power Plant)
- System 600/48 Power Plant
- J2412 Power System
- NT6D82 Power System

These power systems are called “DC” because they deliver DC to the pedestal of the Meridian 1 system. AC-powered systems accept AC at the pedestal and distribute AC to the power supplies located in each module.

This section discusses the function and installation considerations of these four DC power systems. A discussion of uninterruptible power supplies (UPS) and reserve power using batteries is also provided.

The terms “AC system” and “DC system” refer to the type of power brought into the pedestal and distributed within the system to the module power supplies. Figure 1 on page 14 and Figure 2 on page 15 show the basic power distribution for AC and DC systems. All Meridian core systems are available in both AC power and DC power versions.

MFA150 Modular Power System

The MFA150 is a modular, front access power system with a –48 V DC output and a capacity of 150 A, provided in 25 A increments by MPR25 plug-in rectifier modules. The MPR25 Modular Power Rectifier and MPS75 Modular Power Shelf are the main system components (see Figure 15).

The MFA150 can be used with all Meridian 1 DC-powered systems as a replacement for NT6D52 rectifiers, NT0R72 rectifiers, in combination with a QBL15 Power Distribution Box. However, in large systems such as system options 71, 81, and 81C, the MFA150 should be used only if the system configuration does not require more than 150 A. Other switchroom equipment that requires –48 V DC power may also be powered from the MFA150 as long as there are sufficient output circuit breakers or auxiliary fuses, the total load does not exceed 150 A, and a consistent single-point ground topology is maintained for all associated equipment.

Two configurations of the MFA150 are available for Meridian 1 systems:

- The NT5C90EF has a single MPS75 shelf with a capacity of 75 A.
- The NT5C90EG is a dual-shelf configuration with a capacity of 150 A.

Note: Both configurations are seismic zone 4 approved.

Each of these configurations is a complete power bay, with an NT6C14 Control and Distribution Panel mounted on an NT6C40 Seismic Rack as shown in Figure 15. A power bay is a relay rack for power equipment and contains the power distribution and control circuitry.

The MPR25 is a switched mode rectifier that operates on single-phase, 50/60 Hz, AC service on either 208 or 240 V nominal input. The power system can operate with or without a -48 V DC battery bank for reserve power capabilities. If batteries are connected, the rectifiers can operate in either the float or equalize mode.

The system has a variety of monitoring and alarm features, such as high and low voltage alarms, fuse and breaker alarms, rectifier failure alarms. An interface to the NT8D22 System Monitor provides a subset of these alarms.

The MFA150 also provides built-in AC power conditioning and surge protection, and digital voltage and current meters for monitoring of overall system and individual rectifier status. A low-voltage disconnect (LVD) battery protection feature disconnects the batteries prior to complete exhaustion, and automatically reconnects them after AC power is restored. Two optional internal battery trays help to reduce floor space requirements.

One MFA150 is required for each DC-powered system. Depending on the system power consumption, up to two MPS75 shelves and six MPR25 rectifiers may be equipped.

Figure 15
MFA150 Modular Power System with six MPR25 rectifiers

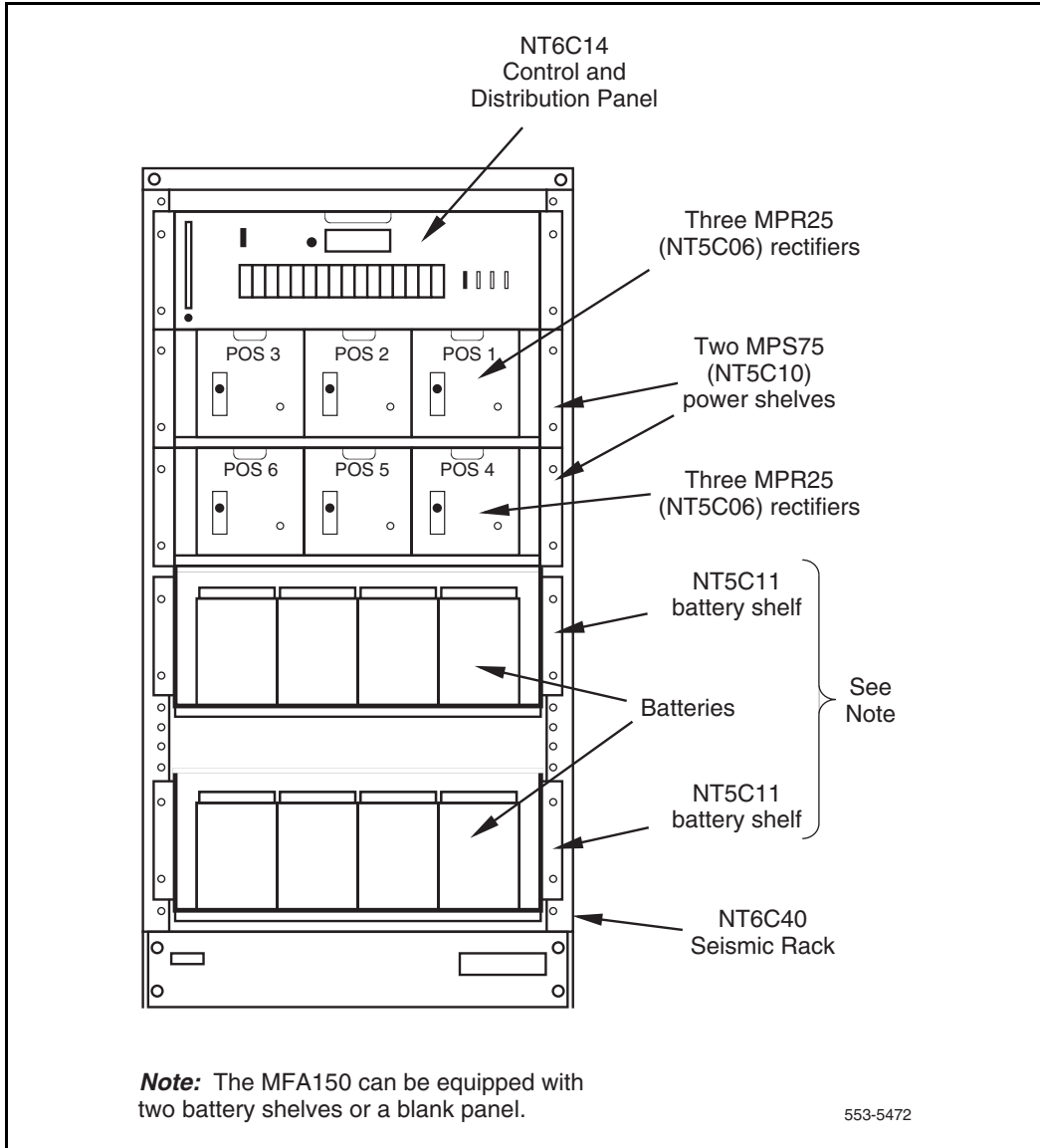

Specifications

Selected specifications used for system engineering and site planning are listed in Table 10.

Table 10
MFA150 specifications (Part 1 of 2)

Specification	Characteristic	Min	Nominal	Max
Input voltage	Voltage (V ac)	176	208–240	264
	Frequency (Hz)	47	50–60	63
	AC input wiring requires one 50 A, hard-wired, AC circuit per shelf which will accommodate three MPR25 rectifiers.			
Output voltage	Float (V DC)	46	54.0*	56
	Equalize (V DC)	50	55.5	65
	* Factory set output float voltage is 54 V DC, to accommodate a standard 24-cell battery string of 2.25 V per cell (typical VRLA batteries). System output current is 25 A with one MPR25 rectifier, to a maximum of 150 A with six MPR25 rectifiers.			
Noise specifications	Wideband noise:	<100 mV rms	(<5 mV, typical)	
	(10 kHz –20 MHz)	<250 mV peak-peak	(<175 mV, typical)	
	Voiceband noise	<22 dBrnC	(<15 dBrnC, typical)	
Note: Measured at output, with or without batteries under worst-case conditions. These specifications are maintained under all operating conditions, including surge conditions previously described.				

Table 10
MFA150 specifications (Part 2 of 2)

Specification	Characteristic	Min	Nominal	Max
Mechanical specifications	Overall dimensions of the NT6C40 Seismic Rack: H=127.0 cm (48 in.) W=61.9 cm (24.38 in.) D=38.1 cm (15 in.)			
	Weights:			
	MPR25 Rectifier		6.7 kg (14 lb)	
	MPS75 Shelf		10.5 kg (23 lb)	
	NT6C14GB Control Panel		24.5 kg (54 lb)	
	NT6C40 Seismic Rack		15 kg (33 lb)	
	System configurations		Weight empty (without rectifiers)	Weight full
	NT5C90EF, single-shelf		50 kg (110 lb)	69.1 kg (152 lb)
	NT5C90EG, dual-shelf		60.5 kg (133 lb)	98.6 kg (217 lb)
	Floor loading (no batteries) 489 kg/m ² (100 lb/ft ²)			
Miscellaneous	Heat dissipation	150 W, or 512 BTU per hour, per rectifier		
Standards compliance	Standard: ANSI Std C62.41/IEEE Std 587-1980, Class A and B lightning surge			
	Specification: 6000 V, 3000 A, 1.2 x 50 μs impulse, 10 hits per second			
	Standard: ANSI Std C62.41 oscillatory surge			
	Specification: 2500 V, 0.5 μs impulse, 100 kHz positive/negative oscillating decay			
	Standard: Bellcore TR-TSY-000947			
	Mean time between failures (MTBF) of each rectifier	>120,000 hours, per Bellcore standards		

MPP600 Modular Power Plant

The MPP600 Power Plant is a positive ground, –48 V DC, 600-A power plant. It can be used with all Meridian 1 DC-powered systems, but is optimized for larger system configurations such as system Options 81, and 81C. Other switchroom equipment that requires –48 V DC power may also be powered from the MPP600, as long as there are sufficient output circuit breakers or auxiliary fuses, the total load does not exceed 600 A, and a consistent, single-point ground topology is maintained for all associated equipment.

Note: The MPP600 Power Plant has been replaced by the System 600/48 Power Plant for all new installations.

The MPP600 consists of either one main cabinet (for loads requiring up to 300 A) or one main and one supplemental cabinet (for loads up to 600 A), a common equipment panel, distribution and control panels, and rectifier shelves. The MPP600 utilizes up to twelve 50-A switch mode rectifiers (MPR50) as building blocks connected in parallel to reach the maximum capacity of 600 A. This maximum capacity may be attained without power interruption to the load.

The rectifiers operate on single-phase 50 or 60 hertz AC service from either 208 V or 240 V nominal input. The power system may operate with or without –48 V DC batteries for reserve power. If batteries are connected, the rectifiers can operate in either the float or equalize mode.

The MPP600 is designed with access from the front and the rear; all operational controls are accessible from the front of the unit. It is designed for seismic environments to Zone 4 (Bellcore) free standing configurations, with no external bracing required.

The MPP600 has a variety of monitoring and alarm features, such as high and low voltage alarms, fuse and breaker alarms, rectifier failure alarms, and low voltage disconnect. An interface to the NT8D22 System Monitor provides a subset of these alarms.

Specifications

Selected specifications used for system engineering and site planning are listed in Table 11.

Table 11
MPP600 specifications (Part 1 of 3)

Specification	Characteristic	Min	Nominal	Max
Input voltage	Voltage (V ac)	176	208 or 240	264
	Frequency (Hz)	47	50 or 60	63
AC input wiring requires one 25 or 30 A hard-wired AC circuit per MPR50 rectifier.				
Output voltage	Float (V DC)	46	54.0*	56
	Equalize (V DC)	50	55.5	65
<p>Note: Factory set output float voltage is 54 V DC, to accommodate a standard 24-cell battery string of 2.25 volts per cell (typical VRLA batteries).</p> <p>Note: System output current is 50 A per MPR50 rectifier, to a maximum of 600 A with 12 MPR50 rectifiers in 2 cabinets.</p>				
Noise specifications	Wideband noise:	<100 mV rms	(typical is <5 mV)	
	(10 kHz –20 MHz)	<250 mV peak-peak	(typical is <175 mV)	
	Voiceband noise	<22 dBnC	(typical is <15 dBnC)	
<p>Note: Measured at output, with or without batteries under worst-case conditions. These specifications are maintained under all operating conditions, including surge conditions previously described.</p>				

Table 11
MPP600 specifications (Part 2 of 3)

Specification	Characteristic	Min	Nominal	Max
Mechanical specifications	MMP600 main or supplemental cabinet:	H=182.9 cm (72 in.) W=72.4 cm (28.5 in.) D=72.4 cm (28.5 in.)		
	Weights			
	MPR50 Rectifier (NT5C07)	9 kg (19.8 lb)		
	CE Panel (NT6C31AB)	16 kg (35 lb)		
	Control and distribution panel	18 kg (40 lb)		
	Distribution panel	18 kg (40 lb)		
	Rectifier shelf	13.6 kg (30 lb)		
	Empty cabinet	152.3 kg (355 lb)		
	Full cabinet	221.4 kg (487 lb)		
	Floor loading, fully loaded (no batteries):	451.8 kg/m ² (92.85 lb/ft ²)		
	Point loading, fully loaded (no batteries):	451.8 kg/m ² (92.85 lb/ft ²)		
Miscellaneous specifications	Heat dissipation	380 watts, or 1300 BTU per hour, per rectifier		
	Mean time between failures (MTBF) of each rectifier	>120,000 hours, per Bellcore standards		

Table 11
MPP600 specifications (Part 3 of 3)

Specification	Characteristic	Min	Nominal	Max
Standards compliance	Standard: ANSI Std C62.41/IEEE standard 587-1980, Class A and B lightning surge Specification: 6000 volts, 3000 amps, 1.2 x 50 μ s impulse, 10 hits per second			
	Standard: ANSI Std C62.41 oscillatory surge Specification: 2500 volts, 0.5 μ s impulse, 100 kHz positive/negative oscillating decay			
	Standard: Bellcore Std TR-TSY-000947			
	Standard: UL Std 1801			
	Standard: UL Std 1950			
	Standard: CSA Std 22.2 #234 and #225			
	FCC Rules and Regulations, Part 15, Subpart B for class A equipment			
	Standard: CSA Std 108.8 for class A equipment			
	Standard: UL Std 1459 Ed. 2			
	Standard: IEC-950 Std, VDE EN 60950/EN41003 (applies to MPR50 rectifier only)			

System 600/48

The System 600/48 Power Plant is described in detail in *Meridian 1 applications - System 600/48* (167-9021-111).

The System 600/48 Power Plant is a positive ground, -48 V DC, 600-A power plant. It can be used with all Meridian 1 DC-powered systems, but is optimized for larger system configurations such as system options 61C and 81C. Other switchroom equipment that requires -48 V DC power may also be powered from the System 600/48 Power Plant, as long as there are sufficient output circuit breakers or auxiliary fuses, the total load does not exceed 600 A, and a consistent, single-point ground topology is maintained for all associated equipment.

The System 600/48 Power Plant consists of either the NT6C32AD main bay (for loads requiring up to 300 A) or the NT6C32AD main bay and the NT6C32AE supplemental bay (for loads up to 600 A), a front access common equipment panel, one front access controller, one front access circuit breaker panel, and two rectifier shelves that can contain up to six NT5CO7AC rectifiers. Included with the supplemental bay are all DC cables and signal wires to connect the supplemental bay to the main bay. The two bays should be within 20 cable feet from each other.

The System 600/48 Power Plant utilizes up to twelve 50-A switch mode rectifiers (NT5CO7AC) as building blocks connected in parallel to reach the maximum capacity of 600 A. This maximum capacity may be attained without power interruption to the load.

The rectifiers operate on single-phase 50 or 60 hertz AC service from either 208 V or 240 V nominal input. The power system may operate with or without -48 V DC batteries for reserve power. If batteries are connected, the rectifiers can operate in either the float or equalize mode.

The System 600/48 Power Plant is designed with access from the front. All operational controls are accessible from the front of the unit. It is designed for seismic environments to Zone 4 (Bellcore) free standing configurations, with no external bracing required.

The System 600/48 Power Plant has a variety of monitoring and alarm features, such as high and low voltage alarms, fuse and breaker alarms, rectifier failure alarms, and low voltage disconnect. An interface to the NT8D22 System Monitor provides a subset of these alarms.

Equipment applications

System 600/48 Power Plant is designed to power Meridian 1 DC systems that require less than 600A of current capacity. Many existing SL-1 cabinet types are also supported.

WARNING

System 600/48 Power Plant and the NT5C07AC 50A rectifiers are not compatible with the earlier SL-1 and Meridian 1 power rectifiers, such as the NT6D52, QRF 12, QRF8, QRF9, or NT6D82.

Power systems containing these rectifiers cannot be connected in parallel nor attached to the same battery string with the NT5C07AC rectifiers from the System 600/48 Power Plant.

System 600/48 Power Plant is intended for new applications and for upgrade situations where the System 600/48 Power Plant is used to power both the existing and the new communication equipment.

System 600/48 Power Plant may power any equipment that requires -48V power as long as the total current requirement does not exceed 600A and a consistent single point ground topology is maintained for all associated equipment. It is recommended that the auxiliary equipment whose logic and frame grounds are separated be connected to the Meridian 1 and the System 600/48 Power Plant. General grounding information can be found this document and in the following documents:

- *Installation Planning* (553-3001-120)
- *System Installation Procedures* (553-3001-210)

Note: The System 600/48 Power Plant 's NT6C32AE supplemental bay can be used to upgrade the existing MPP600 and QCA13 power systems. To upgrade the MPP600 Power Plant an LVD kit (P0816320) is required. To expand the QPA13 a kit is not required.

Specifications

Selected specifications used for system engineering and site planning are listed in Table 12.

Table 12
System 600/48 specifications (Part 1 of 3)

Specification	Characteristic	Min	Nominal	Max
Input voltage	Voltage (V ac)	176	208 or 240	264
	Frequency (Hz)	47	50 or 60	63
	AC input wiring requires one 25 or 30 A hard-wired AC circuit per NT5C07 rectifier.			
Input Current	Current (A) at input voltage of 208 VAC and -56 VDC for 50A output current.		15	
Input AC Service Recommendation	A 30A two pole circuit breaker for each rectifier at the AC service panel. If two individual circuit breakers are used side-by-side, they should also be rated at 30A and 250V. Refer to <i>Installation Planning</i> (553-3001-120) for the AC service panel requirements.			
Input protection	A two pole circuit breaker for each rectifier input to break both input lines for 208/240 VAC, 20A service.			
Output voltage	Float (V DC)	46	54.0*	59.5
	Equalize (V DC)	50	55.5	63.5
	Note: Factory set output float voltage is 54 V DC, to accommodate a standard 24-cell battery string of 2.25 volts per cell (typical VRLA batteries).			
Output current rating	System output current is 50 A per NT5C07 rectifier, to a maximum of 600 A with 12 NT5C07 rectifiers in 2 bays.			
Output protection	The output current limiting circuit is set in the factory to limit the output to 52.5A. A single pole 60A circuit breaker is connected in series with the negative output terminal in the rectifier			
Output regulation	Within +/- 0.5% of the set output value for all specified input and output variations. Within +/- 1% including the environmental variations.			
Heat dissipation	4,560 Watts (15,579 Btu/hr) for a fully equipped System 600/48.			

Table 12
System 600/48 specifications (Part 2 of 3)

Specification	Characteristic	Min	Nominal	Max
Mechanical specifications	System 600/48 Power Plant main or supplemental cabinet:	H=1473 mm (58 in.), 1549 mm (61 in) with top hat extension W=610 mm (24 in.) D=381 mm (15 in.)		
Total weight without rectifiers	Main bay: 350 lb (159 kg) Supplemental bay: 260 lb (118 kg)			
Total weight with rectifiers	Main bay: 482lb (219 kg) Supplemental bay: 392 lb (179 kg)			
	CE Panel (NT6C18CB)	18 kg (40 lb)		
	Front access circuit breaker panel (NT6C12FB)	11.3 kg (25 lb)		
	Front access controller (NT6C25FX)	7.5 kg (16.5 lb)		
	Rectifier shelf	15 kg (33 lb)		
	50A Switch Mode Rectifier (NT6C07AC)	10 kg (22 lb)		
	Floor loading, 3.1 N/sq m (64.3 lb/sq in) for the main bay and 2.5 N/sq m (52.2 lb/sq in) for the supplemental bay.			
	Point loading, 18.8 N/sq cm (27.2 lb/sq in) for the main bay and 15.3 N/sq cm (22.1 lb/sq in) for the supplemental bay.			
Miscellaneous specifications	Heat dissipation	380 watts, or 1300 BTU per hour, per rectifier		

Table 12
System 600/48 specifications (Part 3 of 3)

Specification	Characteristic	Min	Nominal	Max
Standards compliance	Standard: ANSI Std C62.41/IEEE standard 587-1980, Class A and B lightning surge Specification: 6000 volts, 3000 amps, 1.2 x 50 μ s impulse, 10 hits per second			
	Standard: ANSI Std C62.41 oscillatory surge Specification: 2500 volts, 0.5 μ s impulse, 100 kHz positive/negative oscillating decay			
	Standard: Bellcore Std TR-TSY-000947			
	Standard: UL Std 1801			
	Standard: UL Std 1950			
	Standard: CSA Std 22.2 #234 and #225			
	FCC Rules and Regulations, Part 15, Subpart B for class A equipment			
	Standard: CSA Std 108.8 for class A equipment			
	Standard: UL Std 1459 Ed. 2			
Standard: IEC-950 Std, VDE EN 60950/EN41003 (applies to NT6C07AC rectifier only)				

Table 13 list the operating and storage temperature, humidity, and altitude. It also lists the storage temperature and humidity and transportation vibration and shock parameters.

Table 13
Environmental specifications

Parameter	Description
Operating temperature	0°C to 50°C (32°F to 122°F)
Operating humidity	0 to 95% (non-condensing)
Operating altitude	Sea level to 2100 m (7000 feet)
Transportation and storage temperature	-50°C to 75°C (-58°F to 167°F)
Transportation and storage humidity	0 to 95% (non-condensing) 4 kPa max. WVP for 10 days
Transportation vibration	TR-EOP-000063 Section 5.4.4 Transportation Vibration of the packaged equipment
Transportation shock	TR-EOP-000063 Section 5.4.1 Handling Drop Tests and TR-NWT-000063 Section 5.4.3 Installation Shop Tests

J2412 Power Plant

The J2412 Power Plant is a complete external power supply which can be used with system options 71, 81, and 81C (and large option 61 and 61C configurations). The power plant consists of the QCA13 main power cabinet which houses up to four rectifiers. Up to two supplemental cabinets can be added, with up to four rectifiers in the first supplemental cabinet and up to two rectifiers in the second cabinet, for a total of 10 rectifiers.

QCA13 cabinet

The QCA13 is the cabinet that houses fusing and distribution components, monitoring and control equipment, and up to four NT5C03 or NT5C07 rectifiers (see Figure 16). The NT5C07 Rectifier is superseding the NT5C03 Rectifiers in QCA13. When using NT5C07 Rectifiers in a QCA13 cabinet, an NT5C12 Modular Power Shelf must be used. Multiple cabinets can be added to house up to ten rectifiers. Table 14 lists the specifications of the QCA13 cabinet.

Table 14
QCA13 specifications

Characteristic	Specification
Physical dimensions	H = 182.9 cm (72 in.) W = 129.5 cm (51 in.) D = 50.8 cm (20 in.)
Weight	590 kg (1300 lbs)
Floor loading	977 kg/m ² (200 lb/ft ²)
Floor bearing	342 kg/m ² (70 lb/ft ²)
Power dissipation	1400 watts

Note: QCA13 is the designation for an empty cabinet, but the total package (the cabinet, the NT5C03 or NT5C07 rectifier, and other equipment housed in the cabinet) is commonly referred to as QCA13. The supplemental cabinets are identical to the main cabinet except that they do not contain the control panel and charge bar panel.

Figure 16
QCA13 Main Power Cabinet Assembly

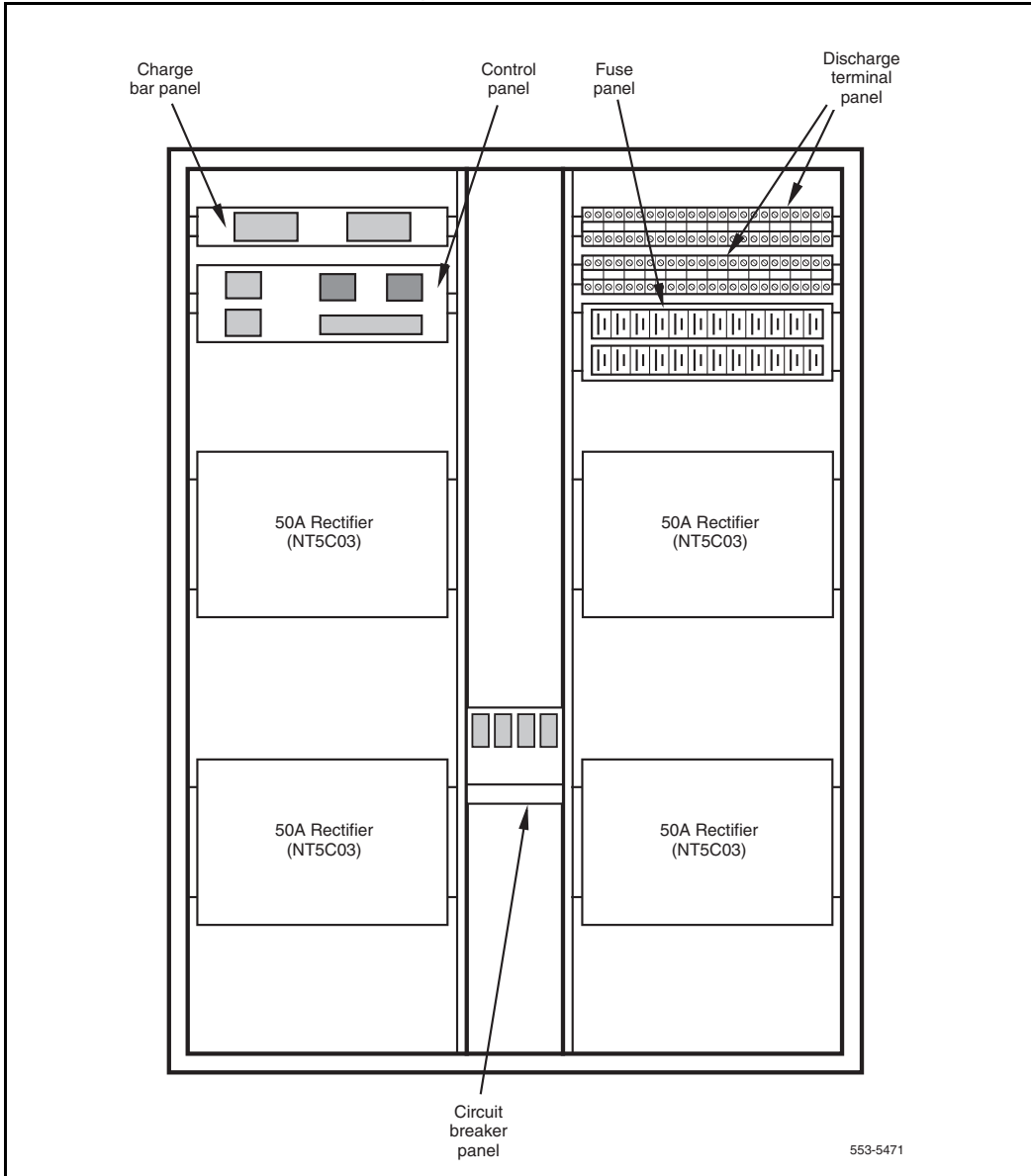

NT5C03 rectifier

The NT5C03 is a switch mode rectifier that converts 208/240 V ac to –48 V DC with a 50 A output. Up to ten rectifiers can be used in parallel for a total system capacity of 500 A. The quantity required is determined by system power consumption. Table 15 contains specifications for the NT5C03.

When wiring the QCA13 cabinets to the commercial utility AC power, you must provide one direct-wired 30 A circuit per rectifier. This circuit consists of #10 AWG conductors connecting to terminals L1 (AC hot conductor), L2 (AC neutral conductor), and FR GND (AC ground) on each rectifier.

NT5C07 rectifier

The NT5C07 is a switch mode rectifier that converts 208/240 V ac to –56 V DC with a 50 A output. Up to ten rectifiers can be used in parallel for a total system capacity of 500 A. The quantity required is determined by system power consumption. Table 10 contains specifications for the NT5C07.

When wiring the QCA13 cabinets to the commercial utility AC power, you must provide one direct-wired 30 A circuit per rectifier. This circuit consists of #10 AWG conductors connecting to terminals L1 (AC hot conductor), L2 (AC neutral conductor), and FR GND (AC ground) on each rectifier.

QBL12 distribution box

The QBL12 Power Distribution Box is a wall-mounted unit that connects customer-provided power equipment to the Meridian 1. A QBL12 can provide up to twenty-four 30 A feeds; the number of feeds actually used will depend upon system configuration and distance from the QBL12 to the Meridian 1. The total allowable load current is 600 A. Generally, one power distribution box is required per system (see Figure 17 on page 72). The QBL12 can be used with system options 71, 81, 81C and large option 61 and 61C configurations.

The QBL12 measures 66 cm (26 in.) high, 61 cm (24 in.) wide, and 19 cm (7.5 in.) deep, and weighs approximately 22.7 kg (50 lb)

Note: The battery positive is typically connected to a ground window connected to the ground bus in the AC power service panel. This ground window serves as the –48 V return and LRE of the installed system.

Table 15 provides input, output, environmental, physical, and EMI specification for the NT5C03 rectifier.

Table 15
NT5C03 rectifier specifications (Part 1 of 2)

Input voltage	183 to 264 V ac, 230 V nominal, single phase, 47–63 Hz
Input current	23 A at 208 V 21 A at 230 V
Output voltage	Nominal –52 V, maximum –56 V, adjustable from –47 to –56 V DC in float and equalize modes.
Regulation	1%
Input protection	30 A, 2-pole circuit breaker
Output protection	Current protection: 60 A circuit breaker Thermal protection: turnoff at 103°C, automatic restart <73°C) High voltage shutdown: adjustable from –53 to –62 V Low voltage shutdown: adjustable from –42 to –58 V
Alarm range	High voltage alarm: adjustable from –48 to –61 V
Output noise and ripple	Less than 25 mV rms Less than 22 dBrnC Less than 200 mV peak-to-peak
Efficiency	87% at a nominal voltage of 230 V at maximum load (30 to 50 A)
Power factor	0.7 at nominal voltages and maximum load
Electromagnetic Interference (EMI)	Meets FCC requirements for conducted and radiated EMI as specified in Docket No. 20780 (April 9/80) for Class “A” equipment
Physical characteristics	Height: 22.9 cm (9 in.) Width: 48.3 cm (19 in.) Depth: 38.1 cm (15 in.) Weight: 38.5 kg (85 lb)
Operating conditions	Temperature: 0 to 50°C (32 to 122°F) Humidity: 15 to 80% RH Altitude: Sea level to 2100 m (7000 ft)

Table 15
NT5C03 rectifier specifications (Part 2 of 2)

Transport conditions	Temperature: -50 to 71°C (-58 to 160°F) Humidity: Up to 100% RH at 25 mm of water vapor pressure Vibration: 5.5 to 500 Hz, 3.5 g maximum (sinusoidal); 762 mm (30in.) maximum drop (packaged) Pressure: 87.5 mm Hg at 15,200 m (50,000 ft) Temperature shock: -50 to 27°C (-58 to 80°F) in 5 minutes
Storage	Temperature: -40 to 60°C (-40 to 140°F) Humidity: Up to 100% RH at 25 mm of water vapor pressure

Figure 17
QBL12 Power Distribution Box

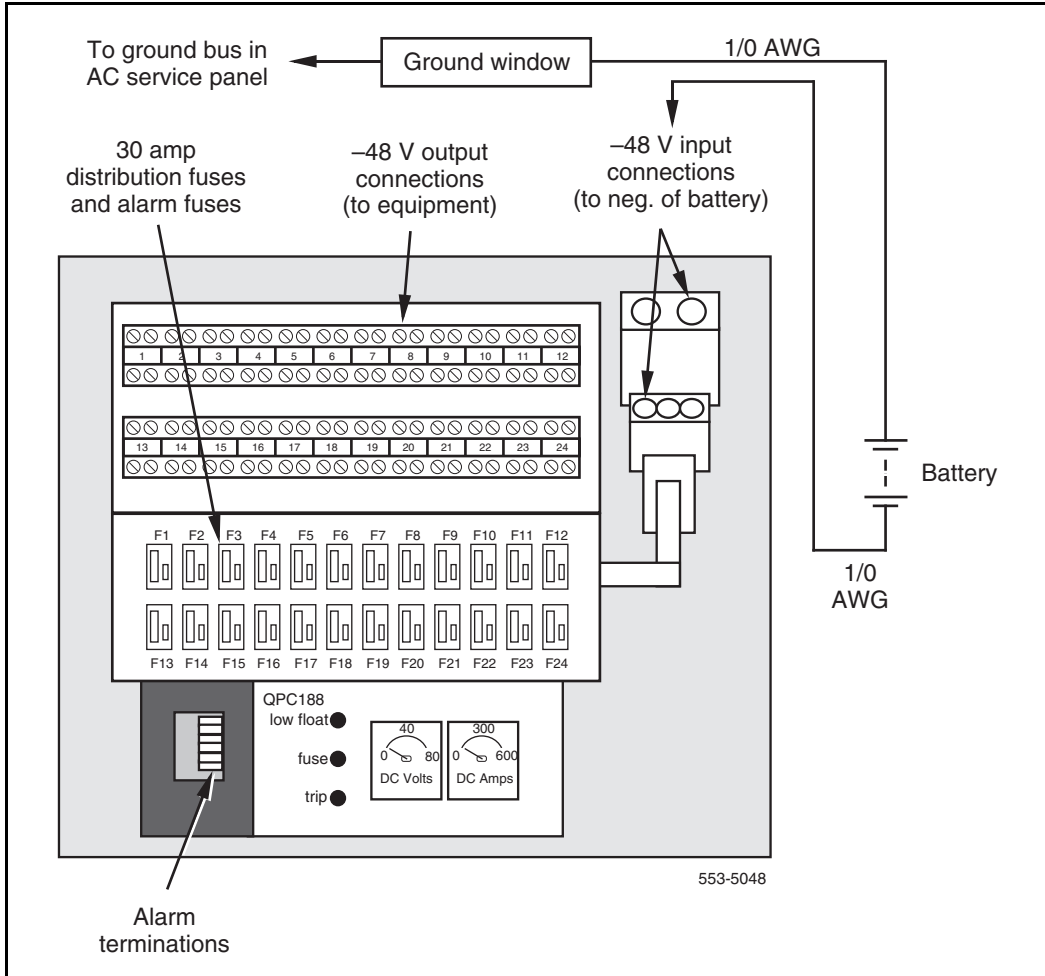

NT6D82 Power System

The NT6D82 Power System is a positive ground, -48 V DC, 900 A power plant. It can be used with all Meridian 1 DC-powered systems, but it is optimized for larger system configurations such as system Options 81, and 81C. Other switchroom equipment that requires -48 V DC power may also be powered from the NT6D82 Power System, as long as there are sufficient output circuit breakers or auxiliary fuses, and a consistent, single-point ground topology is maintained for all associated equipment. For new installation, System 600/48 Power Plant should be used instead of NT6D82.

Figure 18 shows the NT6D82 Power System, which consists of an enclosed, front-access power distribution and control panel, mounted on a standard 23-in. relay rack, with wiring and provision for up to three RL100F50 rectifiers per rack. These rectifiers provide 100 A each for a total of 300 A in a single rack and up to 900 A total in a maximum configuration of three fully equipped racks.

The NT6D82 Power System is organized into power bays. The main power bay contains both the control and distribution circuitry; the supplemental bay contains only the distribution elements and operates somewhat as a “slave” to the main bay. Each system has one main power bay and may have up to two supplemental power bays.

Two kinds of power bays are available: standard power bays, which use conventional power equipment racks; and seismic power bays, which use specially designed racks that have been strengthened for earthquake bracing.

The rectifiers operate on single-phase 60 Hz AC service, and may be strapped for 120, 208, or 240 V nominal input. The NT6D82 Power System may operate with or without a battery bank for reserve power capabilities. If a battery bank is connected, the rectifiers can operate in either float or equalize mode.

The system has a variety of monitoring and alarm features, such as high and low voltage alarms, fuse and breaker alarms, rectifier failure alarms, and low voltage disconnect. An interface to the NT8D22 System Monitor provides a subset of these alarms.

Figure 18
NT6D82 power bay configuration with three RL100F50 rectifiers

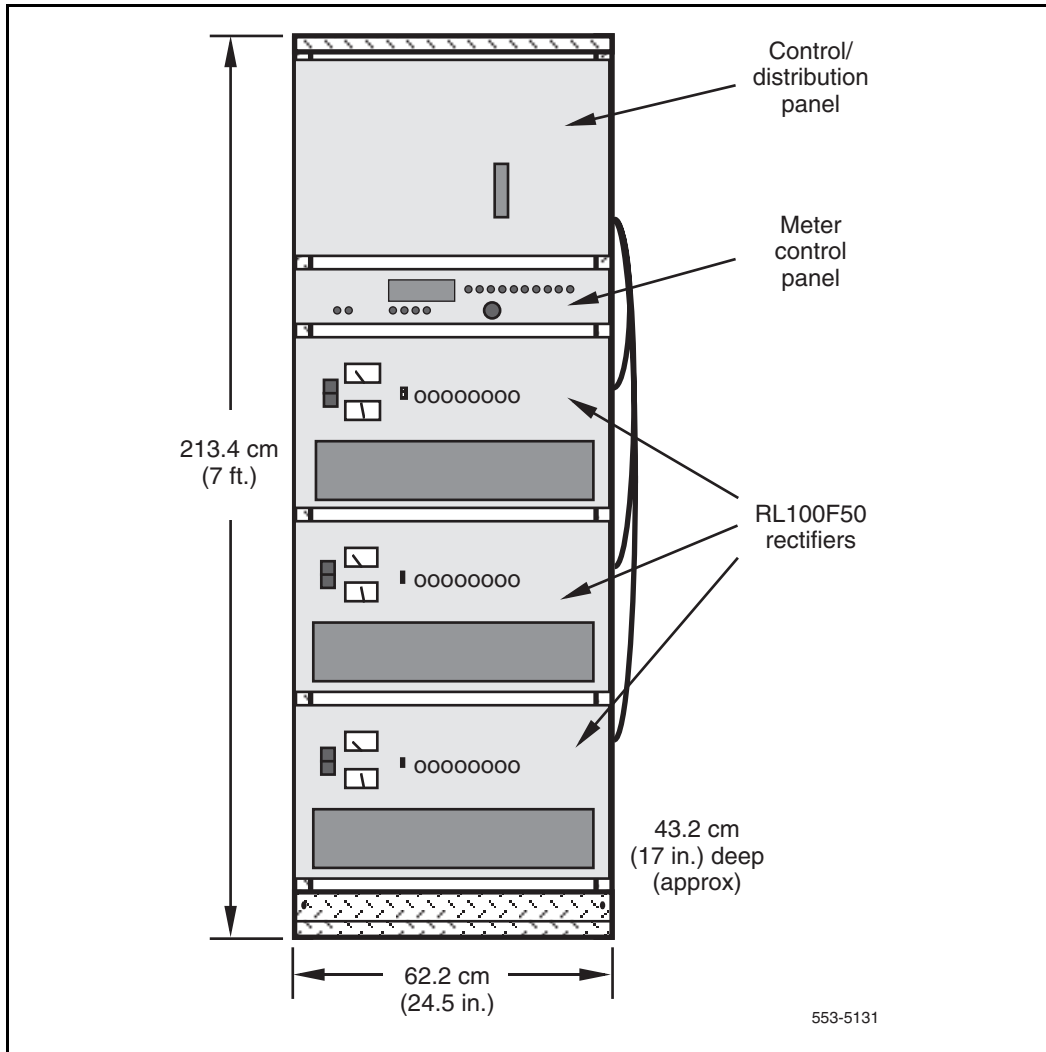

A single-pole, 125 A circuit breaker is connected in series with the rectifier negative output lead for short-circuit protection.

Specifications

The NT6D82 Power System operates within the specifications provided in Table 16.

Table 16
NT6D82 Power System specifications (Part 1 of 2)

Input voltage	Nominal 120/208/240 V (strapping option), single phase, 57–63 Hz. Voltage ranges are 106 to 127 V, 184 to 220 V, and 212 to 254 V
Input current	37.8 A maximum at 208 V 32.7 A maximum at 240 V
AC input current	At 208 or 240 V, use 45 A (minimum) hard-wired circuit. High in-rush circuit breakers or slow-blow fuses are recommended.
Output float voltage	The float voltage is adjustable over the range of –48 to –58 V for floating a 23- or 24-cell battery. The float voltage range per cell is 2.15 to 2.25 V. Factory set value is –54.00 V.
Output equalize voltage	The equalize voltage is adjustable over the range of –50 to –58 V for equalizing the charge on a 23- or 24-cell battery. The equalize voltage range per cell is 2.20 to 2.35 V. Factory set value is –55.50 V.
Output current, max	900 A, full configuration, full load
Input protection	A two-pole circuit breaker opens both AC input lines for 208/240 V service or one side for 120 V operation.
DC current output protection	A limiting circuit is provided for each rectifier output for protection against damage from overloads. This circuit is factory set to limit output current to 110% of full load.

Table 16
NT6D82 Power System specifications (Part 2 of 2)

Storage temperature range	-40 to 85°C (-40 to 185°F)
Humidity	0 to 95%, non-condensing
Altitude	The maximum ambient operating temperature should be derated linearly from 50°C at sea level to 40°C at an elevation of 3050 m (10,000 ft).
Dimensions: (all bays)	Height: 213 cm (84 in.) Width: 62 cm (24.5 in.) Depth: 43 cm (17 in.)
	With diode panel, depth increases to 65 cm (25.5 in.).
Weight	Main or supplemental bay with three rectifiers: 544 kg (1200 lb)
	Single rectifier: 133 kg (292 lb)
	Diode panel: 9 kg (20 lb)
Heat dissipation	With 208 V ac input and 52.08 V DC output at full load, the heat dissipation of each rectifier is 580 watts (1980 BTU/hour).
Reliability	MTBF for the rectifier is 52,000 hours.

External DC power configurations

Figures 19 through 25 show examples of DC-powered system power and ground connections. There are many variations of the rectifier and distribution equipment. The following information applies to Figures 19 through 25.

If rectifiers are direct-wired to the local utility supply, conduit may be used. If conduit is used, it must contain an insulated ground wire (green) #6 AWG or larger.

Conduit is not necessary with the NT7D67CB PDU. However, 1.25 in. or 0.75 in. conduit may be used if local codes or individual installations require it. For overhead conduit installation, a conduit clamp may be used. For a raised-floor installation, the conduit should terminate at the floor. If the NT7D0902 Conduit Kit is used, conduit can enter from the rear of the system (above the floor).

Grounding considerations

As with all high current systems, good grounding is essential for proper equipment function. Be sure to review the section titled “Grounding” on page 16.

In Nortel Networks external DC-powered systems the common ground (+) bus bar in the DC distribution panel serves as both the battery return and logic return equalizers (BRE and LRE). Use a #6 AWG conductor to connect this bus to the ACEG.

If cord-and-plug wiring is used to power the rectifiers, a separate safety ground must be provided. The safety ground must be an insulated wire #6 AWG or larger. Figures 19 through 25 show an isolated ACEG as the single-point ground. Depending on the distance between columns (and cabinets in upgraded systems) and the service panel, the Meridian 1 safety ground wiring may be daisy-chained or run independently from each column (or each row) to the ACEG. Figures 19 through 25 show safety ground wiring in daisy-chain configurations.

Figure 19
DC power—multiple-column distribution with MFA150 Modular Power System

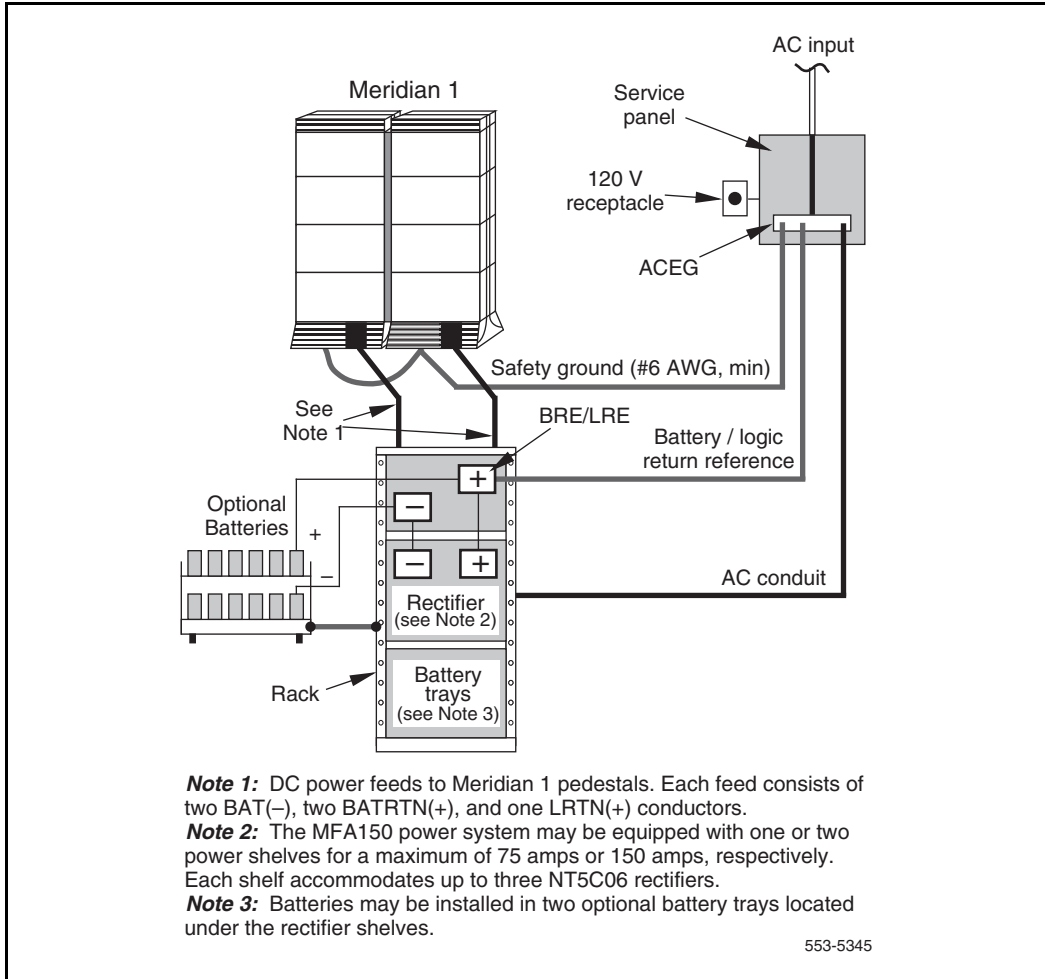

Figure 20
DC power—multiple-column distribution with System 600/48 Power Plant

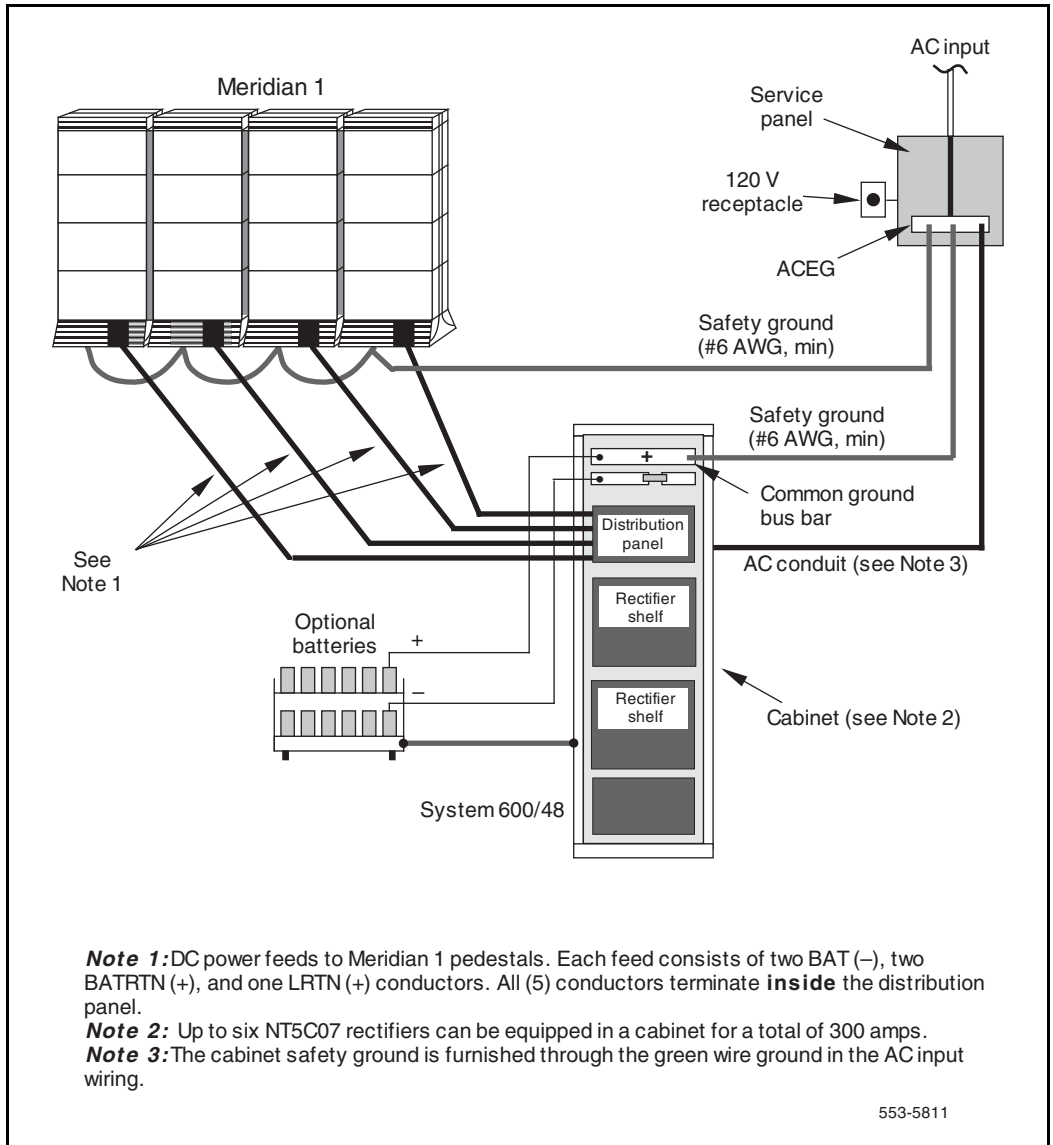

Figure 21
DC power—multiple-column distribution with NT6D82 Power System

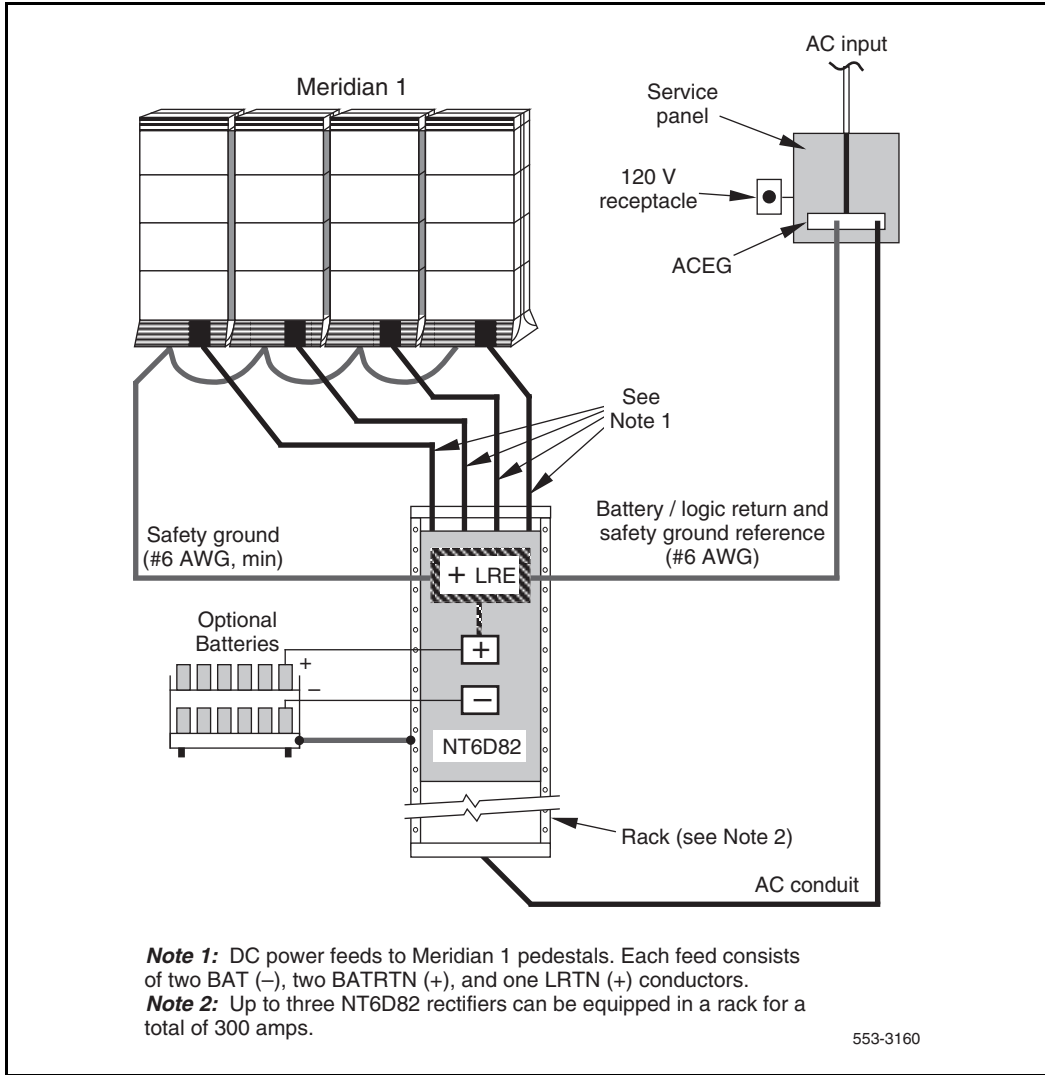

Figure 22
DC power—multiple-column distribution with QBL12 and customer power

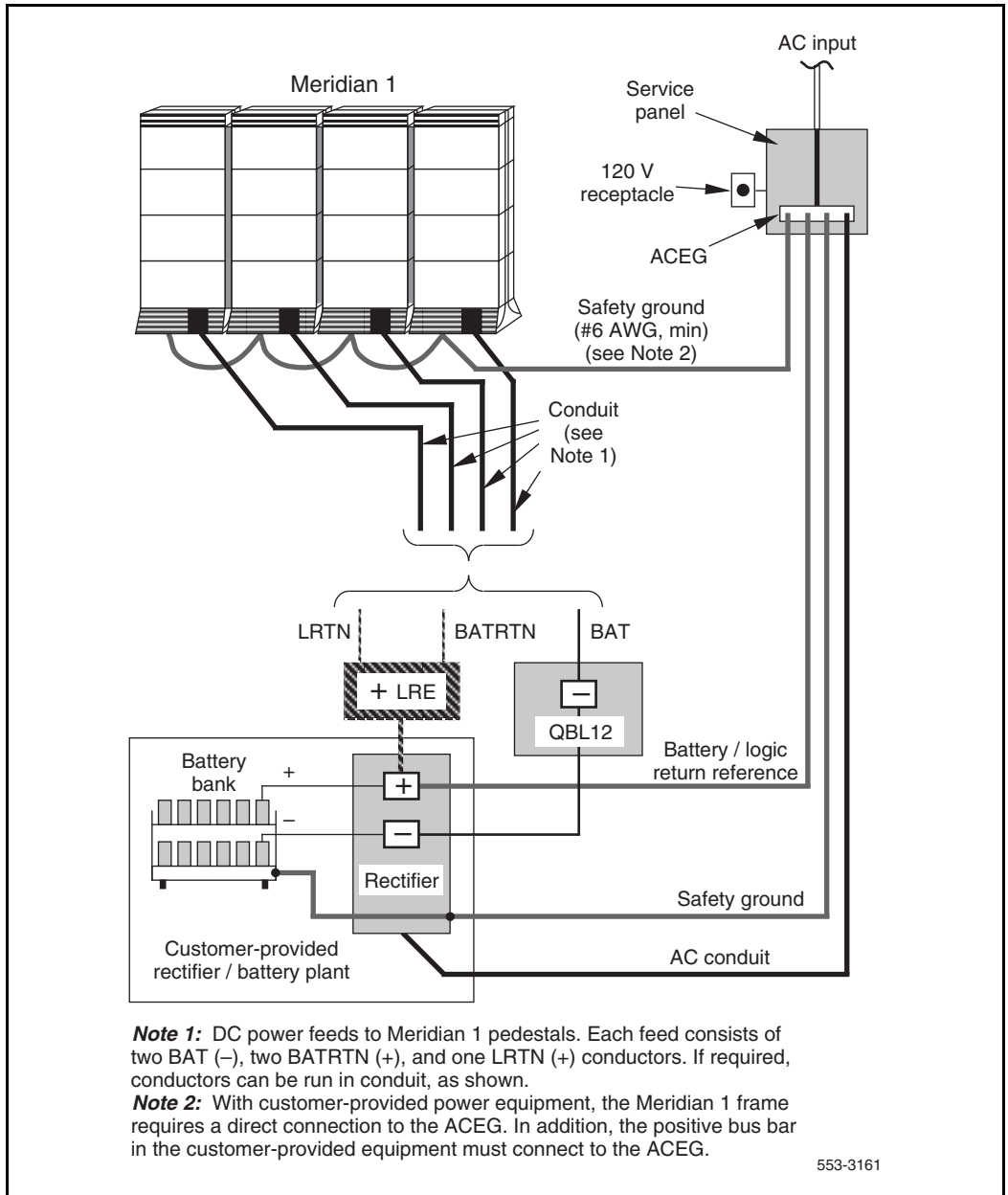
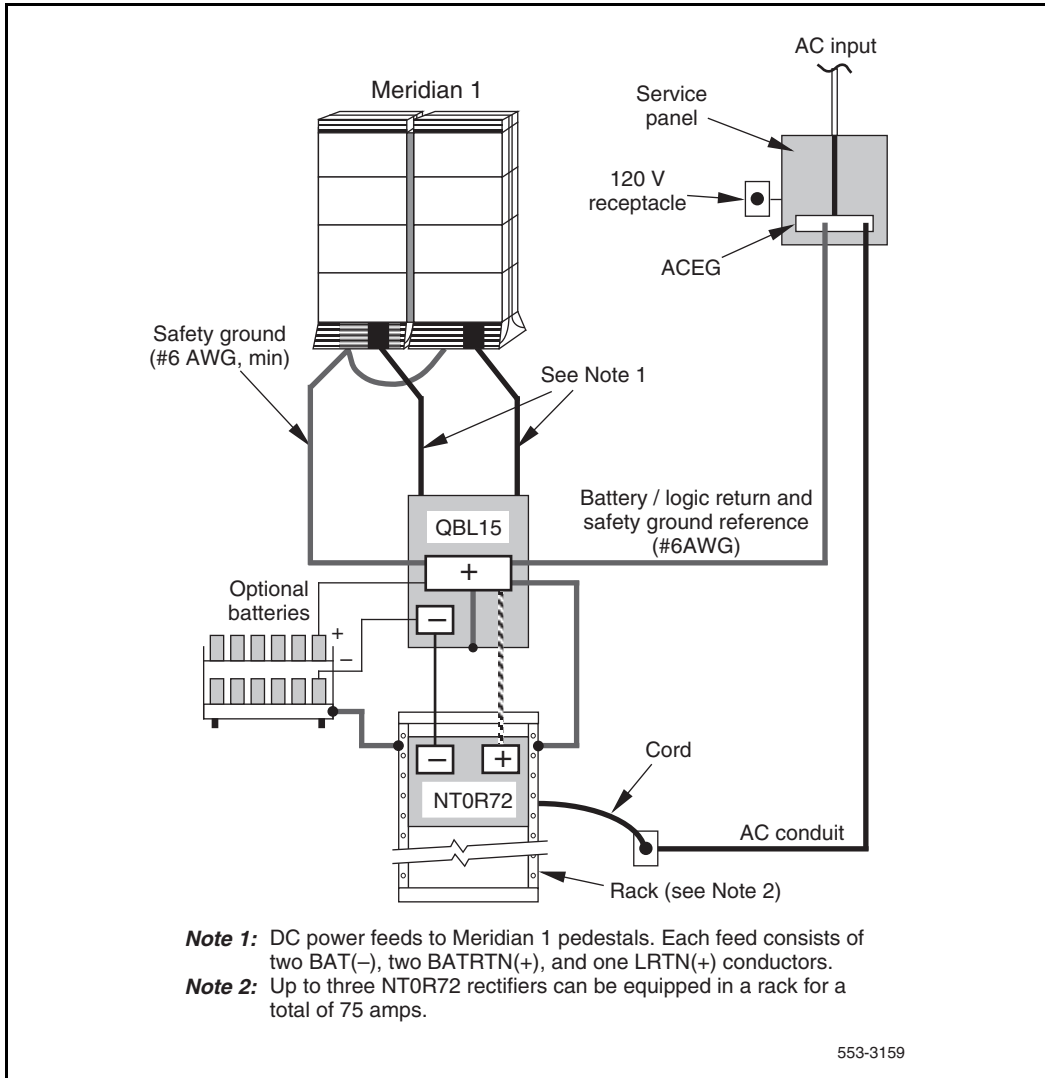

Figure 23
DC power—multiple-column distribution with NT0R72 rectifier and
QBL15 Power Distribution Box



- Note 1:** DC power feeds to Meridian 1 pedestals. Each feed consists of two BAT(-), two BATRTN(+), and one LRTN(+) conductors.
- Note 2:** Up to three NT0R72 rectifiers can be equipped in a rack for a total of 75 amps.

553-3159

Figure 24
DC power—multiple-column distribution with J2412 Power Plant

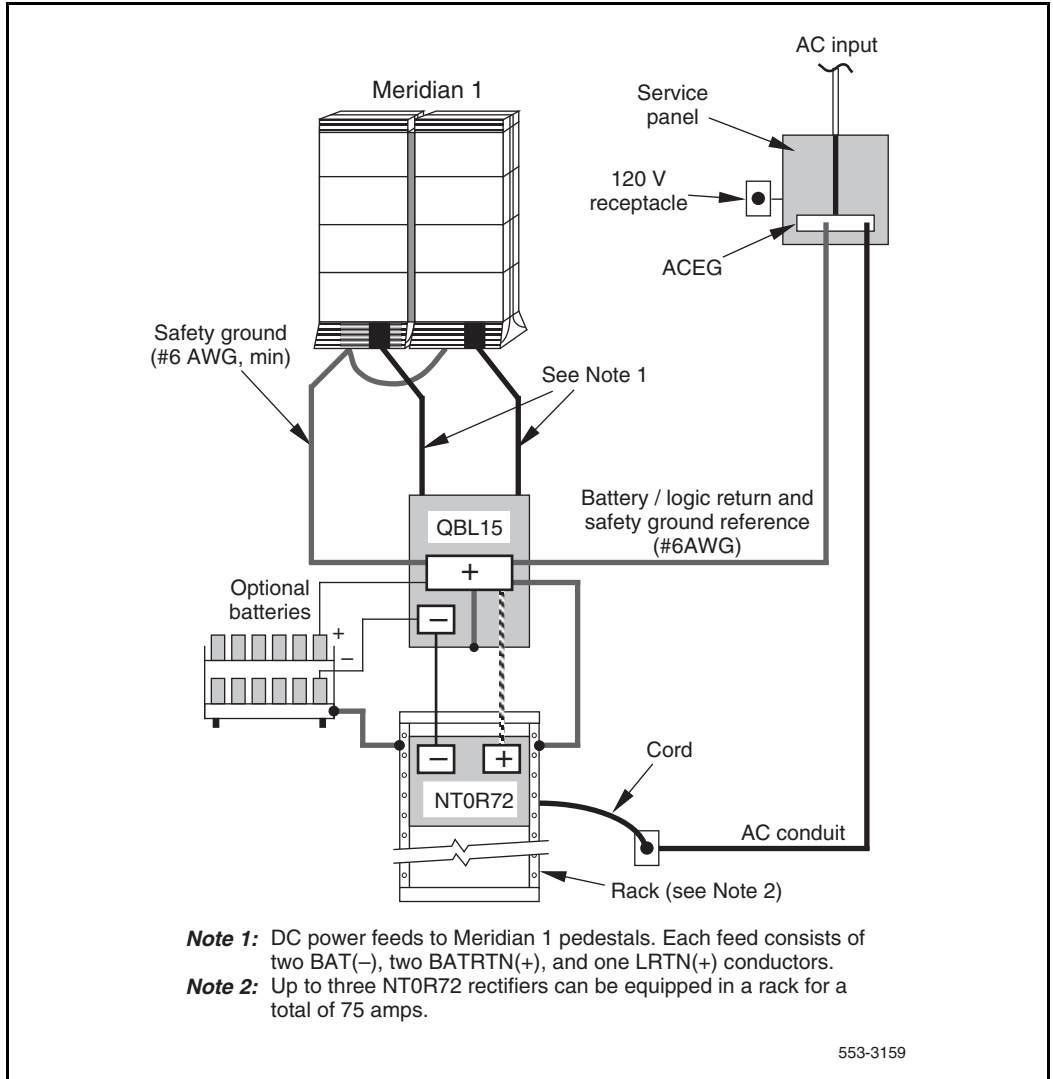
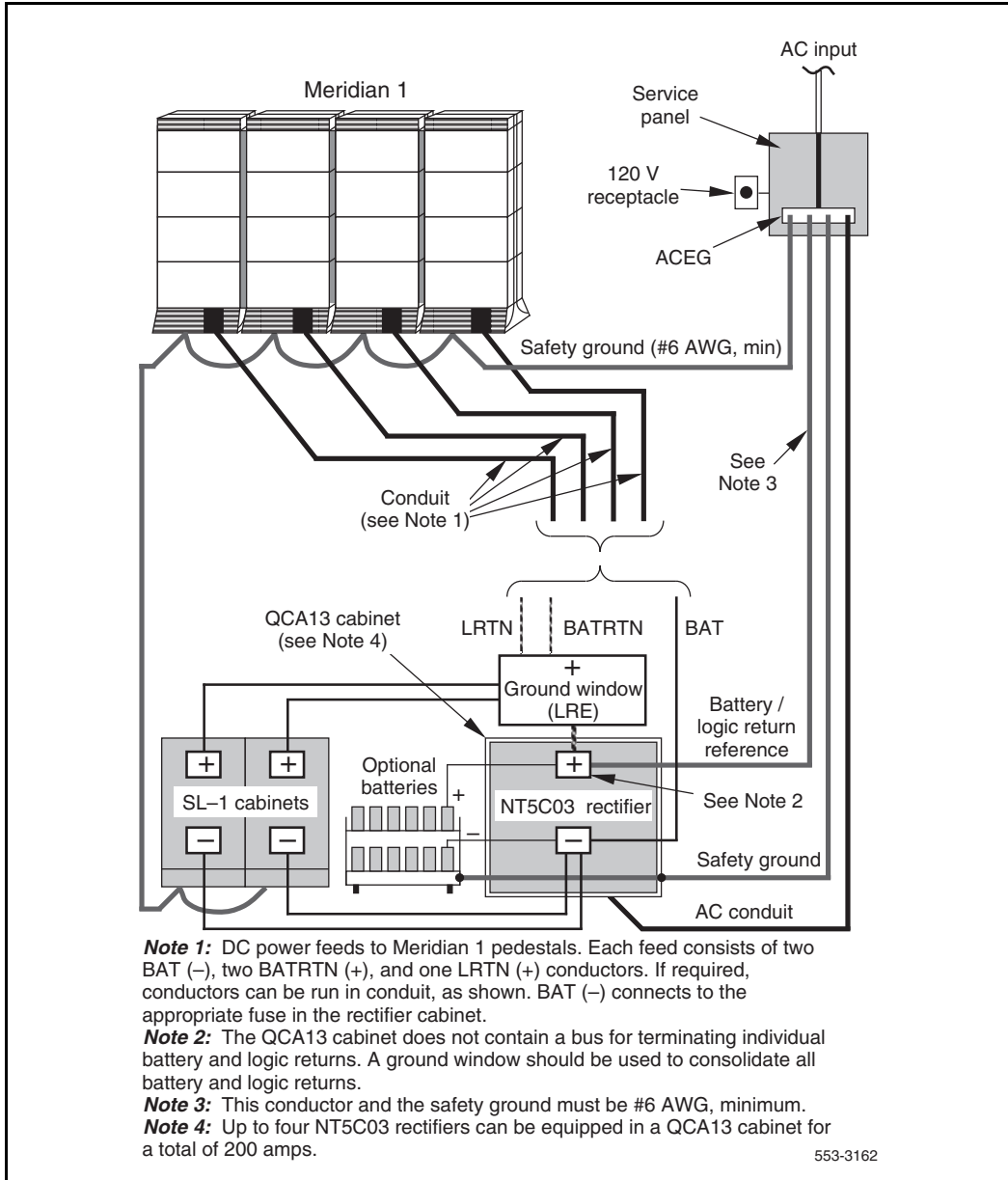

Figure 25
DC power—example of upgraded system distribution



Component power consumption

Contents

This section contains information on the following topics:

Introduction	85
Reference list	85
Power calculation guidelines	89
Meridian 1 upgrades	92
Powering upgraded systems from existing rectifiers	92

Reference list

The following are the references in this section:

- *Hardware Upgrade Procedures (553-3001-258)*

Introduction

Before you can calculate the total power consumption of your Meridian 1 configuration, you must have consumption figures for each component within the system.

The power consumption of intelligent peripheral equipment (IPE) and peripheral equipment (PE) circuit cards is given in Tables 17 and 18. Because electrical load varies depending on traffic load, some assumptions are made when presenting these figures: 25% of maximum capacity (9 CCS) for digital and analog lines, and 75% of maximum capacity (30 CCS) for trunks. These figures also take into account the average efficiency of the module power supplies.

Table 17
Power consumption—IPE cards

Circuit card	Typical power (watts)
NT5K02 Flexible Analog Line card	20
NT5K17 Direct Dialing Inward Card	29
NT5K17 Direct Dialing Inward Card	29
NT5K19 DC5/AC15/RAN/Paging Trunk Card	29
NT1P62 Fibre Controller Card	26
NT7R52 Remote Carrier Interface	26
NT8D01AC Controller Card-4	26
NT8D01BC Controller Card-4 (SMT)	26
NT8D01AD Controller Card-2	26
NT8D02 Digital Line Card	20
NT8D03 Analog Line Card	16
NT8D09 Analog Message Waiting Line Card	16
NT8D14 Universal Trunk Card	28
NT8D15 E&M Trunk Card	26
NT8D16 Digitone Receiver Card	6

Table 18
Power consumption—PE cards

Circuit card	Typical power (watts)
QPC71 E&M/DX Signaling and Paging Trunk Card	2.5
QPC192 Off-Premises Extension Line Card	12.0
QPC250 Release Line Trunk Card	2.5

Table 18
Power consumption—PE cards

Circuit card	Typical power (watts)
QPC297 Attendant Console Monitor Card	7.1
QPC422 Tone Detector Card	10.9
QPC430 Asynchronous Interface Line Card	14.8
QPC432 4-Port Data Line Card	10.2
QPC449 Loop Signaling Trunk Card	15.6
QPC450 CO/FX/WATS Trunk Card	7.0
QPC578 Integrated Services Digital Line Card	24.6
QPC594 16-Port 500/2500 Line Card	32.8
QPC659 Dual Loop Peripheral Buffer Card	40.4
QPC723 RS-232 4-Port Interface Line Card	14.8
QPC789 16-Port 500/2500 (Message Waiting) Line Card	26.4

Table 19 shows power consumption data for each fully configured module. Use this data for rectifier and reserve power (battery) calculation.

Table 19
Meridian 1 module power consumption

Module	Power consumption (watts)
NT5D21 Core/Network Module	260
NT5K11 Enhanced Existing Peripheral Equipment (EEPE) Module	375
NT6D39 CPU/Network Module	360
NT6D44 Meridian Mail Module	240
NT6D60 Core Module	260
NT8D11 CE/PE Module	500
NT8D13 PE Module	240
NT8D34 CPU Module	260
NT8D35 Network Module	240
NT8D36 InterGroup Module	0
NT8D37 IPE Module	460
NT8D47 RPE Module: — local site	175
— remote site	100
NT9D11 Core/Network Module	260
Application Equipment Module — single	210
— dual	420
Pedestal (with blower unit)	50

System power is calculated by adding the power consumption (in watts) of all equipped modules.

BTU (thermal load) = total power dissipation x 3.41

For air conditioning purposes, 1 ton = 1200 BTU.

Power calculation guidelines

The method for calculating Meridian 1 system power is based on the number of modules and columns in the system, regardless of how many cards are initially equipped. The method ensures that the external power supply provides adequate capacity, under all conditions and all possible growth scenarios, for the modules installed.

Using a system power consumption worksheet (Figure 26), enter the quantity of each type of module, multiply by the power consumption per module, and then sum the individual module totals to obtain the total real power consumed by the system.

To calculate the current drain, divide the total real power consumption by the nominal input voltage. This gives the system current drain, or load in amperes. The worksheet shows nominal voltages of 208 (AC) input and 52 (DC) output. To calculate current drain for voltages other than those given in the worksheet, divide the total real power consumption by the desired voltage (such as 240 V AC or 54 V DC).

For calculations normally done for complex or apparent power (such as AC wire and panel size or the UPS rating for AC reserve power), divide the total real power in watts by the system power factor (typically 0.6) to obtain the complex power in volt-amperes (see Figure 26).

If you are upgrading an installed system, you can determine the total power consumption of the installed system in several ways. Two methods are listed below (the first method is more accurate than the second):

- Measure current drain for the complete installation under actual operating conditions over at least a two-week period. Determine peak current drain from these measurements.
- Measure idle (or near idle) current drain for the complete installation. Estimate peak current drain by multiplying the number of idle amperes by 1.5.

When you add or upgrade equipment, use either of these methods to determine existing current drain/power consumption. Use the guidelines in this document to determine the added power consumption.

The existing power plant may have to be replaced or its capacity may have to be increased to accommodate added equipment. Be sure to provide sufficient capacity to accommodate future growth.

Figure 26
Worksheet A—System power consumption worksheet

SYSTEM POWER CONSUMPTION WORKSHEET					
Module	Quantity		Module power consumption	=	Total module power consumption
NT6D39	_____	X	360	=	_____
NT6D44	_____	X	240	=	_____
NT6D60	_____	X	260	=	_____
NT8D11	_____	X	500	=	_____
NT8D13	_____	X	240	=	_____
NT8D34	_____	X	260	=	_____
NT8D35	_____	X	240	=	_____
NT8D37	_____	X	340	=	_____
NT8D47	_____	X	175	=	_____
Pedestals	_____	X	50	=	_____
Total real power (watts)				=	_____

Current drain:

AC system:

$$\frac{\text{(total real power)}}{\text{(nominal AC voltage)} \quad 208} = \text{_____ amperes, AC}$$

DC system:

$$\frac{\text{(total real power)}}{\text{(nominal AC voltage)} \quad 52} = \text{_____ amperes, DC}$$

Comple (or apparent power) (AC only):

$$\frac{\text{(total real power)}}{\text{(power factor)} \quad 0.6} = \text{_____ volt-amperes (VA)}$$

553-5833

Meridian 1 upgrades

Both AC- and DC-powered Meridian 1 upgrade packages are available, although most of the module-level upgrades will be DC. However, the following suggestions are offered:

- Consider an AC Meridian 1 upgrade if the existing Meridian SL-1 system is not using reserve power. If reserve power is later desired, one or more UPS units can be added.
- If the existing system already has battery backup, or if there is an existing DC power plant or excess rectifier capacity, a DC Meridian 1 upgrade package is usually chosen. For DC upgrades, there are several approaches to system powering:
 - Internal rectifiers that power the existing SL-1 equipment may, in some cases, be connected in parallel to new external rectifiers in order to share a common battery string. The QBL15 Power Distribution Unit is typically used as an interface between the different power equipment.
 - An existing external DC power plant, such as the QCA13, may be used as is, or expanded if necessary, to power both the existing equipment and the new Meridian 1 equipment.
 - A new external DC power plant, such as the NT6D82, the MFA150, or the 600/48 may be purchased and installed to power both the existing and new equipment.

Note: For all DC upgrades, carefully measure or calculate the system load of all equipment to make sure that the chosen power system will have enough capacity.

Consider each upgrade case individually, taking into account the existing equipment, space available at the site, and customer preferences.

Powering upgraded systems from existing rectifiers

Upgrades are available in shelf, cabinet, and module configurations. A shelf upgrade uses the power supplied by the cabinet into which it is installed. Cabinet and module upgrades where some or all of the existing cabinetry is retained can be complex. The addition of one or more modules to the existing system requires careful planning.

In systems where rectifiers are mounted in the equipment cabinets, one or more rectifiers may be added to a rectifier rack to expand the existing power capacity of the system. In centralized power systems in a power cabinet or bay, rectifiers and additional power cabinets or bays may be added as required. If batteries are part of the upgraded system or a centralized power scheme is to be used, rectifier compatibility must be considered. This is due to the fact that rectifiers are connected in parallel through connections made at the QBL15 Battery Distribution Box and centralized power systems; the output voltages of the rectifiers must be balanced for proper load sharing across the entire system.

For detailed information on Meridian 1 upgrades, refer to the *Hardware Upgrade Procedures* (553-3001-258).

Use Table 20 to determine rectifier compatibility for the rectifier types making up the upgraded or expanded system. In the table matrix, “Yes” indicates which rectifier combinations are compatible for load sharing.

Table 20
Rectifier compatibility (Part 1 of 2)

Rectifier type and output current	QRF4	QRF8D (min vintage)	QRF9	QRF12	NT6D52AA	NT0R71	NT0R72	NT5C03 (QCA13)	J2357 (QCA13)	J2427	A03544950 (NT6D82)	NT5C06 (MFA150)	NT5C07 (600/48)
Amps	25	40	20	30	30	25	25	50	50	25	100	25	50
QSD4	Yes												
QRF8D (min. vint.)		Yes		Yes		Yes							
QRF9			Yes										
QRF12		Yes		Yes		Yes							
NT6D52AA							Yes						
NT0R71		Yes		Yes		Yes							
NT0R72		Yes			Yes		Yes						

Table 20
Rectifier compatibility (Part 2 of 2)

Rectifier type and output current	QRF4	QRF8D (min vintage)	QRF9	QRF12	NT6D52AA	NT0R71	NT0R72	NT5C03 (QCA13)	J2357 (QCA13)	J2427	A03544950 (NT6D82)	NT5C06 (MFA150)	NT5C07 (600/48)
Amps	25	40	20	30	30	25	25	50	50	25	100	25	50
NT5C03 (QCA13)								Yes	Yes				Yes
J2357 (QCA13)								Yes	Yes				Yes
J2427										Yes			
A0344950 (NT6D82)											Yes		
NT5C06 (MFA150)												Yes	
NT5C07 (600/48)								Yes	Yes				Yes
<p>Note: Load sharing is possible among rectifiers in the QCA13 cabinet if an upgraded List 3 control card is used as follows:</p> <ul style="list-style-type: none"> — Use the P0677283 control card when only NT5C03 (SMR) rectifiers are installed. — Use the P0562926 control card when both J2357 and NT5C03 rectifiers are installed. 													

Selecting proper wire size

Contents

This section contains information on the following topics:

Introduction	97
Typical wire values	98
Metric conversion	100
Sense lead wire size	100
Calculating wire size	101
Input wire size	102

Introduction

This section provides guidelines for determining wire gauges to connect a pedestal to a rectifier, DC distribution panel, or other external power equipment.

Typical wire values

Table 21 lists typical wire sizes in AWG and circular mils for a given maximum current. Table 22 lists maximum allowable voltage drops for DC power system conductors.

Table 21
Wire characteristics

Wire gauge (AWG)	Circular mils	Maximum amperes
4	41,750	90
6	26,250	65
8	16,510	50
10	10,380	35
12	6,530	25

Note 1: Maximum amperage is affected by many factors, including temperature and insulation. Consult a wire handbook for precise tables.

Note 2: Although gauges smaller than 8 AWG are shown in this table for reference, it is not recommended that sizes smaller than 8 AWG be used for any of the conductors listed in Table 22.

Table 22
Maximum allowable voltage drops

Conductor	From	To	Allowable Voltage drop (max)
- Battery	Pedestal	- Distribution discharge	1.00
+ Battery return	Pedestal	+ Distribution ground	1.00
- Battery	Distribution	- Battery terminal	0.25
+ Battery return	Distribution	+ Battery terminal	0.25

Note: "Distribution" means the DC power distribution panel (box).

Table 22
Maximum allowable voltage drops

Conductor	From	To	Allowable Voltage drop (max)
- Battery	Rectifier	- Distribution charge	0.50
+ Battery return	Rectifier	+ Distribution ground	0.50
Note: "Distribution" means the DC power distribution panel (box).			

Metric conversion

AWG measurements are not directly related to European Industry standard metric measurements. The following table provides guidance when converting from the AWG system to the Metric system for the most commonly used power and ground conductor cables.

Table 23
Metric wire conversion

AWG NO	Industry standard Nominal (Sq mm)	Resistance at 20 deg.C. (Ohm/100m)
2	35	0.05
4	25	0.08
6	16	0.13
8	10	0.20
10	6	0.33
12	4	0.63
14	2.5	1.00
16	1.5	1.40
18	1	2.00
20	0.75	2.90
22	0.5	4.60

Sense lead wire size

When sense leads are required, the loop resistance of the wire used to connect the \pm sense terminals at the rectifiers or DC distribution panel to the \pm terminals of the batteries must not exceed 2.5 ohms.

Calculating wire size

Using the maximum current in a conductor, determine the length that the conductor must be to meet the required maximum voltage drop. When you know the current, distance, and allowable voltage drop for a specific conductor, you can calculate the minimum wire size using the following formula:

$$CM = \frac{11.1 \times I \times D}{V}$$

where

CM = wire size required in circular mils

I = current in amperes (use the maximum expected)

D = distance in feet (to convert meters to feet, divide by 0.3048)

V = maximum allowable voltage drop

CAUTION

Although the voltage drops listed in Table 22 are the maximum drops allowed, the insulation and temperature rating versus current often dictates a wire size that creates smaller voltage drops on short lengths. After using the formula, check the wire tables to make sure the temperature rise is acceptable.

The following examples show wire size calculations using the formula given above:

- Example 1

A battery or battery return conductor from a DC distribution panel to a pedestal is 11.0 m (36 ft.) long and must carry a maximum of 30 A with voltage drop of no more than 1V:

$$CM = \frac{11.1 \times 30 \times 36}{1} = 11,988$$

— Choosing a standard gauge equal to or larger than this requires #8 AWG, which has a cross section of 16,510 circular mils.

- Example 2

A battery or battery return conductor from a DC distribution panel to the battery is 7.6 m (25 ft.) long and must carry a maximum of 35 A:

$$CM = \frac{11.1 \times 35 \times 25}{0.25} = 38,850$$

— Choosing a standard gauge equal to or larger than this requires #4 AWG, which has a cross section of 41,740 circular mils.

Input wire size

Table 24 provides a means for determining the size of wire used to connect the distribution box and the pedestal. A maximum total voltage drop of two volts is allowed between the pedestal and the external power equipment. Table 24 lists cable sizes that give acceptable voltage drops for a given cable length, and those that do not.

Note: Conduit is not necessary with the NT7D67CB PDU.

Table 24
Pedestal wire gauge requirements with two 30 A feeds (five wires)

Length	#8 AWG	#6 AWG	Single #4 AWG	Double #4 AWG
0–3 m (10 ft)	Yes	Yes	Yes	Yes
3–6 m (20 ft)	Yes	Yes	Yes	Yes
6–9 m (30 ft)	Yes	Yes	Yes	Yes
9–12 m (40 ft)	Yes	Yes	Yes	Yes
12–15 m (50 ft)	Yes	Yes	Yes	Yes
15–18 m (60 ft)	No	Yes	Yes	Yes
18–21 m (70 ft)	No	Yes	Yes	Yes
21–24 m (80 ft)	No	Yes	Yes	Yes
24–27 m (90 ft)	No	No	Yes	Yes
27–30 m (100 ft)	No	No	Yes	Yes
30–60 m (200 ft)	No	No	No	Yes
over 60 m (200 ft)	No	No	No	No

Note: Two 30 A feeds are typically adequate for a column with four modules (five wires total—two 30 A feed pairs, BAT(–) and BATRTN(+), plus logic return, LRTN(+)).

Legend: Yes = Wire size is adequate for the distance.
 No = Wire size has too high a voltage drop and is inadequate for the distance.

NT4N49 DC Power Distribution Unit Installation

Contents

The following are topics in this section:

Overview	105
NT4N49 DC power	106
NT4N49 DC PDU preparation	108
NT4N49 DC PDU installation	109
PDU connections	110
Power connection from power plant to NT4N49 DC PDU	115
Connecting Meridian Power DC to the NT4N49 DC PDU	120

Overview

This chapter explains how to install the NT4N49 DC Power Distribution Unit (PDU), install safety ground/protective earth and logic return wiring, configure system monitors, and connect Power Failure Transfer Units (PFTUs) for DC-powered systems using an MFA150, 600/48 power system or Meridian Power DC systems.

Note 1: The procedures in this chapter apply to the global Power Distribution Unit (PDU). Throughout this document, the global PDU is referred to as the “NT4N49 DC PDU.”

Note 2: For information on how to replace a Power Distribution Unit with the NT4N49 DC PDU, refer to “DC Power Distribution Unit Replacement” on page 123.

NT4N49 DC power

All external power and ground sources must be installed on the site prior to Meridian 1 installation.

Turn off all internal and external power switches and breakers:

- Verify that all applicable circuit breakers in the AC main power panel are set to OFF.
- Remove the 30-amp fuse or set the circuit breakers to OFF in the DC power plant.
- Verify that the main circuit breakers in the back of each pedestal are set to OFF.
- Verify that the blowers in each pedestal are switched OFF.
- Verify that the module power supplies are switched OFF.

Figure 27
External DC power and ground wiring

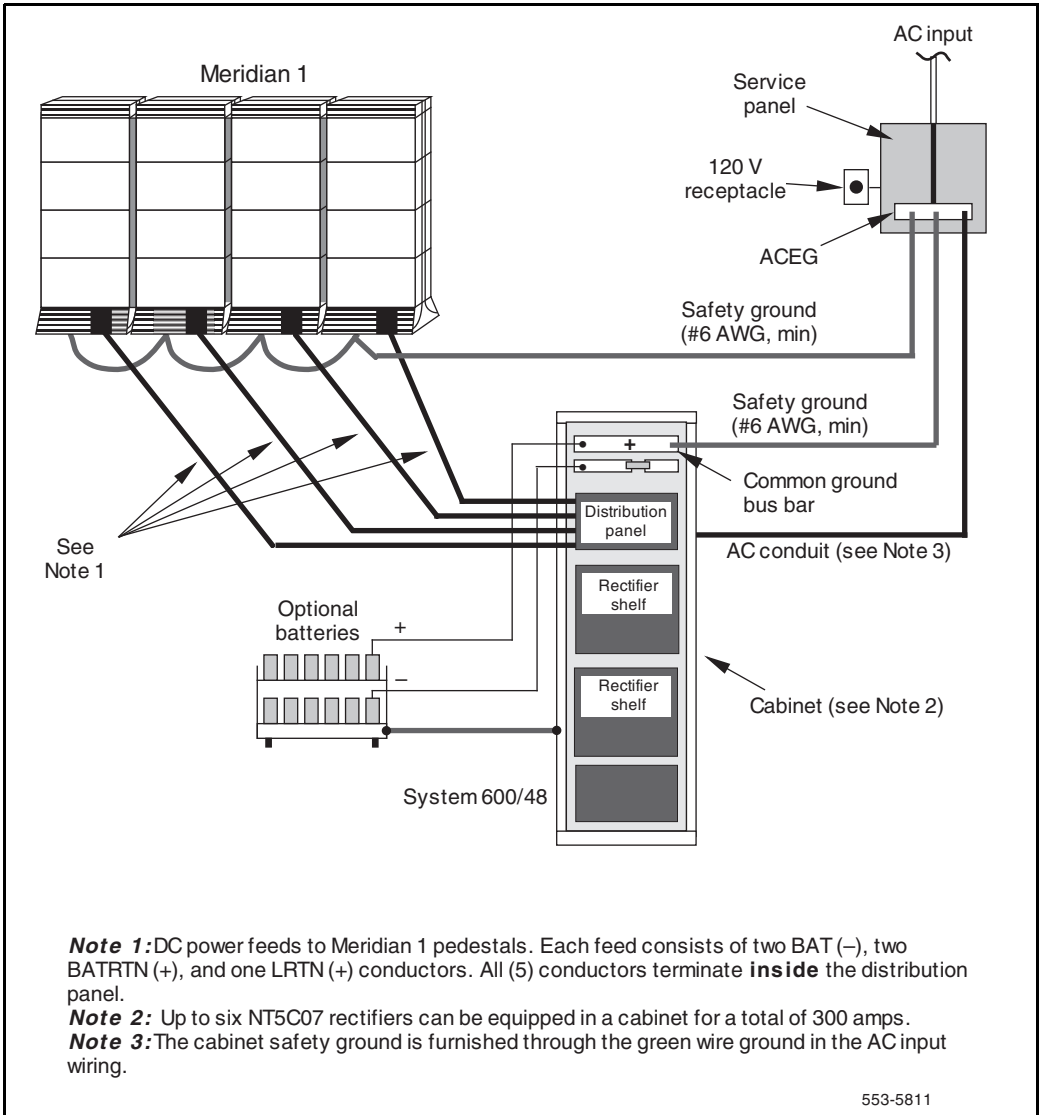

NT4N49 DC PDU preparation

When a Meridian 1 system is shipped, a set of screws secures the leveling bracket at the rear of the NT4N49 DC PDU to protect it from vibration damage during transit. The shipping screws should be removed during initial installation.

Procedure 1

Remove shipping screws

- 1 For access to the rear of the PDU, temporarily remove the blower unit in the front of the pedestal as follows:
 - a Turn the screws on the front of the blower unit counterclockwise.
 - b Grasp the lip at the top edge of the blower unit. Slide the unit out of the glides and onto the bottom ledge of the pedestal. Lift the unit out of the pedestal. (Keep the blower unit in an upright position.)
- 2 Remove the two shipping screws holding the PDU to the vertical shield in the pedestal.
- 3 Reinstall the blower unit as follows:
 - a Set the blower unit on the bottom ledge of the pedestal.
 - b Tilt the back of the blower unit up slightly so it will slide into the pedestal glides (you may need to lift the unit). Gently push the unit into position.
 - c Tighten the screws on the front of the blower unit.

————— *End of Procedure* —————

NT4N49 DC PDU installation

The following steps describe how to install the NT4N49 DC Power Distribution Unit. See Figure 32 on page 115 for an illustration of the unit.

Procedure 2

Install the NT4N49 DC PDU

- 1 Remove fan blower located behind pedestal.
- 2 Push the power cable through the pedestal. This power cable will connect to the external individual shelves.
- 3 Attach the (green) ground wire to the back of the pedestal.
- 4 Attach the monitoring cables to the XSM ribbon connector.
- 5 Place the entire Power Distribution Unit into the pedestal opening as follows:
 - a There is one main key hole in the center, which is used to properly center and secure the unit in place.
 - b There are also five lock screws on the outer edges of the Power Distribution Unit that must be properly secured to the pedestal.
- 6 Attach the fan blower (located behind pedestal) to the Power Distribution Unit.
- 7 Connect the power cable to the external, individual shelf cables.
 - a For outside power, connect the **battery (BAT)** power to feeds 0 – 3.
 - b For outside power, connect the **battery return (BRTN)** power to feeds 0 – 3.
 - c Attach the **logic return (LRTN)** power to the LRTN unit.
- 8 Attach the frame ground wire to the pedestal.
- 9 Insert the XSM slot into the Power Distribution Unit.
- 10 Tighten the two outer screws (located on the XSM slot) to lock in place.
- 11 Re-attach the XSM ribbon connector.

End of Procedure

PDU connections

A readily accessible disconnect device for input power is required.

CAUTION

DC power for the NT4N49 must be provided with circuit protection of 30 amps for each feed (-BAT 0, -BAT 1, -BAT 2, and -BAT 3).

Circuit breakers must be located next to each other and labeled to show that both must be shut off to remove all power to the system.

Figure 28
PDU circuit protection with standard 2 feed wiring

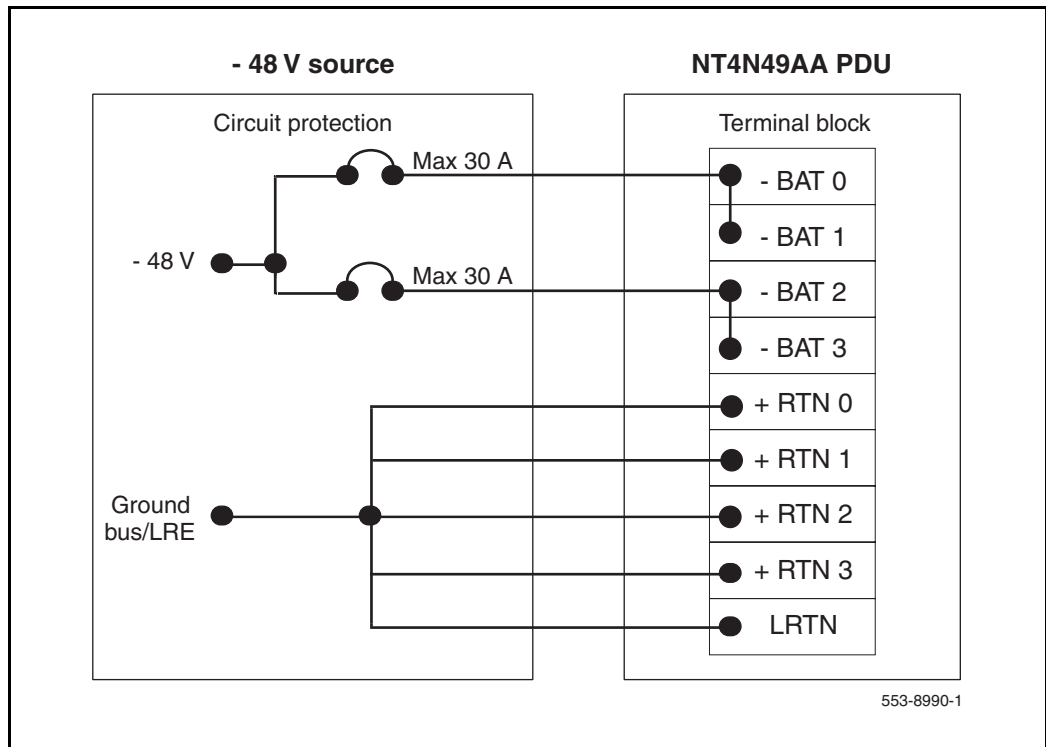
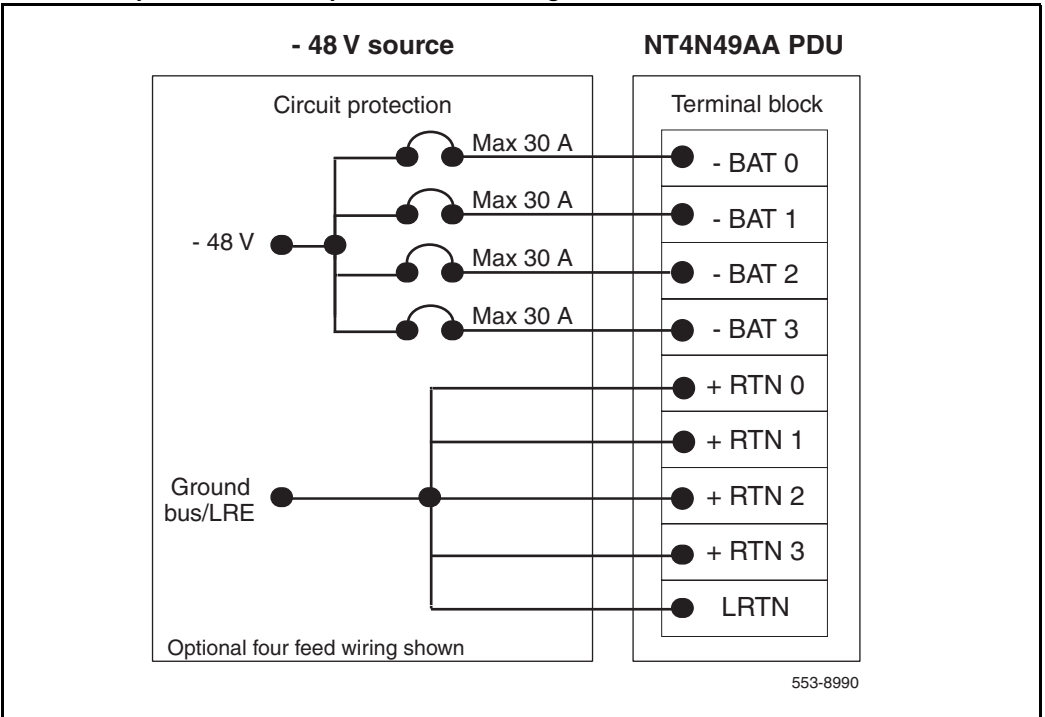

Figure 29
PDU circuit protection with optional 4 feed wiring



A maximum loop drop of two volts is allowed between the pedestal, or junction box, and the external power equipment. See Table 25 for allowable wire sizes. See *Meridian 1 power engineering* (553-3001-152) for detailed information on calculating wire size.

Table 25
Wire gauge requirements for 30-amp feeds

Length	#8 AWG	#6 AWG	Single #4 AWG	Double #4 AWG
0–3 m (10 ft)	Yes	Yes	Yes	Yes
3–6 m (20 ft)	Yes	Yes	Yes	Yes
6–9 m (30 ft)	Yes	Yes	Yes	Yes
9–12 m (40 ft)	Yes	Yes	Yes	Yes
12–15 m (50 ft)	Yes	Yes	Yes	Yes
15–18 m (60 ft)	No	Yes	Yes	Yes
18–21 m (70 ft)	No	Yes	Yes	Yes
21–24 m (80 ft)	No	Yes	Yes	Yes
24–27 m (90 ft)	No	No	Yes	Yes
27–30 m (100 ft)	No	No	Yes	Yes
30–60 m (200 ft)	No	No	No	Yes
over 60 m (200 ft)	No	No	No	No

Note 1: Two 30-amp feeds are typically adequate for a column with four modules (five wires total—two 30-amp feed pairs plus logic return).

Note 2: If dual conduit is used, the wires must be run in battery/battery return pairs, with one pair in one conduit and the other two pairs, plus logic return, in the other conduit.

Legend: Yes= Wire size is adequate for the distance.
No= Wire size has too high a voltage drop and is inadequate for the distance.

The following equipment is located in the rear of each pedestal (see Figure 32 on page 115) in Meridian 1 columns:

- The PDU distributes power to the entire column.
- The field wiring terminal provides the connection point for wiring brought into the pedestal.
- A circuit breaker is provided for each module in the column and for the blower unit
- All column circuit breakers trip if a column thermal overload is detected or a DC-power low-voltage condition is sensed.
- The system monitor checks the column temperature, cooling system status, system voltage status, controls alarms, and line transfer states accordingly.

Figure 30
DC power equipment in the rear of the pedestal—NT4N49 DC PDU

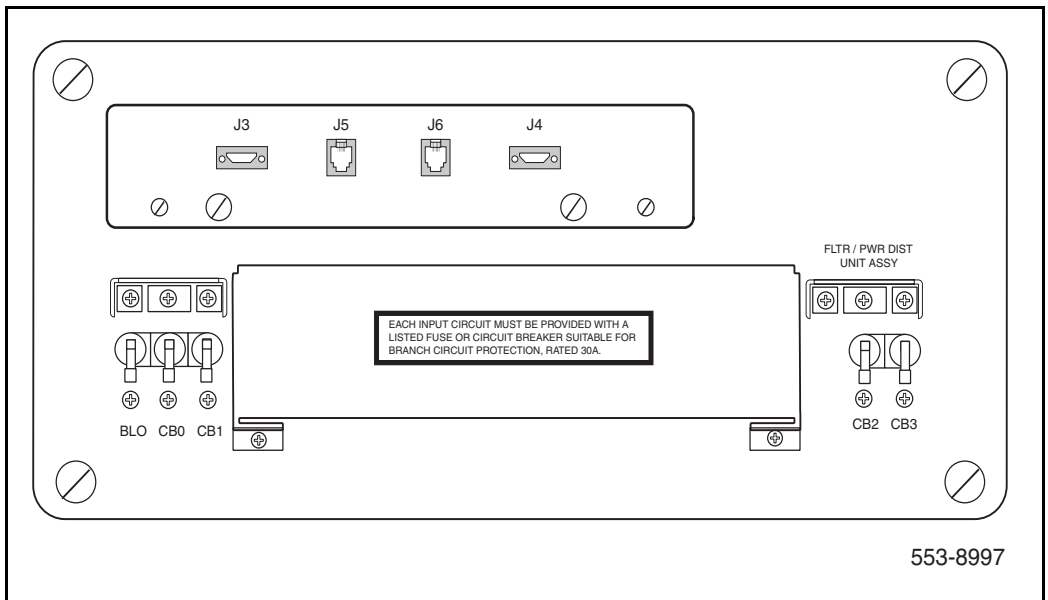

With the NT4N49 DC PDU, the safety ground/protective earth wires and all wiring to the terminal block in the PDU must be neatly routed within the cable-tie saddles and under the cable restraint bar at the base of the pedestal (see Figure 32). This ensures that there is room to install the PDU cover, safety cover, and rear grill.

Conduit is not required with the NT4N49 DC PDU. However, conduit can be used if local codes or individual installations require it. Conduit can be routed down through the column from overhead racks or up through the floor. Conduit clamps and the hardware to fasten the conduit are provided in the pedestal.

Figure 31
Cable routing in the rear of the pedestal—NT4N49 DC PDU
with standard 2 feed wiring

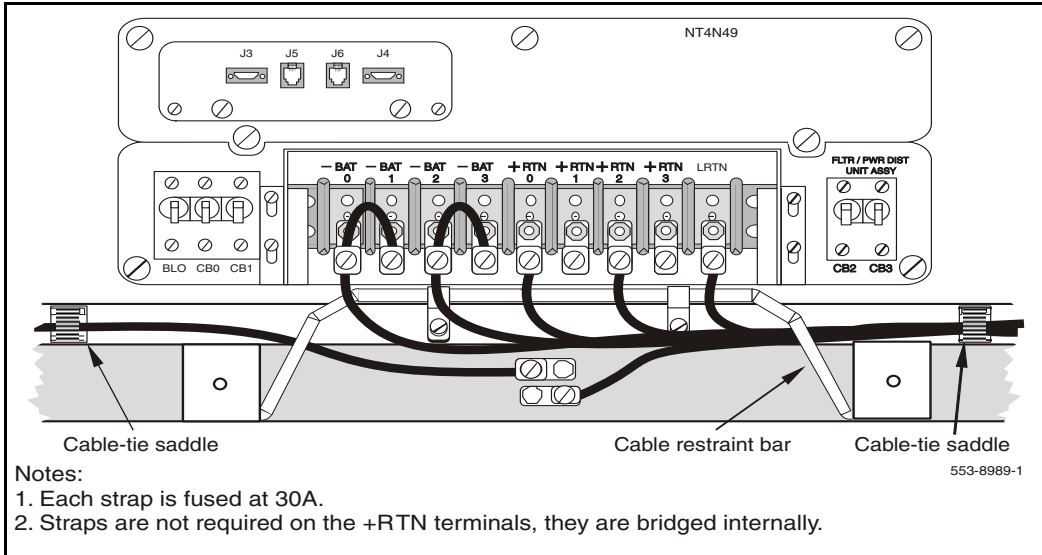
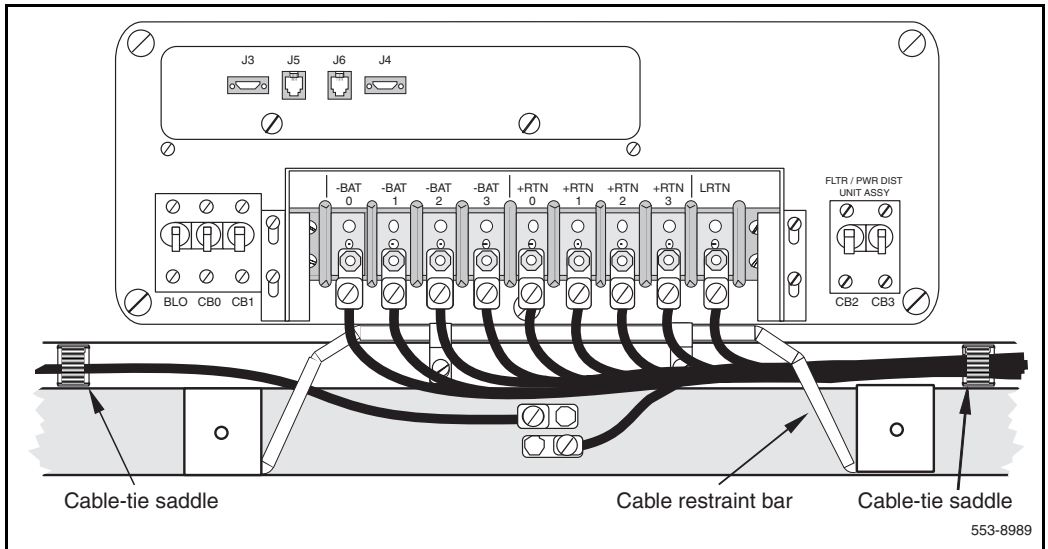

Figure 32
Cable routing in the rear of the pedestal—NT4N49 DC PDU
with optional 4 feed wiring



Power connection from power plant to NT4N49 DC PDU

Note 1: On columns which have only two modules, run five wires to facilitate future expansion to a four module column.

Note 2: If only two modules are used in the column, set the CB2 and CB3 circuit breakers to off.

- 1 Ensure that power to the power plant is removed from the service panel.
- 2 Remove the air intake grill from the rear of the column pedestal being wired:
- 3 Remove the two screws securing the air intake grill to the pedestal.
- 4 Use a screwdriver to remove the PDU safety cover.
- 5 Route the wires between the power plant and the pedestal of the column being wired.

- 6 If a junction box is used continue with procedure step 8, if not, go to procedure step 10.
- 7 If a junction box is used, insert the conduit from the junction box into each of the conduit access holes in the pedestal.
- 8 Route the wires within the cable-tie saddles and under the cable restraint bar at the base of the pedestal.
- 9 Connect the wires to the matching connections on the terminal block on the junction box:
 - a Connect the red wires to BAT 0, BAT 1, BAT 2, and BAT 3.
 - b Connect the black wires to BRTN 0, BRTN 1, BRTN 2, and BRTN 3.
 - c Connect the orange or white wire to LRTN.
- 10 If no junction box is used, route two red wires between the power plant and the pedestal of the column being wired.
- 11 Route two black wires between the power plant and the pedestal of the column being wired.
- 12 Route one (orange or white) wire for the logic return ground (LRTN) between the power plant and the pedestal of the column being wired.
- 13 Route the wires within the cable-tie saddles and under the cable restraint bar at the base of the pedestal.
- 14 Connect wires to the PDU as follows:
 - a Connect a red wire to -BAT 0 for Module 0 and -BAT 1 for Module 1, and another red wire to -BAT 2 for Module 2 and -BAT 3 for Module 3 on the connection block.
 - b Connect a black wire to +BRTN 0 for Module 0 and +BRTN 1 for Module 1, and another black wire to +BRTN 2 for Module 2 and +BRTN 3 for Module 3 on the connection block.
 - c Connect the (orange or white) wire to the LRTN terminal on the connection block.
- 15 Connect wires to the power plant as follows:

- a** Connect the red wires to the first available circuit breakers in the main control/distribution panel. See Figure 33 on page 118 for PDU to MFA150 connections and Figure 34 on page 119 for PDU to System 600/48 connections. Each new column connects the next available circuit breakers.

Note: If only two modules are used in the column, ensure that the CB2 and CB3 circuit breakers are set to OFF.

- b** Connect the black wires to the ground bus/LRE.
 - c** Connect the orange or white wire to ground bus/LRE.
- 16** Replace the metal safety cover over the terminal block on the PDU.
- a** Lower the front panel over the mounting screws on the PDU.
 - b** Tighten the screws holding the cover.
- 17** Replace the power plant cover.
- 18** Replace the junction box cover.

————— *End of Procedure* —————

Figure 33
PDU to MFA150 connections

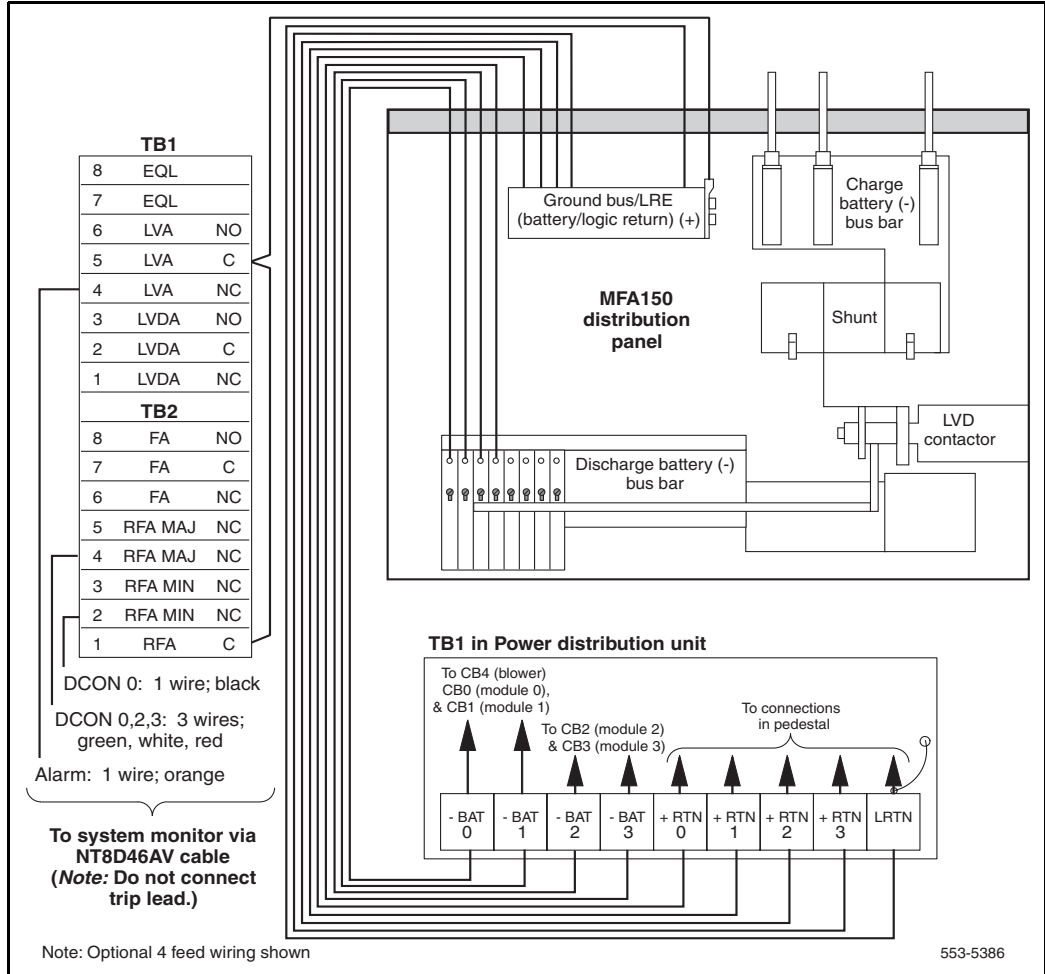
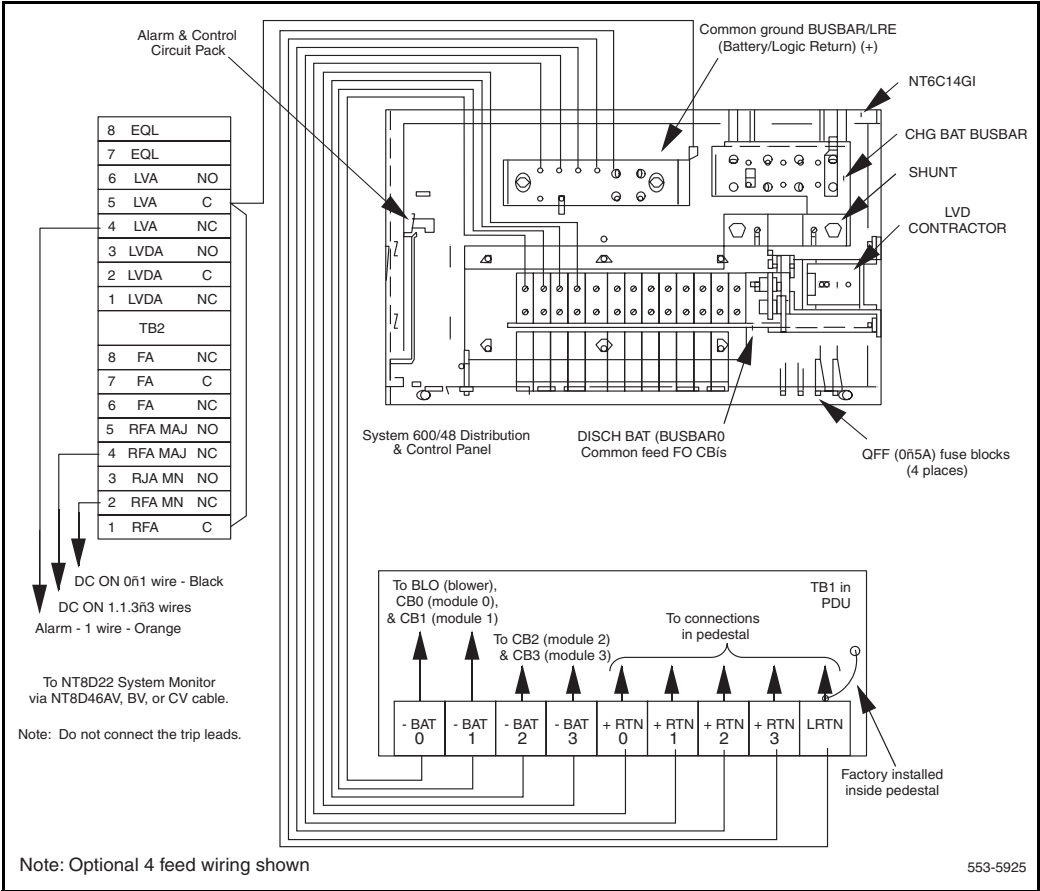

Figure 34
PDU to System 600/48 Power Plant connections



Connecting Meridian Power DC to the NT4N49 DC PDU

To connect the external power system to the pedestal, use the following procedure for each column (this procedure gives the connections for a four-module column).

Note: All wiring to the PDU must be routed within the cable-tie saddles and under the cable restraint bar at the base of the pedestal.

Procedure 3

Connect Meridian Power DC to the NT4N49 DC PDU

- 1 Open the front door of the 8B/2R or 8B/4R master power cabinet.
 - 2 If a junction box is used, insert the conduit from the junction box into each of the conduit access holes in the pedestal.
 - 3 Connect the wires from the junction box to the matching connections on the terminal block on the PDU:
 - a Connect the red wires BAT 0 through BAT 3.
 - b Connect the black wires BRTN 0 through BRTN 3.
 - c Connect the remaining LRTN wire (orange or white wire).
- Note:** If a junction box is used, the connections described in Steps 2 through 5 apply to the junction box rather than the pedestal.
- 4 Connect the red BAT (–48V) wires as follows:
 - a At the 8B/2R or 8B/4R master power cabinet, connect wires to the first terminals on the –ve distribution rail (see Figure 35).
 - b At the PDU, connect the wires to the terminal block. Connect a red wire to -BAT 0 for Module 0 and -BAT 1 for Module 1, and another red wire to -BAT 2 for Module 2 and -BAT 3 for Module 3 on the connection block.
 - 5 Connect the black BRTN (+48V) wires as follows:
 - a At the 8B/2R or 8B/4R master power cabinet, connect wires to the +ve bus.
 - b At the PDU, connect the wires to the terminal block. Connect a black wire to +BRTN 0 for Module 0 and +BRTN 1 for Module 1, and another black wire to +BRTN 2 for Module 2 and +BRTN 3 for Module 3 on the connection block.

- 6 Connect an orange #8 AWG (10 sq mm) LRTN wire from the logic return equalizer (LRE) in the rear of the master power cabinet to LRTN on terminal block TB1 in the pedestal (see Figure 35 on page 122).
- 7 Reinstall the metal safety cover over the terminal block as follows:
 - a Lower the front panel over the mounting screws on the PDU.
 - b Tighten the screws holding the cover.
- 8 Close the covers on the 8B/2R or 8B/4R master power cabinet.

————— *End of Procedure* —————

System Monitor connections

When connecting to an 8B/2R or 8B/4R Master Power Cabinet, one NT8D46AT cable is required to extend the alarm terminal to the Master System Monitor in the pedestal. See Figure 33.

The orange colored wire on NT8D46AT marked “ALARM” extends from any of three alarm terminals on the top of the power cabinet to connector marked J4 in the system monitor. The remaining “Trip” and “DC ON” wires on the NT8D46AT cable are not used and should be snipped before installing the cable.

Figure 35
UEM to 8B/4R Master Power Cabinet 2R or
8B/4R Master Power cabinet connections

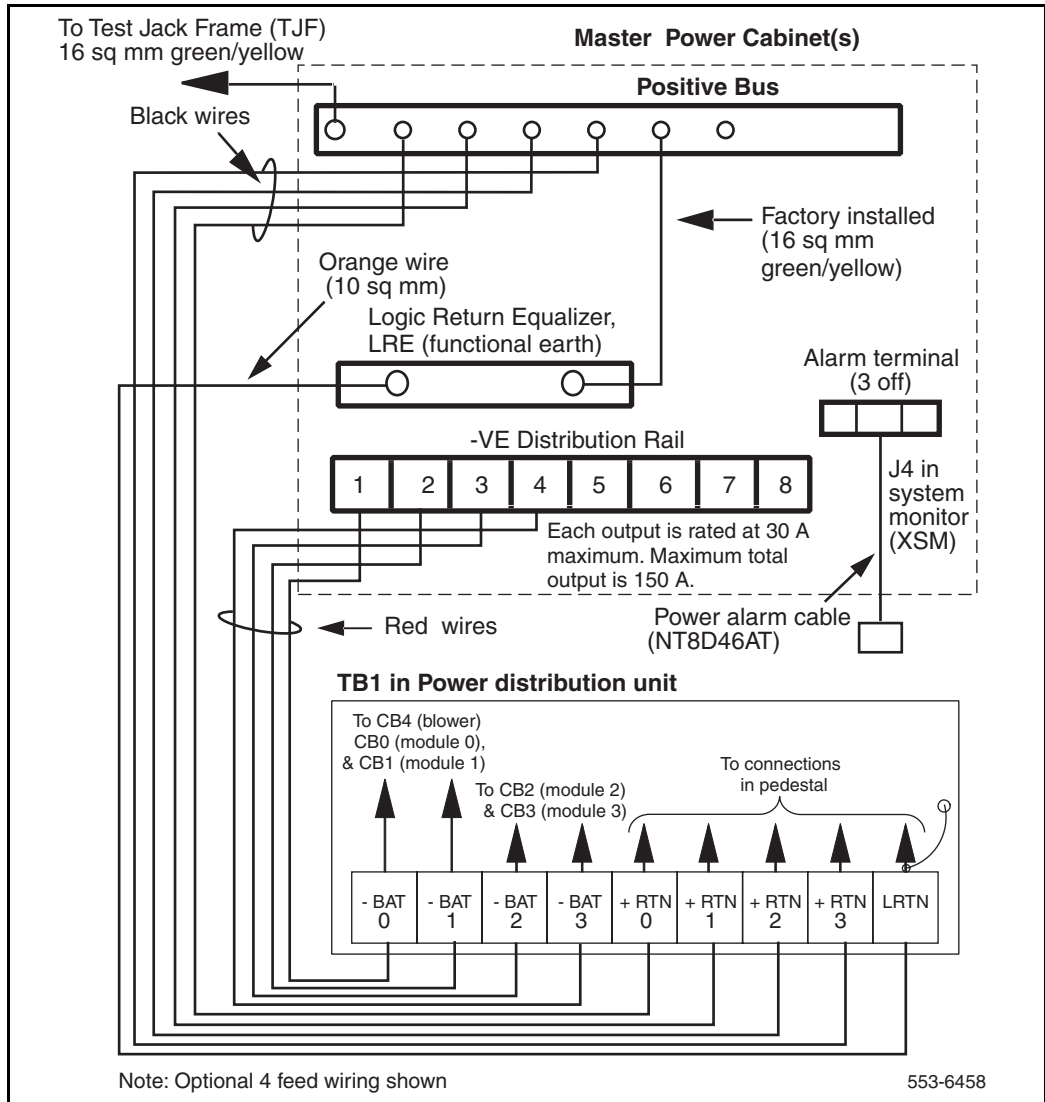

DC Power Distribution Unit Replacement

Contents

The following are topics in this section:

[Introduction](#) 123
[Replacement preparation procedures](#) 123

Introduction

This chapter explains how to replace an NT4N50 with an NT4N49 in DC-powered systems.

Note 1: The NT4N49 replaces the NT4N50. However, both PDUs can be used in a system.

Note 2: Conduit is not required with the NT4N49, but can be used.

Note 3: This procedure is similar to replacing the NT7D10 with the NT4N49AA, except that the user must also access the blower and remove the L-bracket. The L-bracket can be discarded.

Replacement preparation procedures

Before you begin this procedure:

- Additional wire may be required (see Step 2 below)..

WARNING

Module covers are *not* hinged; do not let go of the cover. Lift the cover away from the module and set it out of your work area.

Procedure 4
Prepare for replacement

- 1 Disconnect DC power at the source (not at the PDU).

CAUTION

Before performing these procedures, disconnect the power at the source; simply turning off the circuit breakers does not shut off power to the system monitor. Verify the power is disconnected by using a volt meter. Test all -BAT and +RTN terminals.

- 2 Remove the grill on the rear of the pedestal.
- 3 Check the length of existing wire to the PDU. Due to the location of the field wiring terminal block on the NT4N49, 6 to 9 inches additional length is required to reach its terminals than is required to reach those on the PDU being replaced.

Note 1: The existing service loop, where wire enters the pedestal, may not have enough excess length, or enough slack wire may exist in the conduit path from the power plant to allow pulling a sufficient amount through to the pedestal. Figure 38 on page 129 shows the location on the NT4N49 to which wiring must extend. If existing wiring does not reach, replace the entire wire run from the power plant. Do *not* splice short pieces of wire onto the end of existing wiring.

Note 2: If a QCAD321 or an NT6D53 junction box is installed on the power feed to the console, the wiring from the power plant can be altered as follows:

- If five #4 AWG wires connect the power plant to the junction box (two BAT, two BRTN, and one LRTN), then the junction box must be removed and the wire from the power plant to the pedestal must be replaced. Do *not* splice short pieces of wire onto the end of existing wiring.
- If nine #4 AWG wires connect the power plant to the junction box (four BAT, four BRTN, and one LRTN), then the junction box can be used. However, the #10 AWG wires from the junction box to the pedestal may have to be replaced to provide sufficient length. Do *not* splice short pieces of wire onto the end of existing wiring.

- 4 Set all five circuit breakers on the PDU to OFF (down). Figure 36 shows the NT4N50 in the rear of the pedestal.

Figure 36
NT4N50 DC PDU

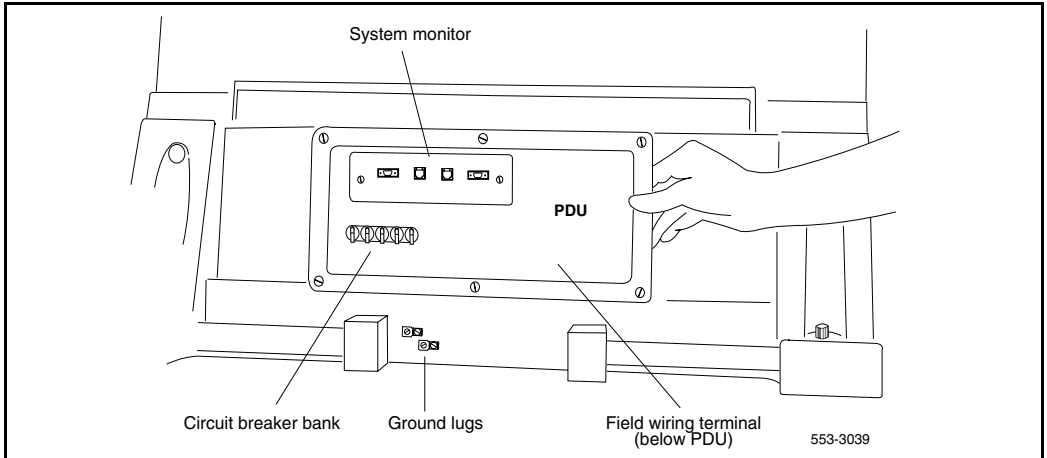

- 5 Remove the blower unit in the front of the pedestal as follows:
 - a Remove the grill on the front of the pedestal.
 - b Set the toggle switch on the front of the blower unit to OFF (left).
 - c Turn the screws on the front of the unit counterclockwise and pull the unit out several inches so the connector on the rear disengages.
 - d Remove the blower unit completely from the pedestal.

WARNING

The unit is heavy and the blades on the blower can rotate up to two minutes after the power is turned off.

- 6 Unscrew the two screws which secure the PDU to the dividing plate which is located behind the back of the blower. The two screws can be discarded since they are not longer needed.
- 7 Disconnect cables to the module above the pedestal (Module 0) as follows:

- a Remove the rear cover on the module.
- b Remove the I/O safety panel over the backplane in the module.
- c Disconnect the system monitor ribbon cable from the PDU and from the module and set it aside for re-connection with the replacement NT4N49.
- d Disconnect the large orange power connector (J1) from the PDU.

Note: To disconnect the power plug, you must press a latch trip on the front and rear of the plug. You may need to use a screwdriver blade against the latch trip on the front of the plug.

- 8 Tag and disconnect cables to the NT8D22 System Monitor card. Loosen the two screws on the card faceplate and remove it.

Note: In some cases, two screws must be removed with a L-bracket from the front once the blower has been removed. These can be found close to the plug used to connect the blower. Discard these screws and the L-bracket.

- 9 Remove the five screws that position the PDU being replaced. Carefully pull the unit straight out and set it on the floor next to the pedestal (see Figure 37).

CAUTION

The PDU cannot be completely removed from the pedestal until wires to the field wiring terminal block are disconnected. Label wires carefully. Improper wiring can cause system damage.

Figure 37
Cabling between the PDU and the field wiring terminal blocks

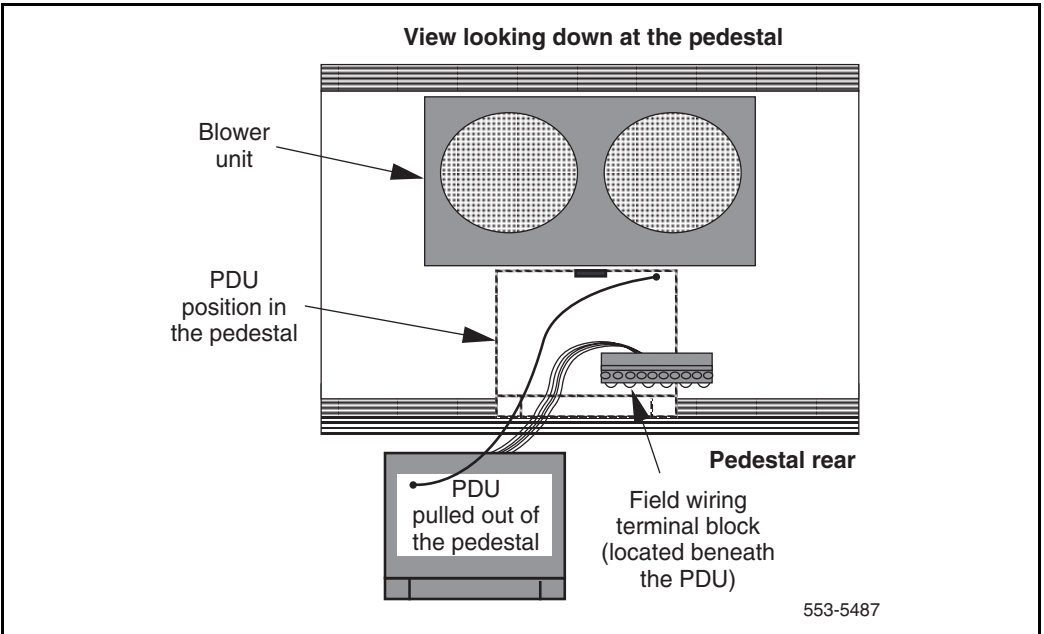

- 10 Tag and then disconnect all wiring to the field wiring terminal block.
- 11 Locate the frame ground wire from the field wiring terminal block to the frame ground bolt inside the pedestal. Disconnect this wire at the ground bolt.
- 12 Remove the field wiring terminal block on the NT7D10 PDU as follows:
 - a Remove the cover over the terminal block.

WARNING

You should support the PDU as far into the pedestal as you can without letting it drop to the bottom of the pedestal, but watch your hands! It becomes more difficult to support the PDU the further into the pedestal it is inserted. The PDU is held in its proper position only when the mounting screws on its faceplate are tightened.

- b** Remove the four screws that secure the terminal block and lift it out of the pedestal
- 13** Move the NT4N50 out of the work area.
- 14** Remove the (green) ground wire from the back of the pedestal.
- 15** Remove the XSM unit from the XSM slot.
- 16** Remove the monitoring cables from the XSM ribbon connector.
- 17** Remove the entire Power Distribution Unit into the pedestal opening by:
 - a** Unscrewing the main key hole in the center.
 - b** Unscrewing the five lock screws on the outer edges. NT4N49 DC PDU.
- 18** Replace the existing PDU with the NT4N49 as follows:
 - a** Connect the green frame ground wire from the PDU to the frame ground bolt inside the pedestal.
 - b** Guide the power cable connector through the hole in the top of the pedestal. Set the PDU in the pedestal and tighten the three screws that secure it to the pedestal.
- 19** Install the NT8D22 system monitor assembly as follows:
 - a** Connect the XSM ribbon cable (set aside when the NT4N50 was removed) to the system monitor (XSM slot – J2).
 - b** Gently push the XSM cable into the pedestal. Guide the connector on the other end of the cable through the hole in the top of the pedestal and connect it to Module 0.
- 20** Tighten the screws (one main key hole and five lock screws) that secure the system monitor assembly.
- 21** Reconnect the cables from Module 0 as follows:
 - a** Reconnect the large orange power connector (J1).
 - b** Replace the I/O safety panel.
 - c** Replace the rear cover on the module.
- 22** Reconnect all external wiring to the terminal block on the PDU as follows (see Figure 38):
 - a** Remove the plastic safety cover over the terminal block.

- b Connect the red BAT (–48 V) wires as follows:
 - for Module 0, connect to the BAT 0 terminal
 - for Module 1, connect to the BAT 1 terminal
 - for Module 2, connect to the BAT 2 terminal
 - for Module 3, connect to the BAT 3 terminal
- c Connect the black BRTN (48 V return) wires as follows:
 - for Module 0, connect to the BRTN 0 terminal
 - for Module 1, connect to the BRTN 1 terminal
 - for Module 2, connect to the BRTN 2 terminal
 - for Module 3, connect to the BRTN 3 terminal
- d Connect the orange (or white) wire from the ground bus/LRE in the power plant to the LRTN terminal.

Figure 38
NT4N49 field wiring terminals

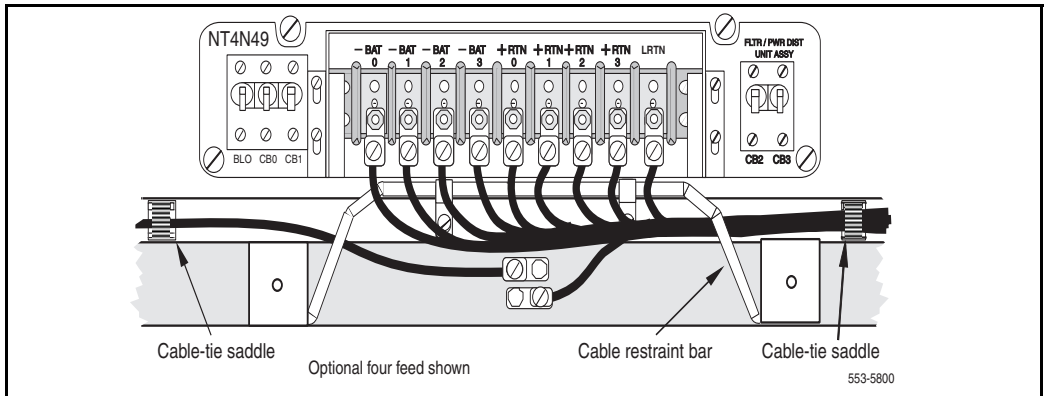

- 23 Position the conduit attachment plate on the rear of the pedestal and secure it with two screws, nuts, and washers.
- 24 Reinstall the plastic safety cover over the terminal block.
- 25 Reseat the blower unit as follows:
 - a Lift the unit slightly and slide it into the pedestal glides. Set the toggle switch to ON (right).
 - b Tighten the screws on the front of the unit.

- c Replace the front pedestal grill.
- 26 Insert the system monitor card.
- 27 Tighten the screws on the card faceplate.
- 28 Reconnect cables to the system monitor.
- 29 Set all five circuit breakers on the PDU to OFF (down).
- 30 Reconnect the DC power source.
- 31 One at a time, starting with the breaker for the blower unit, set the circuit breakers on the PDU to ON (up). Make sure the green LED lights on the power supply unit(s) in each module.
Note: On initial power up, the blower may rotate slower than expected. As the sensor detects heat, the blower rotates more rapidly.
- 32 Replace the rear pedestal grill.
- 33 Tag defective equipment with a description of the problem and package it for return to a repair center.

————— *End of Procedure* —————

Index

Symbols

“delta” service wiring method, 10

“wye” service wiring method, 10

Numerics

21 through 61 system options

 21A with AC power only, 52

600/48, 60

71/81 system options

 DC systems for, 52

A

absolyte batteries, 48

AC Equipment Ground (ACEG), 23

AC power systems

 described, 12, 13

 input specifications, 26

 internal power distribution, 27

 reserve power for, 42

AC service panel, 23

AC/DC converters, 32, 42

ACEG (AC equipment ground), 20, 22, 23

ACEQ (AC equipment ground), 21

alarm and monitoring features

 for power units, 53, 57, 61, 73

 for UPS units, 46

Alpha Technologies (UPS vendor), 47

amperes

 and wire characteristics, 98

 outputs for AC, 31

 outputs for DC, 37

B

batteries

- for reserve power, 42, 48
- input specifications, 32
- lead-calcium/absolyte, 48
- maximum allowable voltage drops, 98
- with DC-powered systems, 14, 32

battery return (BR), 17

Best Power Technology (UPS vendor), 47

Blower Units

- in PDU replacement, 129

brownouts, 13

building principal ground (BPG), 16

building steel as ground, 23

C

cables

- in PDU replacement, 125, 128

cabling requirements

- caution when connecting to UPS unit, 44
- for UPS-to-system alarm monitors, 47
- selecting wire sizes, 33, 97

CEC (Canadian Electrical Code), 10

chargers, 32

chassis ground, 20

circuit breakers, 35

- DC power, 110

circuit card power consumption, 85

circuit protection, 25

commercial power sources, 13

conversion

- metric, 100
- metric wire, 100

converters

- AC/DC, 32, 42
- DC/AC, 42

D

daisy-chaining, 20, 21, 22

DC (direct current) power systems

- PDU connections, 108

DC power systems
described, 12, 13, 14, 32
external power distribution, 38
input specifications, 32
internal power distribution, 33
multiple-column distribution, 76, 78
reserve power for, 47

DC/AC converters, 42

documentation, 9

E

electromagnetic compatibility (EMC)
Single Point Grounding (SPG), 18

EMI (electromagnetic interference) filter, 29

Enhanced Existing Peripheral Equipment (EEPE), 36

environmental considerations
for NT5C03 rectifier (with J2412 power plant), 70
for NT6D82 Power System, 76

European Industry standard metric measurements, 100

Exide Electronics (UPS vendor), 47

external power distribution for DC power systems, 38

external versus internal power components, 12, 13

F

floor ground bar (FGB), 16

floor loadings
for MFA150 Modular Front Access Power System, 56
for MPP600 Modular Power Plant, 59, 64
for QCA13 cabinet (for J2412 DC power plant), 67

frame ground, 20

frequencies
for MFA150 Modular Front Access Power System, 55
for MPP600 Modular Power Plant, 58, 63
outputs for AC, 31
outputs for DC, 37

G

GFCI (ground fault circuit interrupt) devices, 26

global PDU, 105

grounding
LRE (logic return equalizer), 21, 22, 23
NT6D82 Power System, 77
safety ground, 19

grounds

identifying good grounds, 24

H

heat dissipation

for MFA150 Modular Front Access Power System, 56

for MPP600 Modular Power Plant, 59, 64

for NT6D82 Power System, 76

humidity considerations

for NT5C03 rectifier (with J2412 power plant), 70

for NT6D82 Power System, 76

I

IBN (Isolated Bonding Network), 16

identifying good grounds, 24

IG (isolated ground), 20

internal versus external power components, 12, 13

inverters (DC/AC converters), 42

Isolated Bonding Network (IBN), 16

J

J2412 DC power plant

cabinet, 67

rectifiers and distribution box, 69

junction box in PDU replacement, 124

junction boxes

related documentation, 33

L

lead-calcium/absolyte batteries, 48

LRE (logic return equalizer), 21, 22, 23

M

Meridian 1 power systems

overview, 11

upgrades, 92

wire size selection, 97

metric conversion, 100

metric wire conversion, 100

MFA150 Modular Front Access Power System

as upgrade, 92

described, 52

specifications, 55

MFA150 Modular Power Systems, 105
modular power systems, 105
 PDU connections, 119
MPDU (module power distribution unit), 27, 30
MPP600 Modular Power Plant
 as upgrade, 92
 described, 57
 specifications, 58, 63
MPP600 Modular Power Systems, 105
 PDU connections, 119
multiple-column distribution, 78

N

NEC (National Electric Code), 23, 47
NEC (National Electrical Code), 10
noise specifications
 for MFA150 Modular Front Access Power System, 55
 for MPP600 Modular Power Plant, 58
 for NT5C03 rectifier (with J2412 power plant), 70
NT0R72 Switched Mode Rectifier, 38
NT5C03/07 rectifiers (with J2412 power plant), 69, 70
NT5C90EF and EG power systems, 52
NT5K12 EPE Power Supply (International), 37
NT5K12AA Power Supply (EPEPS)
 international, 36
NT6D39DC CPU/Network module
 power consumption, 88
NT6D40 PE Power Supply
 compatibility considerations, 36
 described, 36
 output voltages and currents, 37
NT6D41 CE Power Supply
 compatibility considerations, 36
 described, 36
 output voltages and currents, 37
NT6D42 ring generator
 compatibility considerations, 36
 output voltages and currents, 37
NT6D43 CE/PE Power Supply
 compatibility considerations, 36
 output voltages and currents, 37
NT6D44 Meridian Mail Module
 power consumption, 88

- NT6D60BA Core module
 - compatibility considerations, 36
 - power consumption, 88
- NT6D82 Power System
 - as upgrade, 92
 - described, 73
 - external DC power configurations, 76
 - grounding, 77
 - specifications, 75
 - upgraded distribution example, 79
- NT7D10AA PDU
 - for power delivery from distances, 33
 - global replacement for, 35
- NT7D10CA System Monitor/Power Supply Assembly, 35
- NT7D10DA PDU
 - for power delivery from distances, 33
 - global replacement for, 35
- NT7D12 Rectifier Rack Assembly, 38, 40
- NT7D67CB PDU, 33
 - power to, 115
 - safety ground, 114
- NT8D06 PE power supply
 - compatibility considerations, 30
 - output voltages and currents, 31
- NT8D11AC CE/PE module
 - power consumption, 88
- NT8D11DC CE/PE module
 - compatibility considerations, 36
- NT8D13 PE module
 - DC option compatibility considerations, 36
 - power consumption, 88
- NT8D13AA PE module
 - AA option compatibility considerations, 30
- NT8D21 ring generator
 - compatibility considerations, 30
 - output voltages and currents, 31
- NT8D29CE power supply
 - compatibility considerations, 30
 - output voltages and currents, 31
- NT8D34 CPU module
 - power consumption, 88
- NT8D34AA CPU module
 - AA option compatibility considerations, 30

- NT8D35 Network module
 - DC option compatibility considerations, 36
 - power consumption, 88
- NT8D35AA Network module
 - AA option compatibility considerations, 30
- NT8D36 InterGroup module
 - power consumption, 88
- NT8D37 IPE module
 - DC option compatibility considerations, 36
 - power consumption, 88
- NT8D37AA IPE module
 - AA option compatibility considerations, 30
- NT8D46AJ/AQ/AU UPS-to-system monitor alarm cables, 47
- NT8D47 RPE module
 - DC option compatibility considerations, 36
 - power consumption, 88
- NT8D56AA/AC MPDU
 - compatibility considerations, 30
- NT8D57AA MPDU
 - compatibility considerations, 30
- NT9D11 Core/Network module
 - power consumption, 88

O

- off-premise line protection, 25
- OSHA requirements for battery handling, 47

P

- PDU (power distribution unit), 105
 - connections, 108
 - described, 12, 13
 - for AC distribution, 27
 - for AC-powered systems, 29
 - for DC distribution, 33
 - power to, 115
 - safety ground, 114
- pedestals
 - AC and DC delivered to, 13, 52
 - maximum allowable voltage drops, 98, 102
 - PDU's in, 12
 - power consumption, 88
 - wire gauge requirements, 103

- power components
 - internal versus external, 12, 13
- power conditioning, 45, 53
- power consumption
 - calculation guidelines, 89
 - of IPE cards, 85
 - of Meridian 1 modules, 88
 - of PE cards, 86
 - worksheet, 91
- power engineering
 - related documentation, 9
- power service panels, 25
- power systems, 105
- power wiring harnesses
 - described, 12, 33
 - intermodule, 29, 35

Q

- QBL12 distribution box (with J2412 power plant), 69
- QBL15 Power Distribution Box, 39, 41, 92
- QCA13 cabinet
 - for J2412 DC power plant, 67
 - for upgrades, 92
- QPC nnn card power consumption, 86

R

- rectifiers
 - on DC-powered systems, 14, 32, 33, 38
 - powering upgrades from, 92
- references, 9
- reserve power
 - and AC-powered systems, 13, 14, 26, 27, 42
 - and DC-powered systems, 16, 47
- ringing generator, 36
- RL100F50 rectifiers, 73, 74
- RS-232 port protection, 25

S

- sense lead sizes, 100

Single Point Grounding (SPG), 16
 electromagnetic compatibility (EMC), 18
 installation and maintenance, 19
 powering, 19
 protection, 18
 safety, 18
SL-1 system upgrades, 92
SPG (single point ground), 20
steel ground, 23
surge protection, 45, 53
System 600/48 Power Plant, 105
System Monitor
 in PDU replacement, 126, 128
system monitor, 29, 35

T

temperature considerations
 for NT5C03 rectifier (with J2412 power plant), 70
 for NT6D82 Power System, 76
 for wire size calculations, 101

U

UPS (uninterruptible power supply)
 alarm monitoring, 46
 as external component, 13
 described, 42
 how to choose, 42, 43
 installed in series, 27
 installing, 44
 interfacing, 43
 power conditioning, 45
 with AC-powered systems, 13, 26

V

vibration considerations
 for NT5C03 rectifier (with J2412 power plant), 71

voltages

- AC input specifications, 26
- conversion on DC-powered systems, 13, 14, 32
- conversion to DC on AC-powered systems, 13, 26
- DC input specifications, 32
- for MFA150 Modular Front Access Power System, 55
- for MPP600 Modular Power Plant, 58, 63
- for NT5C03 rectifier (with J2412 power plant), 70
- for NT6D82 Power System, 75
- maximum allowable voltage drops, 98, 101, 102
- nominal for Meridian 1 systems documentation, 10
- output for AC power supplies, 31
- regulators, 45
- requirements for reserve batteries, 48
- transient conditions, 13

W

weight

- of MFA150 Modular Front Access Power System, 56
- of MPP600 Modular Power Plant, 59
- of NT5C03 rectifier (with J2412 power plant), 70
- of NT6D82 Power System, 76
- of QBL12 distribution box (with J2412 power plant), 69
- of QCA13 cabinet (for J2412 DC power plant), 67

wire gauge requirements

- DC power, 112

wire sizes

- related documentation, 33
- selecting, 97

wiring methods

- conventions for Meridian 1 systems, 10

Meridian 1
Power engineering

Copyright © 1990–2002 Nortel Networks
All Rights Reserved

Information is subject to change without notice. Nortel Networks reserves the right to make changes in design or components as progress in engineering and manufacturing may warrant. This equipment has been tested and found to comply with the limits for a Class A digital device pursuant to Part 15 of the FCC rules, and the radio interference regulations of Industry Canada. These limits are designed to provide reasonable protection against harmful interference when the equipment is operated in a commercial environment. This equipment generates, uses and can radiate radio frequency energy, and if not installed and used in accordance with the instruction manual, may cause harmful interference to radio communications. Operation of this equipment in a residential area is likely to cause harmful interference in which case the user will be required to correct the interference at their own expense.

SL-1 and Meridian 1 are trademarks of Nortel Networks.

Publication number: 553-3001-152
Document release: Preliminary 11.02
Date: June 2002
Printed in Canada

NORTEL
NETWORKS™

