



**BCM RIs 6.0**

**BCM50 Hardware & Installation**

**Task Based Guide**

**Copyright © 2010 Avaya Inc.  
All Rights Reserved.**

**Notices**

While reasonable efforts have been made to ensure that the information in this document is complete and accurate at the time of printing, Avaya assumes no liability for any errors. Avaya reserves the right to make changes and corrections to the information in this document without the obligation to notify any person or organization of such changes.

**Documentation disclaimer**

Avaya shall not be responsible for any modifications, additions, or deletions to the original published version of this documentation unless such modifications, additions, or deletions were performed by Avaya. End User agree to indemnify and hold harmless Avaya, Avaya's agents, servants and employees against all claims, lawsuits, demands and judgments arising out of, or in connection with, subsequent modifications, additions or deletions to this documentation, to the extent made by End User.

**Link disclaimer**

Avaya is not responsible for the contents or reliability of any linked Web sites referenced within this site or documentation(s) provided by Avaya. Avaya is not responsible for the accuracy of any information, statement or content provided on these sites and does not necessarily endorse the products, services, or information described or offered within them. Avaya does not guarantee that these links will work all the time and has no control over the availability of the linked pages.

**Warranty**

Avaya provides a limited warranty on this product. Refer to your sales agreement to establish the terms of the limited warranty. In addition, Avaya's standard warranty language, as well as information regarding support for this product, while under warranty, is available to Avaya customers and other parties through the Avaya Support Web site: <http://www.avaya.com/support>

Please note that if you acquired the product from an authorized reseller, the warranty is provided to you by said reseller and not by Avaya.

**Licenses**

THE SOFTWARE LICENSE TERMS AVAILABLE ON THE AVAYA WEBSITE, [HTTP://SUPPORT.AVAYA.COM/LICENSEINFO/](http://support.avaya.com/licenseinfo/) ARE APPLICABLE TO ANYONE WHO DOWNLOADS, USES AND/OR INSTALLS AVAYA SOFTWARE, PURCHASED FROM AVAYA INC., ANY AVAYA AFFILIATE, OR AN AUTHORIZED AVAYA RESELLER (AS APPLICABLE) UNDER A COMMERCIAL AGREEMENT WITH AVAYA OR AN AUTHORIZED AVAYA RESELLER. UNLESS OTHERWISE AGREED TO BY AVAYA IN WRITING, AVAYA DOES NOT EXTEND THIS LICENSE IF THE SOFTWARE WAS OBTAINED FROM ANYONE OTHER THAN AVAYA, AN AVAYA AFFILIATE OR AN AVAYA AUTHORIZED RESELLER, AND AVAYA RESERVES THE RIGHT TO TAKE LEGAL ACTION AGAINST YOU AND ANYONE ELSE USING OR SELLING THE SOFTWARE WITHOUT A LICENSE. BY INSTALLING, DOWNLOADING OR USING THE SOFTWARE, OR AUTHORIZING OTHERS TO DO SO, YOU, ON BEHALF OF YOURSELF AND THE ENTITY FOR WHOM YOU ARE INSTALLING, DOWNLOADING OR USING THE SOFTWARE (HEREINAFTER REFERRED TO INTERCHANGEABLY AS "YOU" AND "END USER"), AGREE TO THESE TERMS AND CONDITIONS AND CREATE A BINDING CONTRACT BETWEEN YOU AND AVAYA INC. OR THE APPLICABLE AVAYA AFFILIATE ("AVAYA").

**Copyright**

Except where expressly stated otherwise, no use should be made of the Documentation(s) and Product(s) provided by Avaya. All content in this documentation(s) and the product(s) provided by Avaya including the selection, arrangement and design of the content is owned either by Avaya or its licensors and is protected by copyright and other intellectual property laws including the sui generis rights relating to the protection of databases. You may not modify, copy, reproduce, republish, upload, post, transmit or distribute in any way any content, in whole or in part, including any code and software. Unauthorized reproduction, transmission, dissemination, storage, and or use without the express written consent of Avaya can be a criminal, as well as a civil offense under the applicable law.

**Third Party Components**

Certain software programs or portions thereof included in the Product may contain software distributed under third party agreements ("Third Party Components"), which may contain terms that expand or limit rights to use certain portions of the Product ("Third Party Terms"). Information regarding distributed Linux OS source code (for those Products that have distributed the Linux OS source code), and identifying the copyright holders of the Third Party Components and the Third Party Terms that apply to them is available on the Avaya Support Web site: <http://support.avaya.com/Copyright>.

**Trademarks**

*The trademarks, logos and service marks ("Marks") displayed in this site, the documentation(s) and product(s) provided by Avaya are the registered or unregistered Marks of Avaya, its affiliates, or other third parties. Users are not permitted to use such Marks without prior written consent from Avaya or such third party which may own the Mark. Nothing contained in this site, the documentation(s) and product(s) should be construed as granting, by implication, estoppel, or otherwise, any license or right in and to the Marks without the express written permission of Avaya or the applicable third party. Avaya is a registered trademark of Avaya Inc. All non-Avaya trademarks are the property of their respective owners.*

**Downloading documents**

For the most current versions of documentation, see the Avaya Support. Web site: <http://www.avaya.com/support>

**Contact Avaya Support**

Avaya provides a telephone number for you to use to report problems or to ask questions about your product. The support telephone number is 1-800-242-2121 in the United States. For additional support telephone numbers, see the Avaya Web site: <http://www.avaya.com/support>

Copyright © 2010 ITEL, All Rights Reserved

The copyright in the material belongs to ITEL and no part of the material may be reproduced in any form without the prior written permission of a duly authorised representative of ITEL.

## Table of Contents

<b>BCM50 Hardware &amp; Installation .....</b>	<b>7</b>
Overview .....	7
BCM50 Base Platforms.....	7
BCM50 .....	7
BCM50b .....	8
BCM50e .....	9
BCM50be .....	10
Other Available Features .....	11
BCM50 Platform Field Replaceable Items.....	11
BCM50 Additional Components .....	12
BCM50 Expansion Unit.....	12
Flow Chart .....	13
Wall Mount Bracket.....	14
Rack Mount Shelf .....	15
Desk Mounting the BCM50 .....	15
Wiring Field Card .....	16
Planning the Installation.....	17
Environment Checklist .....	18
Installing the BCM50 Unit in an Equipment Rack .....	19
Installing the BCM50 Wall Mount Bracket.....	20
Installing a BCM50 Expansion Unit.....	23
Supported Media Bay Modules.....	23
Media Bay Module Descriptions .....	24
Media Bay Module Dipswitches .....	29
Installing a Media Bay Module into the Expansion Unit.....	30
Expansion Unit Connections.....	31
Bus Assignment .....	33
Bus Utilisation .....	33
Bus Assignment & Default Line Numbers .....	34
Line Numbering Plan .....	34
Bus Assignment & Default DN Numbers .....	35
Wiring Charts .....	36
Main Unit Amphenol Wiring .....	36
ASM8(+)/GASM/DSM(+) Media Bay Module Amphenol Wiring .....	37
ADID4/8 Media Bay Module Amphenol Wiring .....	38
GATM4/8 Media Bay Module Amphenol Wiring .....	39
G4/8x16 Media Bay Module Amphenol Wiring .....	40
4x16 Media Bay Module Wiring .....	40

BRI Ports.....	41
DTM Ports.....	42
<b>BCM50 Power Supply.....</b>	<b>43</b>
Connecting a Power Supply Using a UPS.....	43
<b>Power Up Procedure.....</b>	<b>44</b>
LED States.....	44
<b>Additional Information.....</b>	<b>46</b>
<b>Replacing Internal Components.....</b>	<b>46</b>
Hard Disk.....	46
Preparing the Multi-Image Hard Drive.....	52
Replacing the Fan.....	56
Replacing the BCM 50(b)e Router Card.....	58
Replacing the Cover of the Main Unit.....	61
<b>Installing the Wiring Field Card (WFC).....</b>	<b>62</b>
Connecting Cables to the Wiring Field Card.....	63
Connecting Cables to the Patch Panel.....	64
<b>Reset Button.....</b>	<b>64</b>
Graceful Reboot.....	64
Immediate Reboot.....	65
<b>BCM Command Line Interface.....</b>	<b>65</b>
Configuration CLI.....	65
Maintenance CLI.....	66
Accessing the Command Line Interface Using PuTTY.....	66
<b>Upgrading to BCM RIs 6.0.....</b>	<b>72</b>
<b>BCM50 Upgrade Flow Charts.....</b>	<b>73</b>
Upgrading from BCM50 RIs 1.0 to RIs. 6.0.....	73
Upgrading from BCM50 RIs 2.0 to RIs. 6.0.....	74
Upgrading from BCM50 RIs 3.0/5.0 to RIs. 6.0.....	75
<b>Pre-Upgrade Activities.....</b>	<b>76</b>
Checking the BCM50 Hardware Version.....	76
Checking the Time Zone is Set Correctly.....	77
Checking the DHCP Server Setting.....	78
Applying the Keycode File.....	79
<b>Performing the Upgrade.....</b>	<b>81</b>
<b>Applying the Factory Image.....</b>	<b>85</b>

Post-Upgrade Activities..... 86

**Avaya Documentation Links ..... 87**

# BCM50 Hardware & Installation

## Overview

BCM50 portfolio includes the following models: the BCM50, BCM50b, BCM50e and BCM50be. This document refers to the hardware components of these units.

## BCM50 Base Platforms

### **BCM50**

The BCM50 Main Unit provides telephony and simple data networking functions. It also provides connections for telephones, lines, and connection to a LAN. Choose the BCM50 if the network already has a router or if you do not require a router.

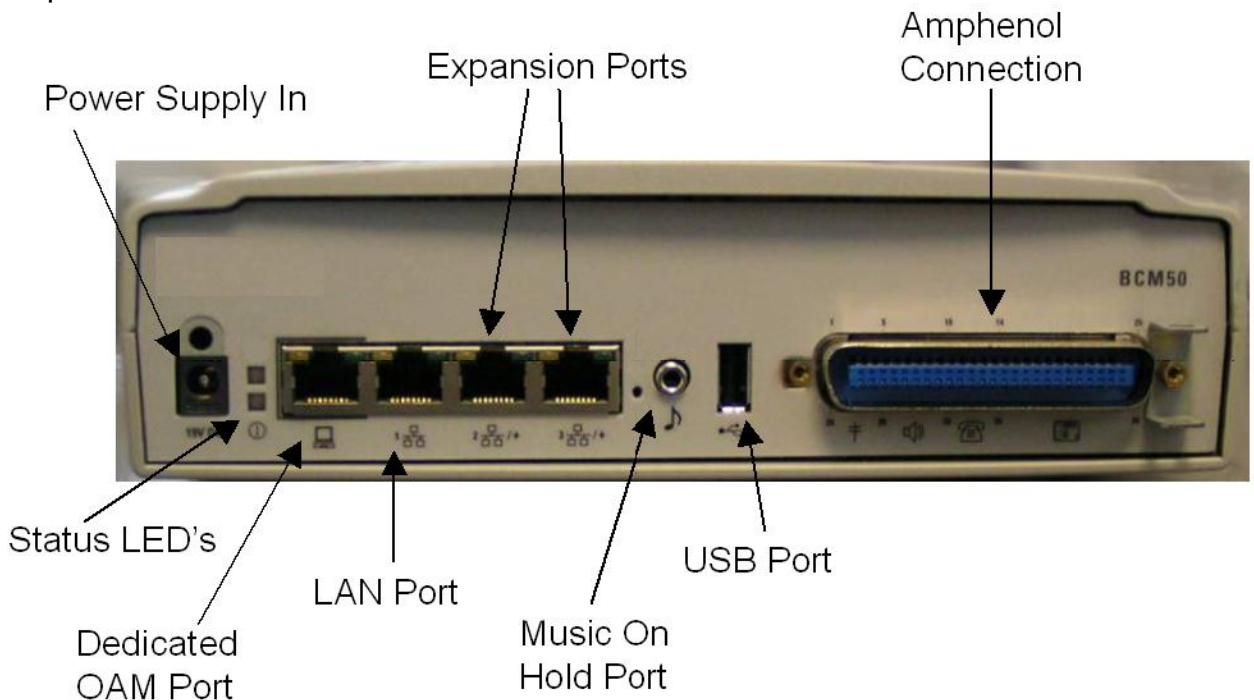

The BCM50 hardware has the following primary components:

- 1 x Dedicated OAM Port for running Element Manager
- 1x RJ45 LAN Port to connect the BCM to the customers LAN
- 2 x Expansion Ports: The expansion ports can provide connections to the internal Ethernet switch within the BCM50 Main Unit. If the BCM50 system does not have BCM50 Expansion Units connected to these ports, you can use them to connect additional devices to the LAN.

- 1 x The Amphenol Connection: used for the connection of Digital Extensions, Analog Trunks (non-b models only), Analog Extensions, Auxiliary Ringer, Page Output, Page Relay, and an alternate Music on Hold device (if MOH device is connected via amphenol, do not use BCM50 faceplate MOH).
- Music source port: A jack used to connect a music source to the BCM50 Main Unit. If you use this port, the music source connections on the amphenol are disabled.
- 1 x USB connection: USB Port is used for the Startup Profile, Loading Keycode files, Backup/Restore, Patch/software Upgrade (check with your Technical Support as to the appropriate method of patch application).
- Status LED's
- Power Connection
- 1 x cooling fan
- CPU: Motorola PowerQUICC II 8270VR Microprocessor
- RAM: 256MB SDRAM
- Hard Disk: 40 GB Maxtor SATA

### **BCM50b**

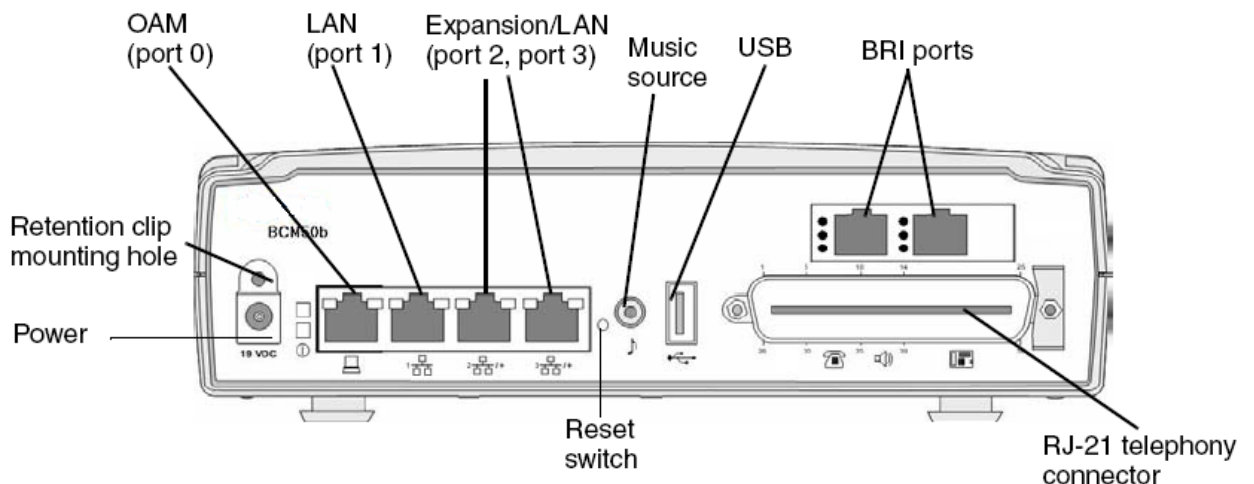

The BCM50b main unit provides similar functionality to the BCM50 main unit.

The difference is that the BCM50b main unit has two integrated BRI ports replacing the four analog trunks on the RJ-21 telephony connector.

- CSC with integrated BRI in place of integrated GATI.
- keycode BRI ports.



## BCM50e

The BCM50e Main Unit provides telephony and data routing features. It also provides connections for telephones, lines, a LAN, and a RJ45 WAN port. The router card of the BCM50e can be connected to a separate Ethernet device such as an ADSL modem or a cable modem to provide Internet access.

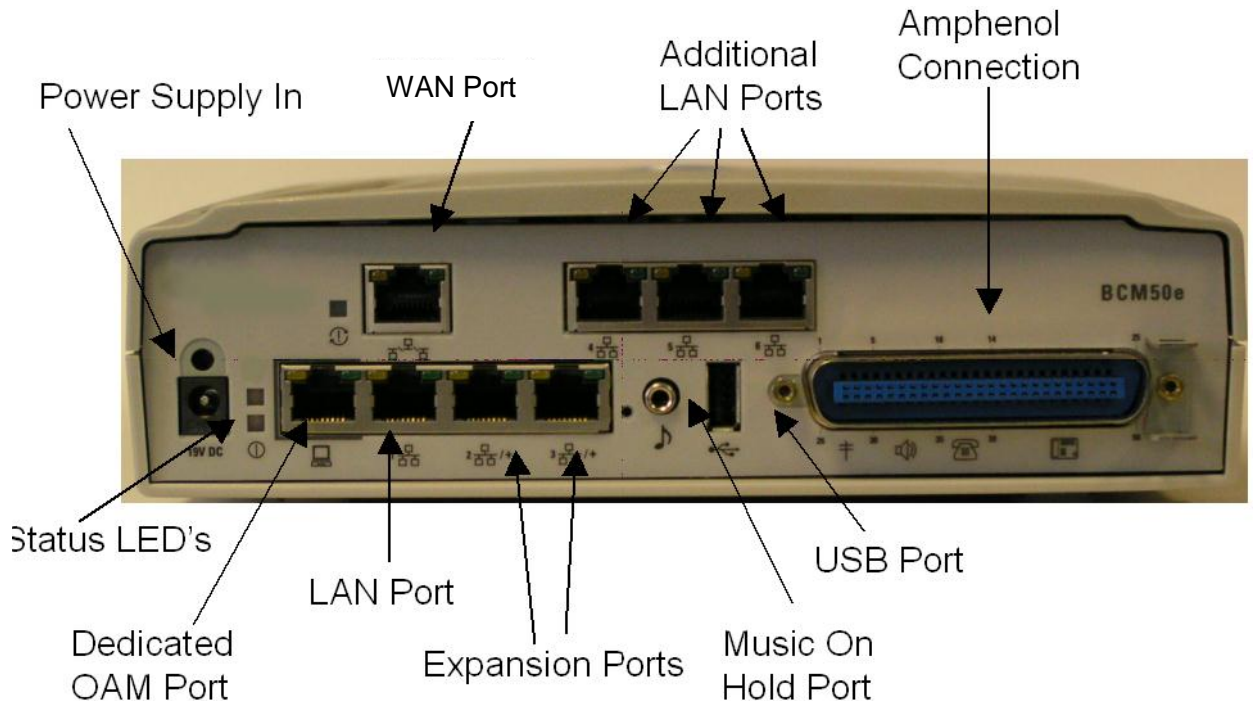

The BCM50e hardware has the following primary components:

- 1 x Dedicated OAM Port for running Element Manager
- 1x RJ45 LAN Port to connect the BCM to the customers LAN
- 2 x Expansion Ports: The expansion ports can provide connections to the internal ethernet switch within the BCM50 Main Unit. If the BCM50 system does not have BCM50 Expansion Units connected to these ports, you can use them to connect additional devices to the LAN.
- 3 x RJ-45 interfaces: that provide connections to the ethernet switch in the BCM50e Main Unit. You can use these ports to connect additional devices to the LAN.
- 1x RJ45 WAN port: that can be utilised to connect to the ethernet port of a WAN device for example, an external ADSL modem or cable modem.
- 1 x The Amphenol Connection: used for the connection of Digital Extensions, Analog Trunks (non-b models only), Analog Extensions, Auxiliary Ringer, Page Output, Page Relay, and an alternate Music on

Hold device (if MOH device is connected via amphenol, do not use BCM50 faceplate MOH).

- Music source port: A jack used to connect a music source to the BCM50 Main Unit. If you use this port, the music source connections on the amphenol are disabled.
- 1 x USB connection: USB Port is used for the Startup Profile, Loading Keycode files, Backup/Restore, Patch/software Upgrade (check with your Technical Support as to the appropriate method of patch application).
- Status LED's
- Power Connection
- 1 x cooling fan
- 1 x router card (BCM50e/be only)
- CPU: Motorola PowerQUICC II 8270VR Microprocessor
- RAM: 256MB SDRAM
- Hard Disk: 40 GB Maxtor SATA

### **BCM50be**

The BCM50be main unit provides similar functionality to the BCM50e main unit. The difference is that the BCM50be main unit has two integrated BRI ports replacing the four analog lines on the RJ-21 telephony connector.

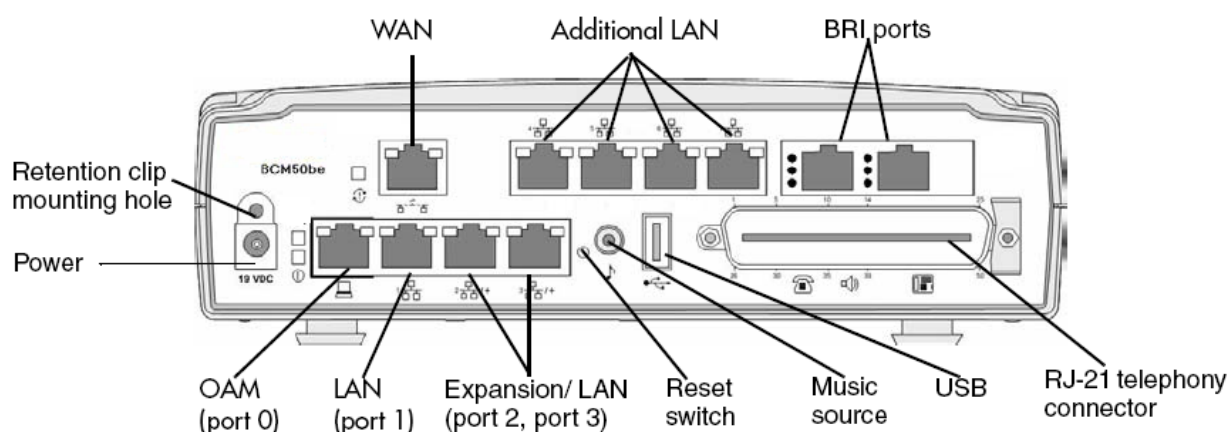

### ***Other Available Features***

BCM50 supports the complete range of IP telephony features and other applications enabled through keycodes without the need for additional hardware:

- VoIP Gateway (H.323): Up to 12 VoIP trunks
- SIP trunks
- VoIP Telephony Clients: Up to 32 VoIP Telephony clients, supporting the range of IP Phones.
- Voice Messaging for voicemail and auto attendant features
- Unified Messaging providing integration between voicemail and email applications
- Fax Suite providing support for attached analog fax devices
- Voice Networking features
- LAN CTE

### ***BCM50 Platform Field Replaceable Items***

The BCM50 field replaceable items are as follows:

- Main Unit itself
- Power Supply
- Hard Drive
- Fan
- Expansion Unit
- Media Bay Modules

Field Replaceable Items – BCM50be only

- Router Card

## BCM50 Additional Components

In addition to the main platforms, the following components are available:

### ***BCM50 Expansion Unit***

This unit is designed to accommodate a media bay module (MBM).

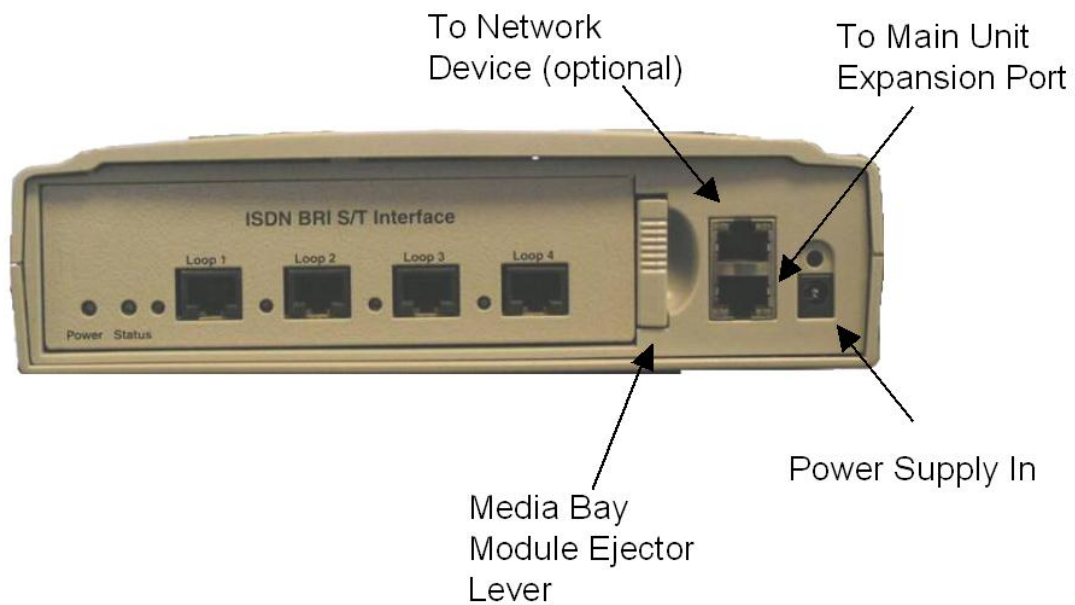

- The BCM50 Main Unit supports up to two BCM50 Expansion Units. There are a maximum of 2 Expansion Units allowed
- Each Expansion Unit can support 1 Media Bay Module

## Flow Chart

The flow chart below describes the BCM50 installation process.

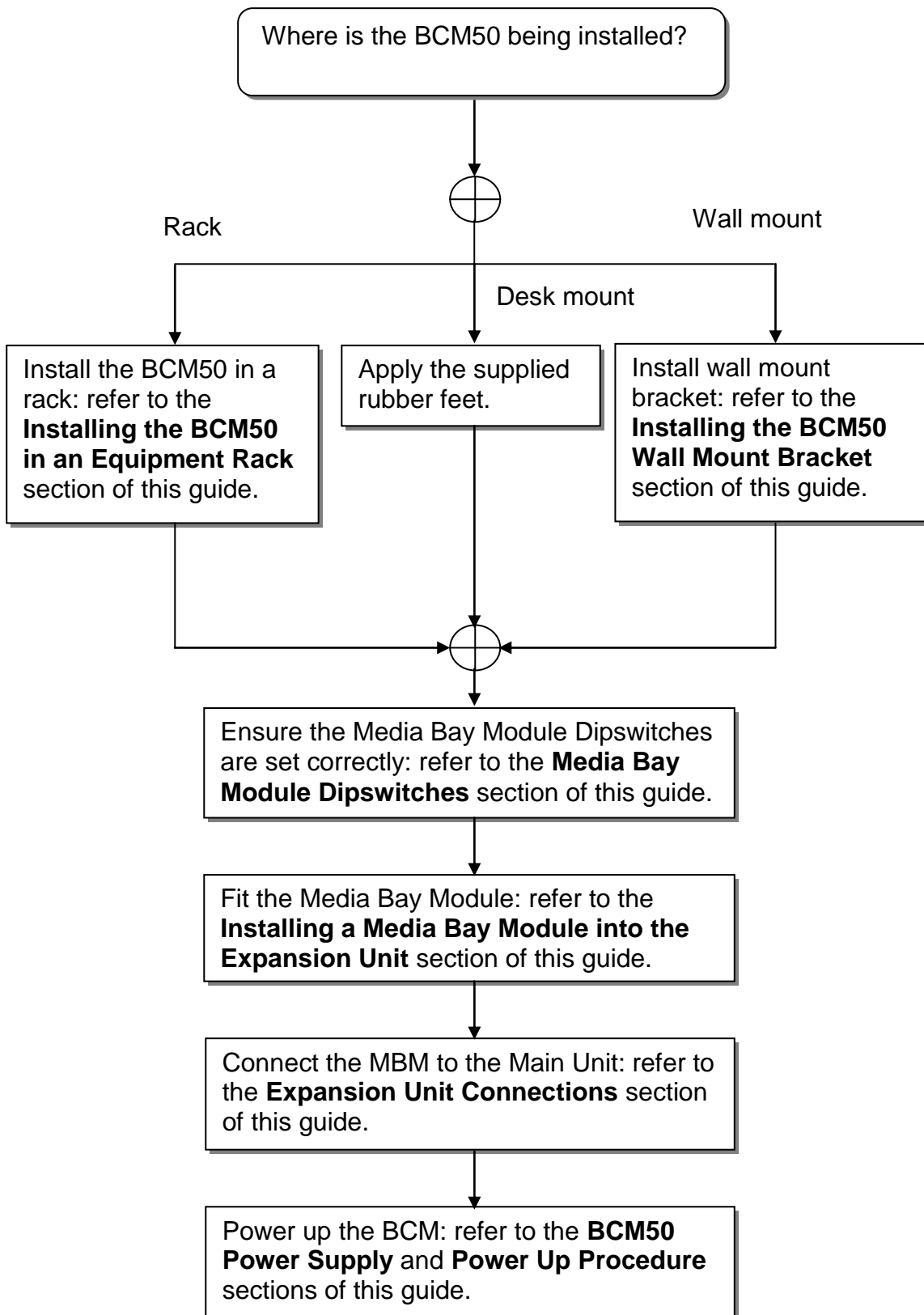

## Wall Mount Bracket

If the BCM50 needs to be mounted on the wall, the wall mounting bracket is required. Each Expansion unit will require it's own bracket. The wall mount bracket includes a cable management tray.

The bracket is designed for mounting the BCM50 Main Unit or BCM50 Expansion Unit to a wall.

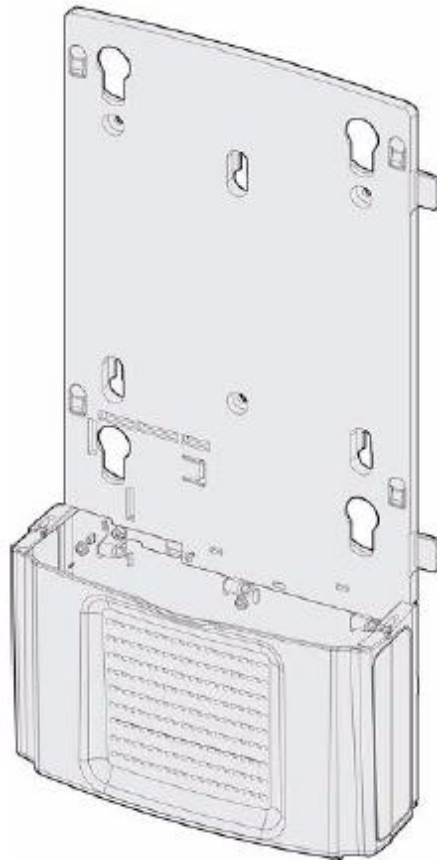

## Rack Mount Shelf

A shelf designed for mounting up to four BCM50 units into a standard 19 inch equipment rack.

- Requires a 19" rack mount shelf
- BCM50 clips into tabs on rack mount shelf
- Expansion unit can clip in next to the Main unit
- 2nd Expansion unit can clip on top of either unit

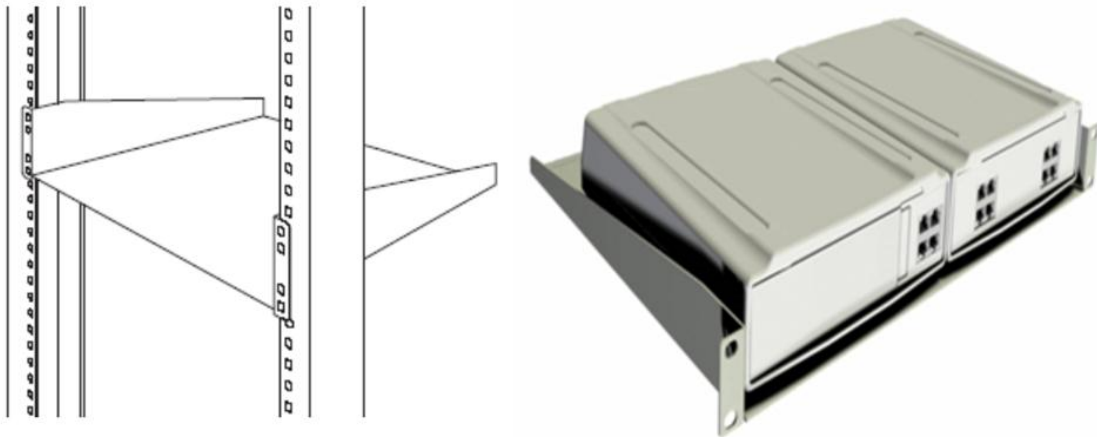

## Desk Mounting the BCM50

Desk Mounting a BCM50 consists of the following:

- Attach the supplied rubber feet
- Clip Expansion units on top of top of other units if required



## Wiring Field Card

An optional wiring field card (WFC) is available with the wall mount bracket, which provides RJ-45 connectors for all BCM50 Main Unit trunk and telephones.

The wiring field card installs into the cable management tray of the wall mount bracket and connects to the telephony connector through a 50-pin header.

The wiring field card contains:

- 12 eight-pin modular jacks for digital stations
- 4 eight-pin modular jacks for analogue trunks
- 4 eight-pin modular jacks for analog stations.
- The eight-pin modular jacks accept RJ-45 or RJ-11 modular plugs.
- There is also a terminal block for connecting auxiliary equipment and a 50-pin header to connect to the BCM50

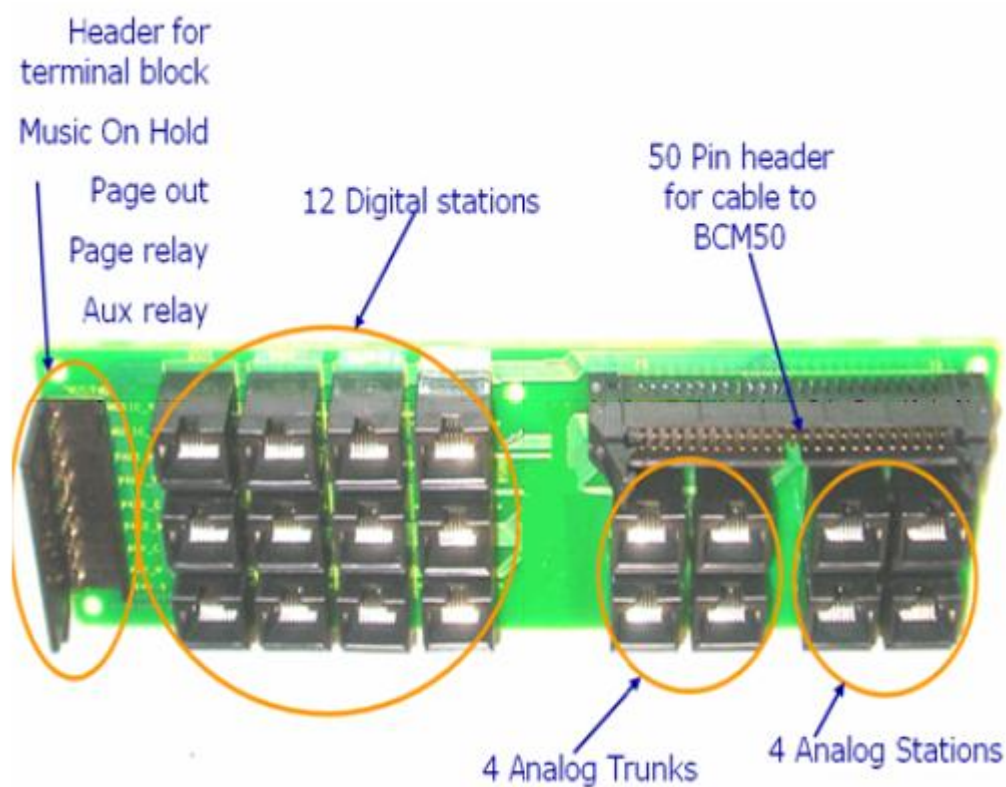

Refer to the **Installing the Wiring Field Card (WFC)** section of this guide for further information.



## Planning the Installation

Before you install the BCM50 Main Unit or BCM50 Expansion Unit, it is good practice to follow a preparation check as follows.

Preparation checklist:

- Number of lines / handsets / ATA2's etc
- Stores check list
- Electrical requirements

Ensure you meet the following electrical requirements:

- Power must be supplied from a non-switched, unobstructed outlet within 1.5 m (5 ft.) of the BCM50 units.
- The supplied power must be a dedicated 220 V to 240 V ac nominal or (110 V to 120 V ac nominal) or 50/60 Hz, 15 A minimum service with a third wire safety ground. The third wire safety ground provides shock protection and prevents electromagnetic interference.
- You can connect the BCM50 power supply to a power bar. The total length of the power cables from the power supply to the electrical outlet (including power bar) must not exceed 2 m (6.5 ft.).
- You must use a power bar approved by an appropriate National Test Body, with a third wire ground.
- Do not use an extension cord between the power supply and the power bar, or between the power bar and the electrical outlet.

**Danger:** Risk of electric shock

The safety of this product requires connection to an outlet with a third wire ground. Use only with the supplied BCM50 power supply and a three wire power outlet.

**Caution:** Check ground connections

Ensure that the electrical ground connections of the power utility, telephone lines, and internal metal water pipe system, if present, are connected together. If these ground connections are not connected together, contact the appropriate electrical inspection authority. Do not try to make the connections yourself.

## ***Environment Checklist***

The installation area must be:

- Minimum of 4 m (13 ft) from equipment such as photocopiers, electrical motors and other equipment that produces electromagnetic, radio frequency and electrostatic interference
- Within 1.5 m (5 ft.) of a three-wire grounded electrical outlet
- Clean, free of traffic and excess dust, dry and well ventilated
- Within the temperature ranges of 0°C and 40°C (32°F and 95°F)
- Between 20% and 80% non-condensing relative humidity
- Enough space and strength to support the BCM base unit
- Minimum of 46 cm (18 in.) from the floor

<p><b>Note:</b> The installation area must be of sufficient height from the floor to prevent water damage.</p>
--

You also need the following equipment to install a BCM50 unit:

- mounting hardware (either a rackmount shelf, a wallmount bracket per unit or four rubber feet per unit)
- Phillips screwdriver #2
- flat blade screwdriver
- pliers
- antistatic grounding strap
- connecting tool
- surge protector (recommended)
- cables, 25-pair cable with RJ-21 connectors

## Installing the BCM50 Unit in an Equipment Rack

You can install a BCM50 unit in the same rack as other networking and telecommunications equipment.

1. Position the rackmount shelf in the rack.
2. Align the holes in the rackmount shelf with the holes in the equipment rack rails.
3. Fasten the rack mount shelf to the rack using the four rack screws

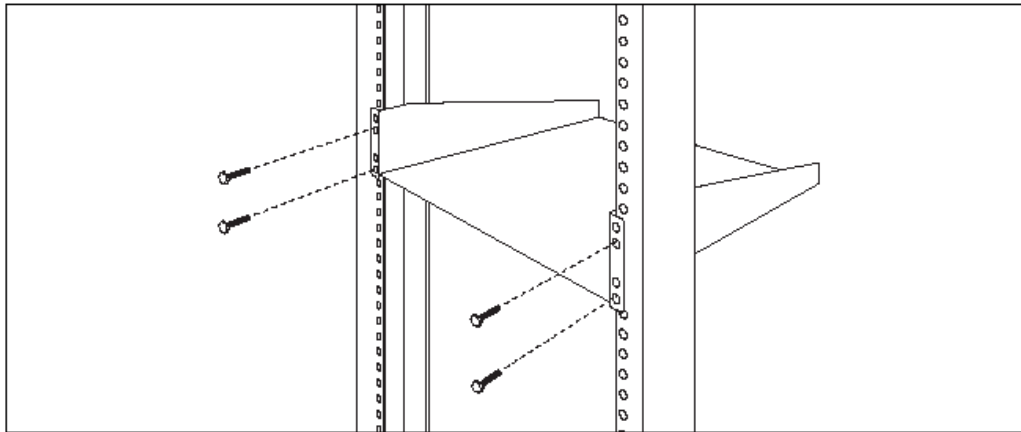

4. Place the BCM50 unit on the rack so that the unit's feet are in the depressions in the shelf.
5. Move the unit forward until the unit's feet touch the front side of the depressions.
6. Slide the unit back until the unit's feet click in place on the tabs in the depressions

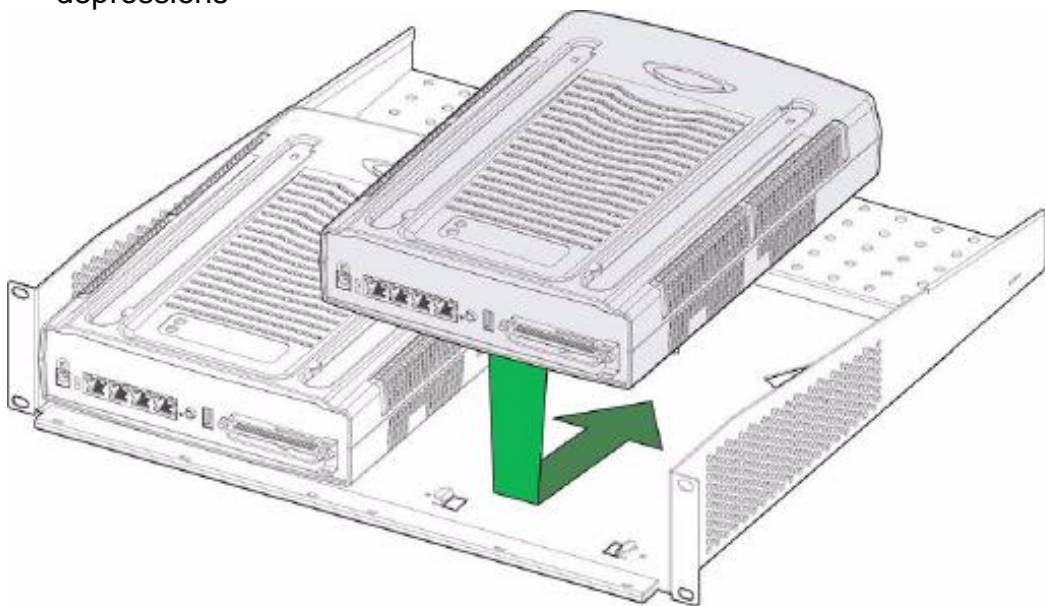

7. If you want to further secure the unit, use four of the self-tapping screws supplied with the rack mount kit to attach the unit to the rack mount shelf. Make sure the screw holes in the unit are aligned with the holes in the rack mount shelf. Then drive the four screws through the holes in the bottom of the shelf and into the screw holes in the bottom of the unit.

## Installing the BCM50 Wall Mount Bracket

1. Place the wall mount bracket on the backboard and mark the location of the center keyhole-shaped screw hole on the plywood backboard
2. Install one #8 x 2 cm (#8 x 0.75 in.) round-head wood screw in the backboard.
3. Do not tighten the screw head against the backboard. Leave approximately 0.5 cm (0.25 in.) of the screw exposed from the backboard.
4. Prepare the wall mount bracket by removing the alignment tabs: If this is the only unit in the BCM50 system, remove the alignment tabs on the right side of the wall mount bracket. If this is the last unit on BCM50 system with multiple units, remove the alignment tabs on the left side of the wall mount bracket.
5. Hang the wall mount bracket on the mounting screw.
6. Use a level to make sure the wall mount bracket is level.
7. Install two #8 x 2 cm (#8 x 0.75 in.) round-head wood screws into the screw holes in the wall mount bracket
8. Tighten the three wood screws against the wall mount bracket.
9. Open the cable management door.
10. Install two #8 x 2 cm (#8 x 0.75 in.) round-head wood screws into the screw holes in the cable trough.
11. If the BCM50 system has more than one unit, place the additional wall mount bracket on the backboard on the right side of the existing wall mount bracket. Use the alignment tabs to ensure the two wall mount brackets are properly aligned.
12. Use three #8 x 2 cm (#8 x 0.75 in.) round-head wood screws to secure the wall mount bracket to the backboard
13. Open the cable management door.

14. Install two #8 x 2 cm (#8 x 0.75 in.) round-head wood screws into the screw holes in the cable trough.
15. Repeat these steps for each additional unit.

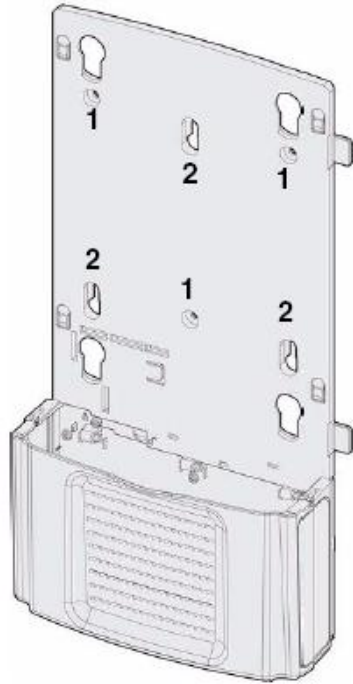

**Note:** When using three screws, Nortel Networks recommends installing the screws in the three holes labeled "1" or the three holes labeled "2".

16. Insert the power supply retention clip into the BCM50 unit.
17. Slide the wall mount lock fully to the right (unlock position).

18. Align the feet on the BCM50 unit with the four holes in the wall mount bracket

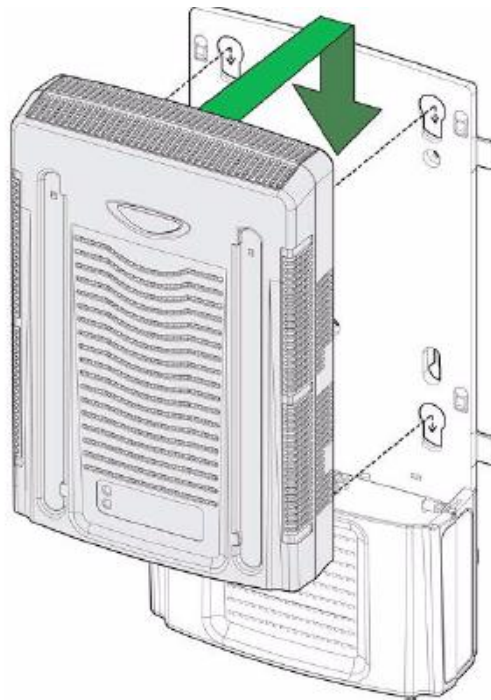

19. Press the unit against the wall mount bracket and slide the unit down until it clicks in place.
20. Slide the wall mount lock to the left (lock position).
21. Use the supplied screw to secure the wall mount lock in position.
22. Repeat steps 1 to 6 for each additional BCM50 unit you are installing.
23. Install the BCM50 power supply using a method appropriate for your environment.
24. The power supply must be within 1.5 m (5 feet) of the BCM50 unit and within 1.5 m (5 feet) of the ac power outlet (wall outlet or UPS).
25. Repeat step 8 for each BCM50 power supply.

## Installing a BCM50 Expansion Unit

Adding a BCM50 Expansion Unit increases the capacity of the BCM50 system by providing a method of adding a media bay module (MBM). Each MBM you add increases the number of trunks or extensions that you can connect to the BCM50 system.

- There are a maximum of 2 Expansion Units allowed
- Each Expansion Unit can support 1 Media Bay Module
- There is no bus sharing allowed (as on the BCM200/400)

### ***Supported Media Bay Modules***

The following Media Bay Modules are supported on the BCM50:

- Digital Trunk Modules:
  - DTM (digital trunk module)
  - BRI (ISDN Basic Rate trunk module)
- Analog Trunk Modules
  - CTM4/8 (4/8-port analog CLID trunk module)
  - GATM4/8 (global 4/8-port analog trunk module)
  - ADID4/8 (4/8-port analog direct inward dial)
- Digital Station Modules
  - DSM16(+)/32(+) (16/32-port digital station module)
- Analog Station Modules
  - ASM8/8+ (8-port analog station interface)
  - GASM8 (global 8-port analog station interface)
- Combination Modules
  - 4/8x16 Combo (4/8 analog trunks, 16 digital stations, combination of CTM4/8 & DSM16)
  - G4/8x16 Combo (global 4/8 analog trunks, 16 digital stations, combination of GATM4/8 & DSM16)
- Special Modules
  - R2MFC

## Media Bay Module Descriptions

The following sections describe the hardware attributes and functionality of the Media Bay Modules.

### Digital Trunk Module

When configured on a North American BCM system, the DTM connects a T1 or PRI circuit to the BCM system; T1 circuits provide 24 digital channels to the PSTN, while PRI circuits provide 23 digital channels to the PSTN.

When configured on an International BCM system, the DTM connects an ETSI ISDN (E1) or PRI (E1) circuit to the BCM system, providing a maximum of 30 digital channels to the PSTN.

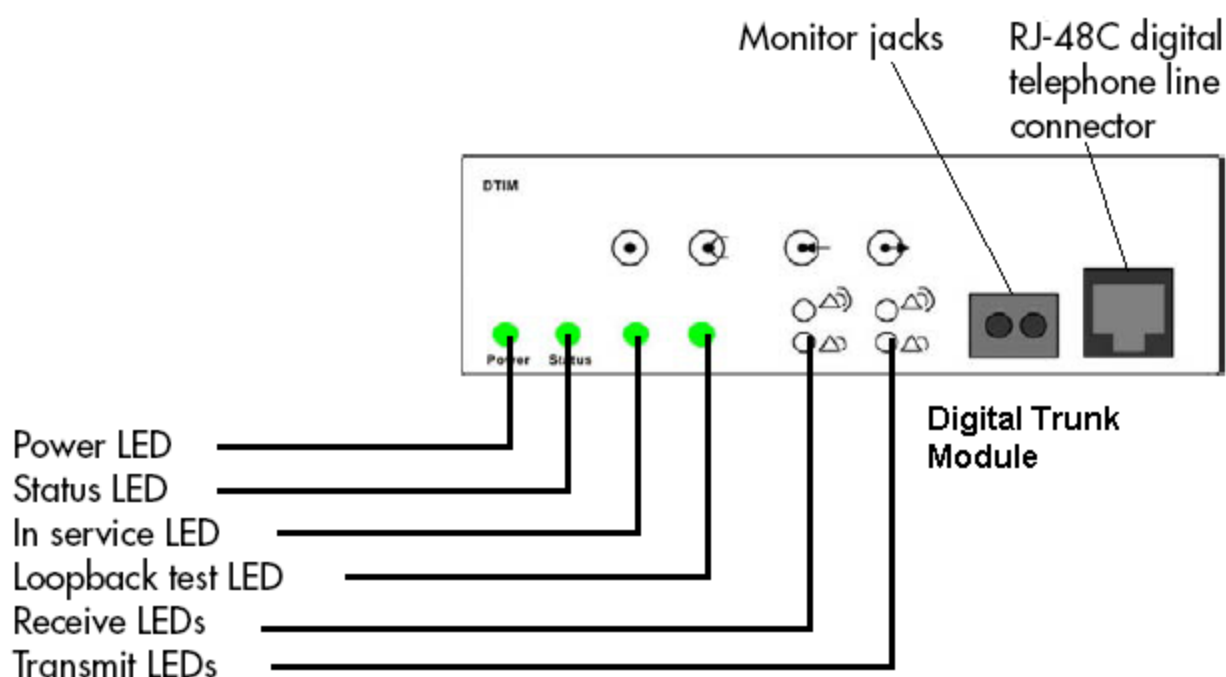

### Caller ID Trunk Module

There are two types of Caller ID trunk media bay modules (CTM):

#### 1. CTM4:

The CTM4 connects a maximum of four analog calling line ID (CLID) interfaces to the BCM system through four RJ-11 jacks on the front faceplate of the MBM. These jacks are labelled Line 1, Auxiliary, Line 2, Line 3, and Line 4. The auxiliary jack connects to Line 1.



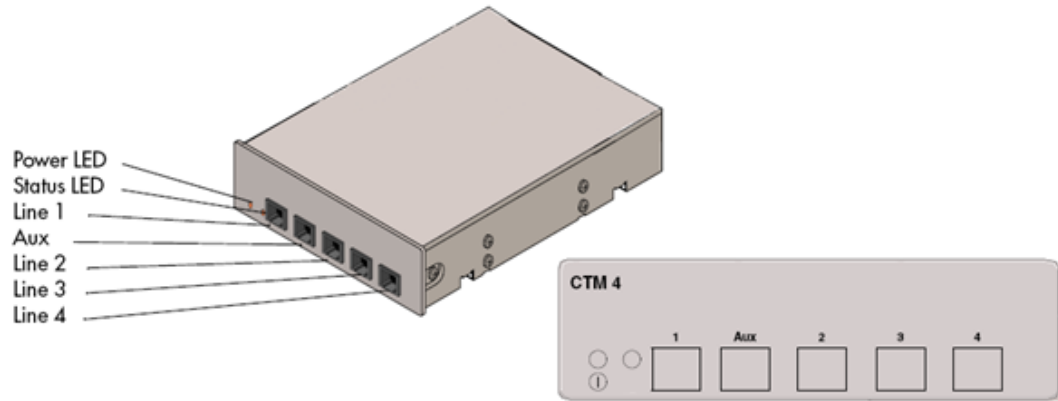

**2. CTM8:**

The CTM8 provides eight analog CLID interfaces to the BCM system through eight RJ-11 jacks on the front faceplate of the BCM. Each jack also supports disconnect supervision. There are two auxiliary jacks on this MBM which connect to Line 1 and Line 5.

The auxiliary ports will interface to a V.92 or V.90 modem, fax machine unit, or analog telephone. When the auxiliary device is active, the BCM system disables the associated line. If the line is active, the auxiliary port line is disabled.

When an analog telephone is connected to the auxiliary port, it can be used as an emergency telephone because this line remains active during a power outage.

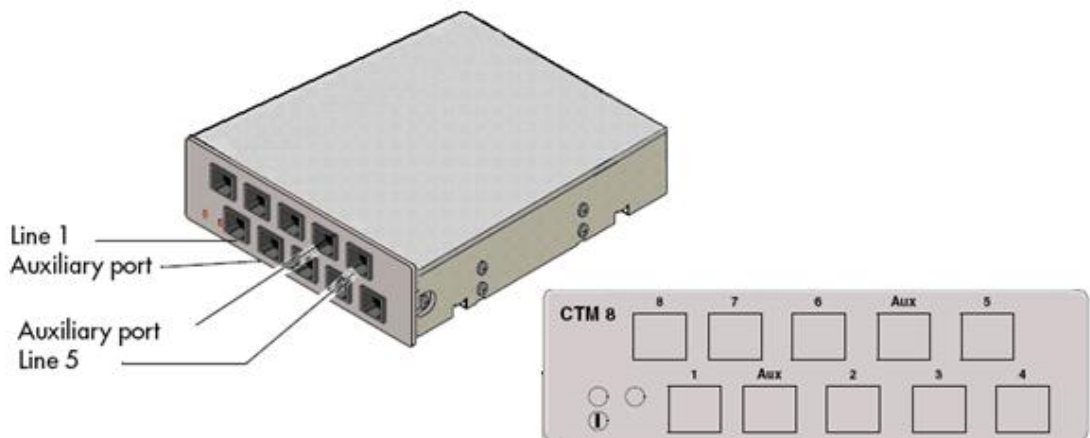

### **Basic Rate Interface Module**

The Basic Rate Interface media bay module (BRIM) connects a maximum of four BRI ISDN loops to the BCM system.

The BRIM only recognizes the T-interface used in European networks. To use the BRIM with the U-interface, typical in North American networks, you require an external NT1 box to convert the U-interface to a T-interface.

Each BRI ISDN connected loop adds two telephone lines to the BCM system. Each BRIM can add a maximum of eight lines to the BCM system through the four RJ-48C jacks on the faceplate.

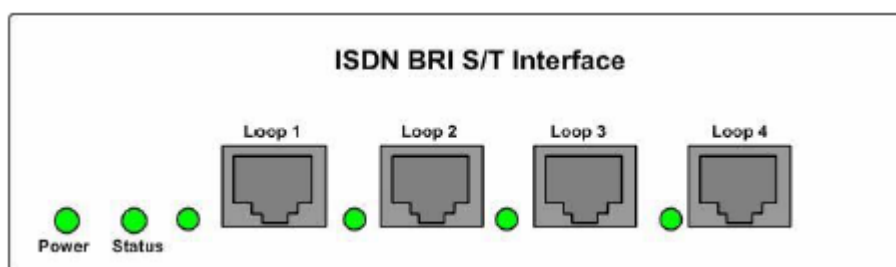

### **Global Analog Trunk Module**

The global analog trunk media bay module (GATM) provides an interface for four or eight analog public switched telephone network (PSTN) lines. The GATM supports both pulse and tone dialing, as well as caller ID and disconnect supervision in selected markets throughout the world. The GATM uses an RJ-21 connector as the trunk interface.

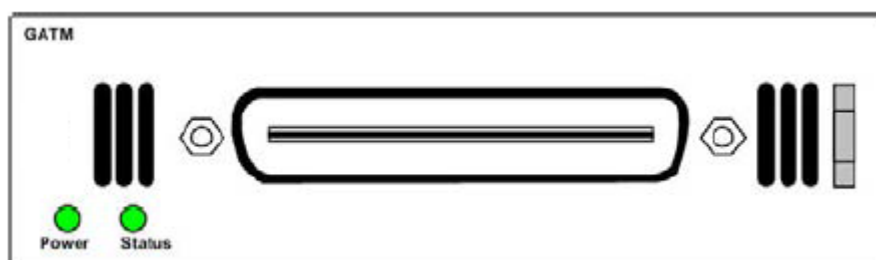

### Digital Station Module

The digital station media bay modules (DSM) support digital telephones on the BCM system.

DSM16(+): supports 16 digital telephones through one RJ-21 connector.

DSM32(+): supports 32 digital telephones through two RJ-21 connectors.

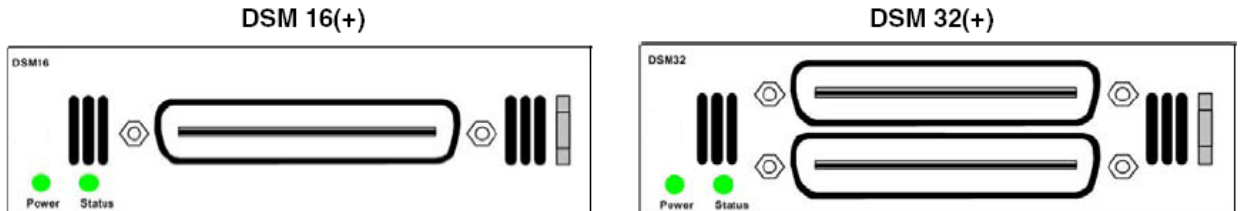

### Analog Station Media Modules

The analog station media bay modules (ASM, ASM8, ASM8+, and GASM8) can connect to a maximum of eight analog telecommunication devices. These devices are standard analog telephones, cordless telephones, fax machines, answering machines, or modems.

In addition to ASM8 features, the ASM8+ and GASM8 offer the following features:

- Visual Message Waiting Indicator (VMWI) — LED indicates that a message is waiting.
- Disconnect supervision (Open Switch Interval [OSI] as per EIA/TIA 464). Indicates to the attached device, in an established communication, that the connected device should release the call
- Caller ID — provides the name, phone number, and other information about the caller to the end user telephone at the start of the call.
- Firmware downloading capability — allows the system to upgrade the ASM8+ and GASM8 firmware.
- Enhanced ringing capability — ASM8+ and GASM8 provide a ringing voltage of 2 REN/65 V rms per port.
- Calling line identification (CLID)
- The GASM8 is designated as an ONS (on-premise station) port.

### GASM8 faceplate LEDs and connectors

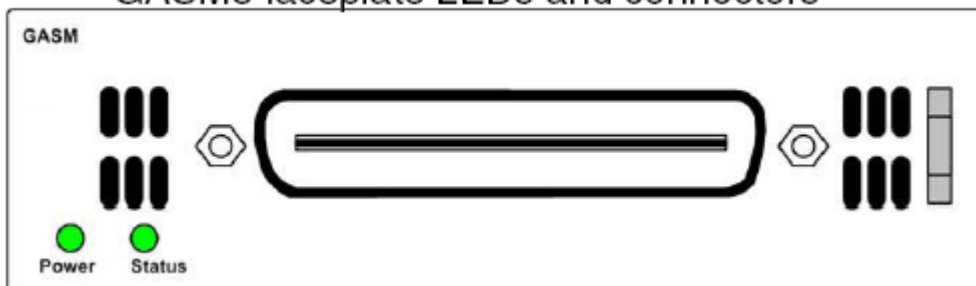

### 4x16 Media Bay Module

The 4x16 media bay module (MBM) provides both analog trunk and digital telephone connections. The 4x16 MBM provides connections for four analog lines and 16 digital telephones. Each of the four analog lines support caller ID and disconnect supervision. An auxiliary port next to the Line 1 port enables you to use an analog telephony device, such as a modem, fax, or telephone, to share the trunk.

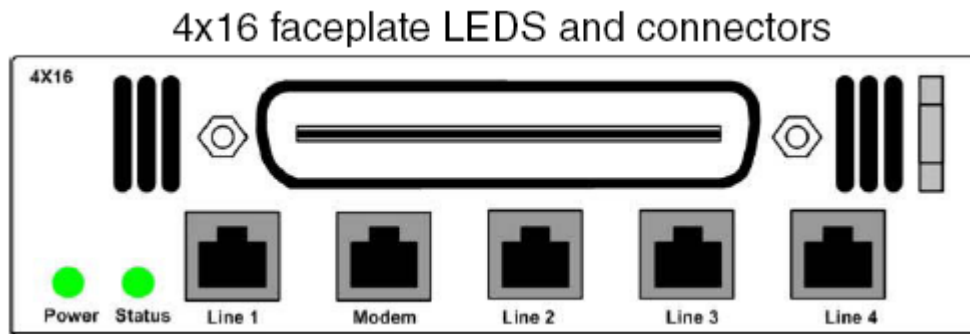

### Global 4x16 and Global 8x16 Module

This is a combination module that provides 16 Digital Extensions and either 4 or 8 analog lines (version dependant). It will utilise two DS30 buses one for the lines the other for the extensions. For example, if dipswitches are set to use bus 4 the analog trunks will use bus 4 and the DSM16 element will use bus 5.

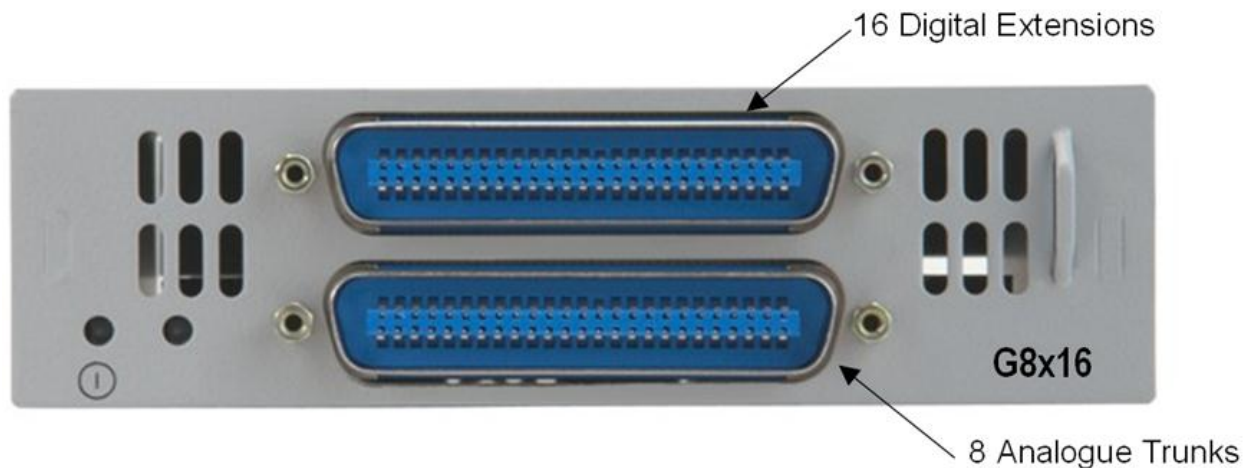

## Media Bay Module Dipswitches

Each media bay module (MBM) has a set of dipswitches on the back or underside of the MBM

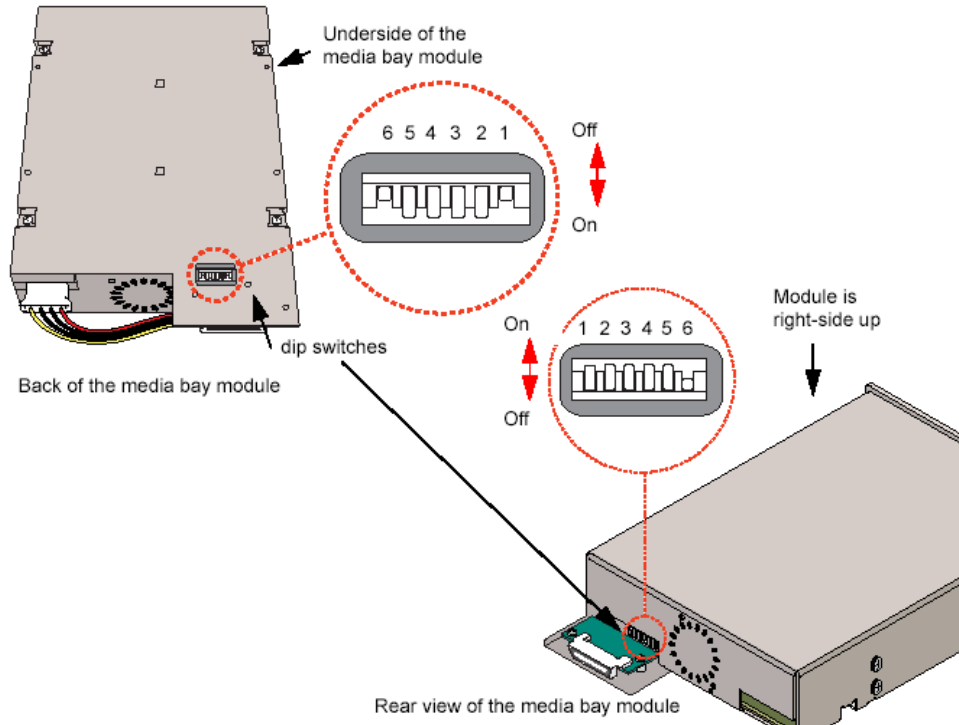

If you are installing a DTM, BRIM, CTM4/8, ADID4/8, 4x16, DSM16/32(+), or ASM8, ensure that all the switches are on. This is the default setting for the MBM switches.

The exceptions to this are the GASM (Analog extensions), GATM (Analog Lines), and G4/8x16 modules. The settings below refer to the switches on the right hand side of the **GASM** Media Bay Module. For the dip switches on the left side, set all the switches to on.

### GASM right hand side dipswitch settings (switch 1-3)

Switch	Description	Setting
Switch 1	Firmware download capability	OFF — Standard mode (firmware downloading not supported) ON — Enhanced mode (firmware downloading supported)
Switch 2	Set when the firmware is downloaded from the BCM50 (for enhanced mode only)	OFF — if you want the GASM8 to download the firmware when the firmware version in the BCM50 is different than the version in the GASM8 (default) ON — if you want the GASM8 to download the firmware whenever there is a cold start of the BCM50
Switch 3	Enable/disable echo cancellation	OFF — Enables echo cancellation (default) ON — Disables echo cancellation

### GASM right hand side dipswitch settings (switch 4–8)

Switches 4 to 8 select the region for the GASM8 as follows:

	Switch 4	Switch 5	Switch 6	Switch 7	Switch 8
North America	OFF	OFF	OFF	OFF	OFF
United Kingdom	OFF	OFF	OFF	OFF	ON
Australia	OFF	OFF	OFF	ON	OFF
Poland	OFF	OFF	OFF	ON	ON

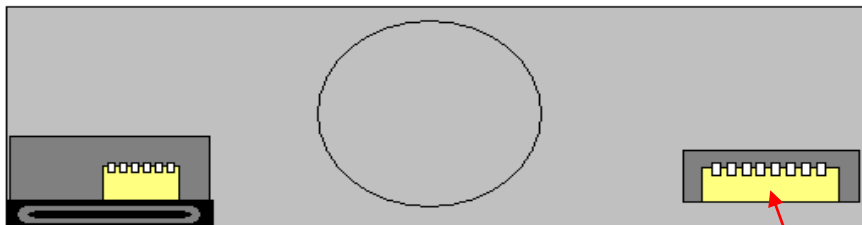

Country Profile dip switches

### GATM & G4/8x16 dipswitch settings

For the dip switches on the left side, at the rear of the module, set all the switches to on. For the dip switches on the right side, at the rear of the module (country profile switches), set all of the switches to off. The module downloads the country profiles automatically.

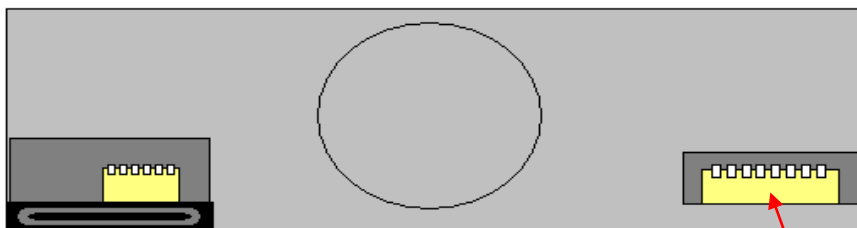

Country Profile dip switches

### Installing a Media Bay Module into the Expansion Unit

1. Ensure that you use an anti-static strap for the installation.
2. Expansion Units are not supplied with blanking plates





3. Insert the Media Bay Module into the unit. You hear a click when the MBM is firmly seated in the BCM50 Expansion Unit.



4. For MBM removal, pull the ejector lever away from the unit

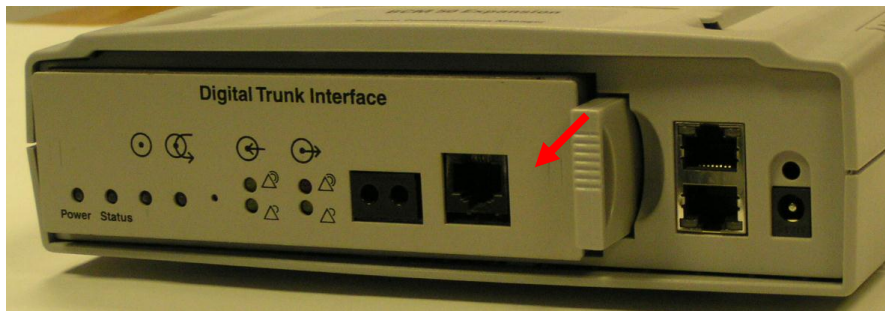

The BCM50 Expansion Unit can be mounted in a rack, on a wall, or on a desktop. Typically, the BCM50 Expansion Unit is mounted in the same way that the Main Unit was mounted.

### ***Expansion Unit Connections***

The supplied ethernet cable connects the expansion port on the BCM50 Expansion Unit to one of the two expansion ports on the BCM50 Main Unit.

If the BCM50 system has a BCM50 Expansion Unit, perform the following procedure:

- Locate the expansion cable that was supplied with the BCM50 Expansion Unit.

**Note:** If you do not have the expansion cable, you can use a shielded category 5e-compliant Ethernet cable (maximum length of 10 m).

- Plug one end of the expansion cable into the expansion port on the BCM50 Expansion Unit.

- Plug the other end of the expansion cable into one of the expansion ports on the BCM50 Main Unit

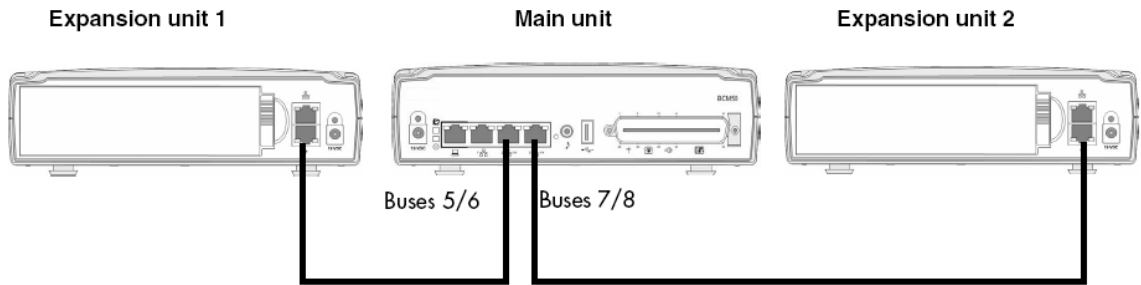

The LAN port on the BCM50 Expansion Unit is connected to the internal ethernet switch on the BCM50 Main Unit. You can use the BCM50 Expansion Unit LAN port to connect an additional device to the LAN

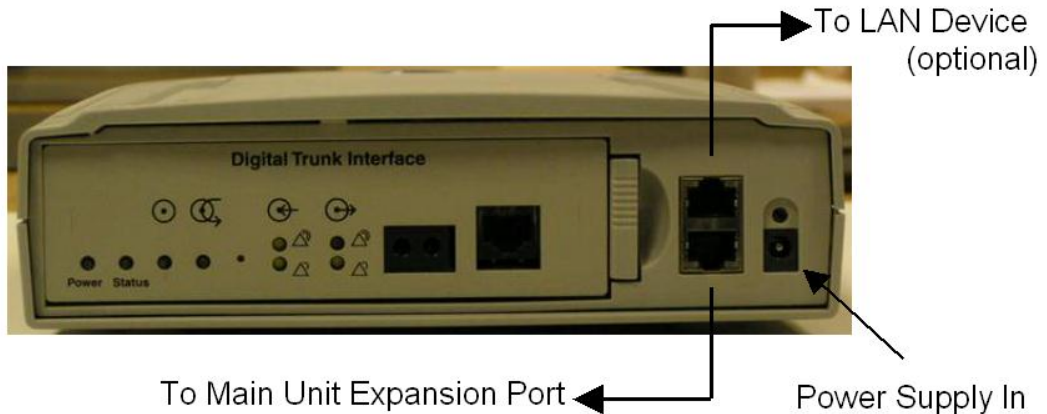

The expansion port you select determines the line and extension numbers of the devices connected to the BCM50 Expansion Unit.



**Bus Assignment**

Bus assignment is not dependant on Dip Switch settings. The Expansion Port determines bus assignment.

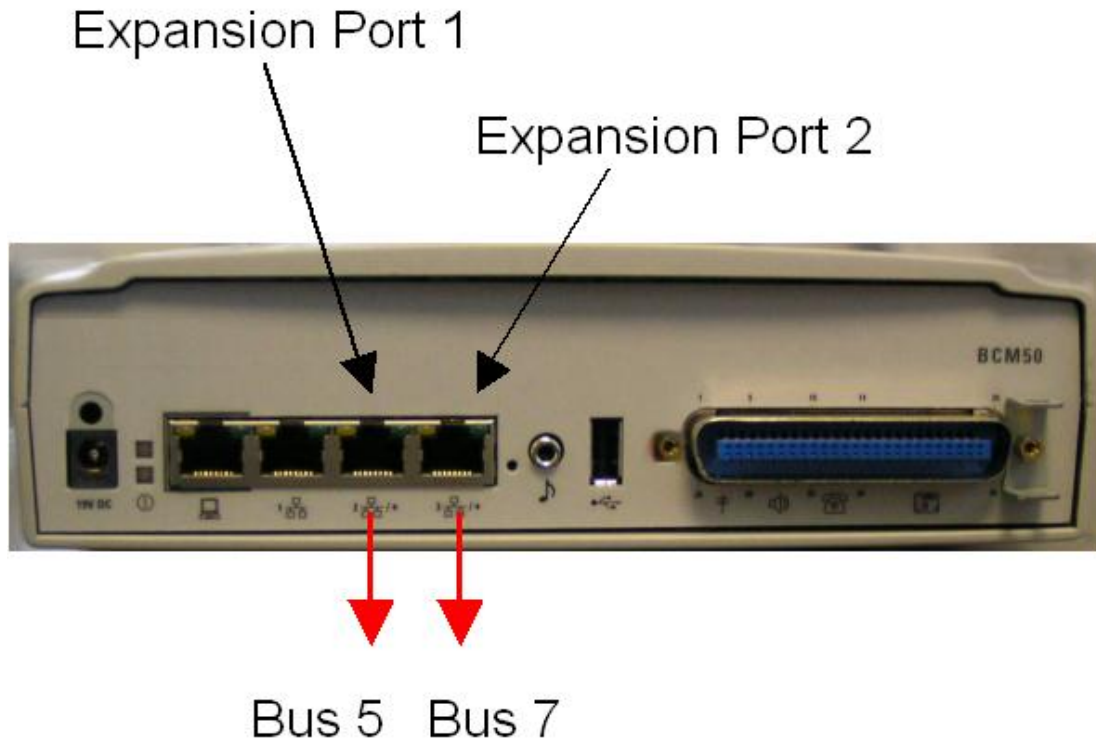

**Bus Utilisation**

Bus Number	Type	Function
1	Internal	IP & Application Sets
N/A	Internal	IP Trunks
3	Internal	Analogue Trunks or if model is BCM50b/50be, then BRI Trunks
4	Internal	Onboard Digital/Analog Sets
5	External	Trunks/Sets via MBM's
6	External	Sets (only enabled when using DSM32(+) or (G)4/8x16 on bus 5)
7	External	Trunks/Sets via MBM's
8	External	Sets (only enabled when using DSM32(+) or (G)4/8x16 on bus 7)

### ***Bus Assignment & Default Line Numbers***

Bus Number	Type/Function	Line Numbers	
N/A	Internal IP Trunks	1 - 12	
3	Internal Analogue/BRI	61 - 64	
5	External	GATM4	65 - 68
		GATM8	65 - 68 & 73 - 76
		BRI	65 - 72
		DTM	65 - 94
		ADID4	65 - 68
		ADID8	65 - 68 & 73 - 76
		(G)4x16 Combo	65 - 68
		(G)8x16 Combo	65 - 68 & 73 - 76
7	External	GATM4	95 - 98
		GATM8	95 - 98 & 103 - 106
		BRI	95 - 102
		DTM	95 - 124
		ADID4	95 - 98
		ADID8	95 - 98 & 103 - 106
		(G)4x16 Combo	95 - 98
		(G)8x16 Combo	95 - 98 & 103 - 106

### ***Line Numbering Plan***

Line Type	Line Number
VoIP Trunks	001 - 012
Internal Analogue Physical Trunks Or BRI Trunks (BCM 50 b/be models)	061-064
External Physical Trunks	065 - 124
Target Lines	125 - 268

**Bus Assignment & Default DN Numbers**

Bus Number	Type	Port Numbers	DN Numbers (assuming Default Start DN =221)
1			
4	Internal	Digital	401 - 412
	Internal	Analog	413 - 416
5	External	DSM 16+	501 - 516
		DSM 32+(low)	501 - 516
		ASM/ASM+	501 - 516
6	External	DSM32+ (high)	601 - 616
6	External	(G)4/8 x 16 Combo	601 - 616
7	External	DSM16+	701 - 716
		DSM32+(low)	701 - 716
		ASM/ASM+	701 - 716
8	External	DSM32+ (high)	801 - 816
8	External	(G)4/8 x 16 Combo	801 - 816

**Note:** Buses 6 & 8 only appear if assigning a DSM32+ or (G)4/8 x 16 combo to buses 5 & 7.

## Wiring Charts

### *Main Unit Amphenol Wiring*

Ideally, extensions should be wired to a patch strip. The BCM50 Patch Panel allows direct connection to the amphenol cable via a 50-pin header. This BCM50 Patch Panel is designed for connection to the Main Unit. If standard Patch Panels/wiring equipment are to be used, the amphenol wiring scheme is as below

Device	Pin	Connection	Wire Colour	Type of Device	Default DN Number	Default Line Number
1	26 1	Tip Ring	White-Blue Blue-White	Analog Line	-	061
2	27 2	Tip Ring	White-Orange Orange-White	Analog Line	-	062
3	28 3	Tip Ring	White-Green Green-White	Analog Line	-	063
4	29 4	Tip Ring	White-Brown Brown-White	Analog Line	-	064
5	30 5	Tip Ring	White-Slate Slate-White	Analog Telephone	233	-
6	31 6	Tip Ring	Red-Blue Blue-Red	Analog Telephone	234	-
7	32 7	Tip Ring	Red-Orange Orange-Red	Analog Telephone	235	-
8	33 8	Tip Ring	Red-Green Green-Red	Analog Telephone	236	-
9	34 9	Tip Ring	Red-Brown Brown-Red	No Connection	-	-
10	35 10	Tip Ring	Red-Slate Slate-Red	Auxiliary Ringer	-	-
11	36 11	Tip Ring	Black-Blue Blue-Black	Page Relay	-	-
12	37 12	Tip Ring	Black-Orange Orange-Black	Page Output	-	-
13	38 13	Tip Ring	Black-Green Green-Black	Music Source	-	-
14	39 14	Tip Ring	Black-Brown Brown-Black	Digital Telephone	232	-
15	40 15	Tip Ring	Black-Slate Slate-Black	Digital Telephone	231	-
16	41 16	Tip Ring	Yellow-Blue Blue-Yellow	Digital Telephone	230	-
17	42 17	Tip Ring	Yellow-Orange Orange -Yellow	Digital Telephone	229	-
18	43 18	Tip Ring	Yellow -green Green- yellow	Digital Telephone	228	-
19	44 19	Tip Ring	Yellow-Brown Brown-Yellow	Digital Telephone	227	-
20	45 20	Tip Ring	Yellow-Slate Slate Yellow	Digital Telephone	226	-
21	46 21	Tip Ring	Violet- Blue Blue -Violet	Digital Telephone	225	-
22	47 22	Tip Ring	Violet-Orange Orange-Violet	Digital Telephone	224	-
23	48 23	Tip Ring	Violet- Green Green-Violet	Digital Telephone	223	-
24	49 24	Tip Ring	Violet-Brown Brown -Violet	Digital Telephone	222	-
25	50 25	Tip Ring	Violet-Slate Slate-Violet	Digital Telephone	221	-

**Note:** The wiring scheme relates to the main unit amphenol connection only. If connecting to a station media bay module (e.g. DSM 16+/32+), the first extension is wired to the first device pair in the table above (i.e. Blue/White).

### **ASM8(+)/GASM/DSM(+) Media Bay Module Amphenol Wiring**

Use the table below if connecting extensions (stations) to a DSM Media Bay Module.

Device	Pin	Connection	Wire Colour	Expansion Port 1		Expansion Port 2	
				ASM8/GASM DSM16/ DSM 32 Low Default DN's	DSM 32 High Def. DN's	ASM8/GASM DSM 16/ DSM32 Low Def. DN's	DSM 32 High Def. DN's
<b>ASM8/GASM/DSM</b>							
1	26 1	Tip Ring	White-Blue Blue-White	237	253	269	285
2	27 2	Tip Ring	White-Orange Orange-White	238	254	270	286
3	28 3	Tip Ring	White-Green Green-White	239	255	271	287
4	29 4	Tip Ring	White-Brown Brown-White	240	256	272	288
5	30 5	Tip Ring	White-Slate Slate-White	241	257	273	289
6	31 6	Tip Ring	Red-Blue Blue-Red	242	258	274	290
7	32 7	Tip Ring	Red-Orange Orange-Red	243	259	275	291
8	33 8	Tip Ring	Red-Green Green-Red	244	260	276	292
<b>DSM Only</b>							
9	34 9	Tip Ring	Red-Brown Brown-Red	245	261	277	293
10	35 10	Tip Ring	Red-Slate Slate-Red	246	262	278	294
11	36 11	Tip Ring	Black-Blue Blue-Black	247	263	279	295
12	37 12	Tip Ring	Black-Orange Orange-Black	248	264	280	296
13	38 13	Tip Ring	Black-Green Green-Black	249	265	281	297
14	39 14	Tip Ring	Black-Brown Brown-Black	250	266	282	298
15	40 15	Tip Ring	Black-Slate Slate-Black	251	267	283	299
16	41 16	Tip Ring	Yellow-Blue Blue-Yellow	252	268	284	300
17 - 25	No Connection						

**Note:** The ASM8/8+ and GASM MBM's support 8 analog stations.

## ***ADID4/8 Media Bay Module Amphenol Wiring***

Use the table below if connecting analog trunks to an Analog Direct Inward Dial MBM.

Device	Pin	Connection	Wire Colour	Expansion Port 1 Default Line Numbers	Expansion Port 2 Default Line Numbers
<b>ADID4 &amp; ADID8</b>					
1	26 1	Tip Ring	White-Blue Blue-White	065	095
2	27 2	Tip Ring	White-Orange Orange-White	066	096
3	28 3	Tip Ring	White-Green Green-White	067	097
4	29 4	Tip Ring	White-Brown Brown-White	068	098
<b>ADID8 Only</b>					
5	30 5	Tip Ring	White-Slate Slate-White	073	103
6	31 6	Tip Ring	Red-Blue Blue-Red	074	104
7	32 7	Tip Ring	Red-Orange Orange-Red	075	105
8	33 8	Tip Ring	Red-Green Green-Red	076	106

## ***GATM4/8 Media Bay Module Amphenol Wiring***

Use the table below if connecting analog trunks to a GATM4 or GATM8 Media Bay Module. It is also possible to connect a power fail extension to the last pair on the amphenol wiring.

<b>Device</b>	<b>Pin</b>	<b>Connection</b>	<b>Wire Colour</b>	<b>Expansion Port 1 Default Line Numbers</b>	<b>Expansion Port 2 Default Line Numbers</b>
<b>GATM4 &amp; GATM8</b>					
1	26 1	Tip Ring	White-Blue Blue-White	065	095
2	27 2	Tip Ring	White-Orange Orange-White	066	096
3 – 4	No Connection				
5	30 5	Tip Ring	White-Slate Slate-White	067	097
6	31 6	Tip Ring	Red-Blue Blue-Red	068	098
<b>GATM8 Only</b>					
7 – 8	No Connection				
9	34 9	Tip Ring	Red-Brown Brown-Red	073	103
10	35 10	Tip Ring	Red-Slate Slate-Red	074	104
11 - 12	No Connection				
13	38 13	Tip Ring	Black-Green Green-Black	075	105
14	39 14	Tip Ring	Black-Brown Brown-Black	076	106
15 - 24	No Connection				
25	50 25	Tip Ring	Violet-Slate Slate-Violet	Can be used to connect a power fail analog set. If system power fails the set will use line 1.	

## G4/8x16 Media Bay Module Amphenol Wiring

The G4/8x16 MBM's is a combination of the GATM4/8 and DSM16(+) Media Bay Modules.

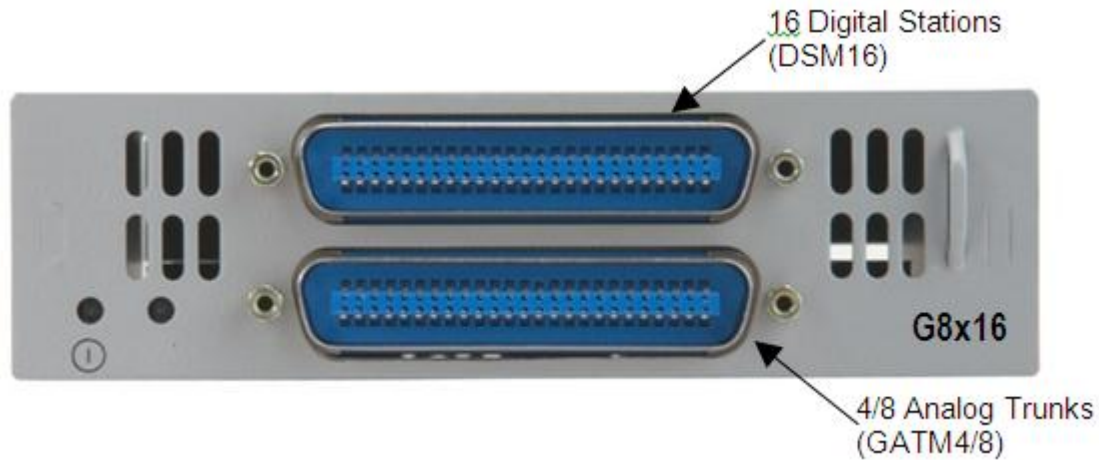

For the Analog Trunk wiring, refer to the **GATM4/8 Media Bay Module Amphenol Wiring** section of this guide.

For the Digital Station wiring, refer to the **ASM/GASM/DSM Media Bay Module Amphenol Wiring** section of this guide, consulting the DSM32 High column(s).

## 4x16 Media Bay Module Wiring

The 4x16 MBM has RJ-11 ports for connecting Analog Trunks, and an amphenol connection for connecting the Digital Stations. The RJ-11 pin outs are as below.

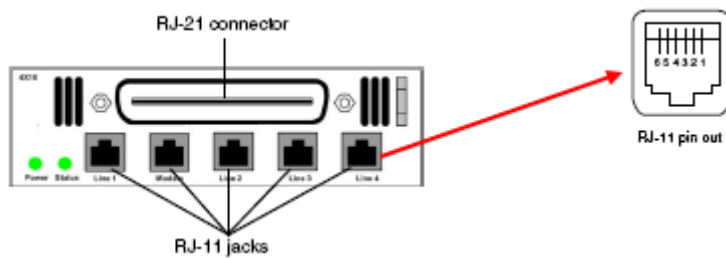



There are 4 line ports for analog trunks, and an auxiliary port next to Line port 1 designated for an emergency (power fail) phone.

Pin	Signal
1	No connection
2	No connection
3	Ring
4	Tip
5	No connection
6	No connection

Line Port	Expansion Port 1 Default Line Number	Expansion Port 2 Default Line Number
1	065	095
2	066	096
3	067	097
4	068	098

For the Digital Station wiring, refer to the **ASM/GASM/DSM Media Bay Module Ampenol Wiring** section of this guide, consulting the DSM32 High column(s).

### BRI Ports

The below BRI Port Wiring chart relates to the onboard BRI ports on BCM50b/be models, and also to the BRI Media Bay Modules.

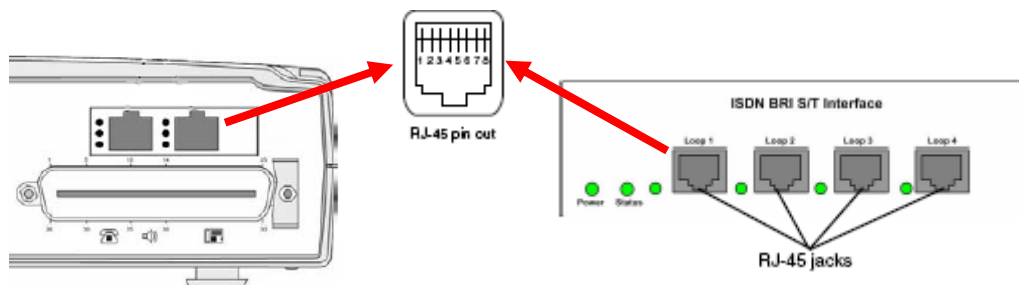

## BRI Port Wiring

Pin	Signal	Signal on system side
1	No connection	No connection
2	No connection	No connection
3	+ Receive (+Rx)	+Tx
4	+ Transmit (+Tx)	+Rx
5	- Transmit (-Tx)	-Rx
6	- Receive (-Rx)	-Tx
7	No connection	No connection
8	No connection	No connection

Onboard BRI Ports Default Line Numbers		
1	061-062	
2	063-064	
Expansion Port Default Line Numbers		
BRIM Port	Expansion Port 1 Default Line Numbers	Expansion Port 2 Default Line Numbers
1	065-066	095-096
2	067-068	097-098
3	069-070	099-100
4	071-072	101-102

## DTM Ports

The digital trunks are connected to the DTM via the RJ-48C jack.



The pin outs are detailed below.

Pin	Signal
1	Receive Ring
2	Receive Tip
3	Receive Shield
4	Transmit Ring
5	Transmit Tip
6	Transmit Shield
7	No connection
8	No connection

Trunk Type	Expansion Port 1 Default Line Numbers	Expansion Port 2 Default Line Numbers
E1	065-094	095-124
T1	065-088	095-118
PRI	065-087	095-117

## BCM50 Power Supply

The BCM50 power supply is an external device that connects to the BCM50 units. You must have one power supply for each unit you have in your BCM50 system

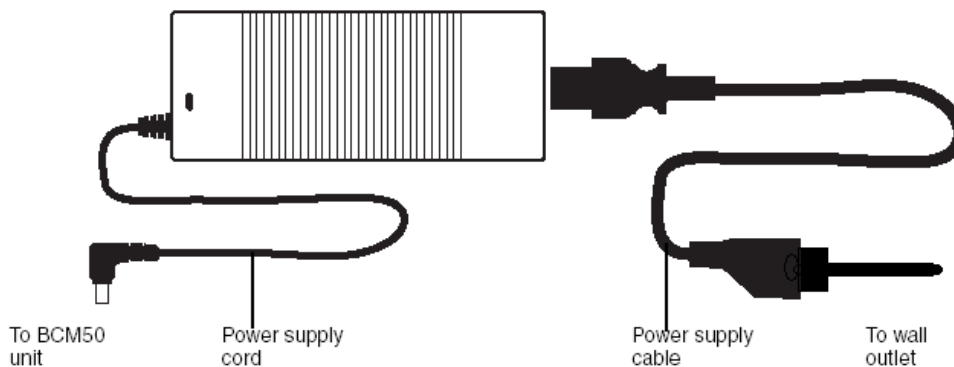

An uninterruptible power supply (UPS) is an optional device that you connect to your BCM50 system. The UPS provides battery backup for the BCM50 system to maintain continuous operation during power interruption or failure conditions.

**Note:** For the UPS to function correctly, it must be connected before the BCM50 system is powered up. If you connect a UPS to a running system, the UPS does not function.

### Connecting a Power Supply Using a UPS

1. Mount the UPS within 1.5 meters (5 feet) of the BCM50 units.
2. The UPS must be close enough to the BCM50 units that the power supply can be connected to both the UPS and the BCM50 units.
3. Plug one end of the USB cable into the USB port on the UPS.
4. For information about the location of the ports on the UPS, refer to the UPS documentation.
5. Plug the other end of the USB cable into the USB hub.
6. Plug one end of the second USB cable into the USB hub.
7. Plug the other end of the second USB cable into the USB port on the main unit.

8. Plug the UPS power cord into the ac power source (wall outlet).

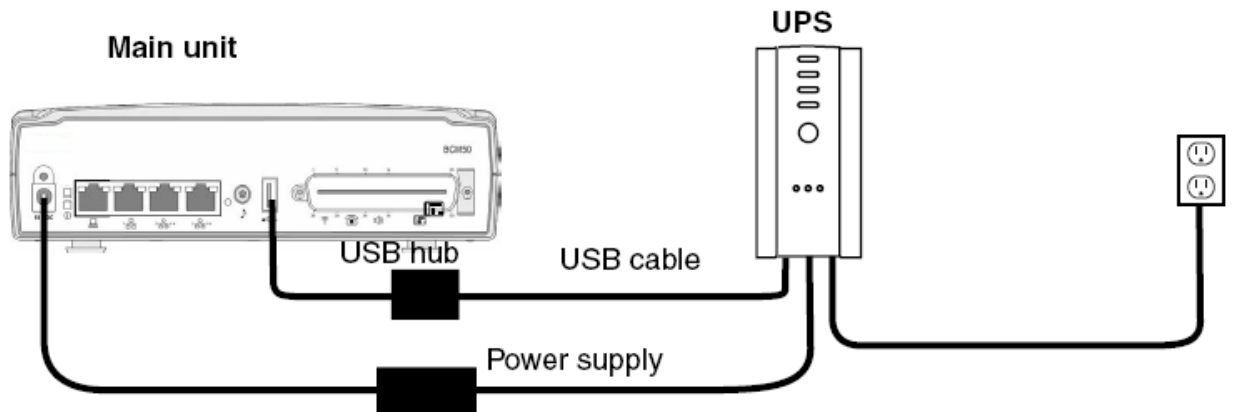

## Power Up Procedure

The BCM50 takes approximately four to five minutes to boot up. There is no on/off switch on the system.

1. Plug the power supply cord into the BCM50 unit, with the power supply cable plugged into the wall outlet.
2. The BCM will start the boot up process.
3. On BCM50 boot-up the status lights will display various states

## LED States

This section describes the Power and Status LED indication.

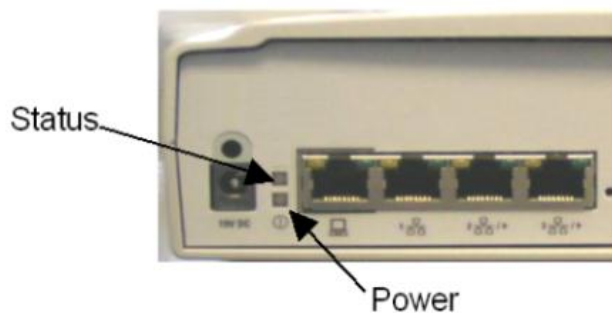

Top View

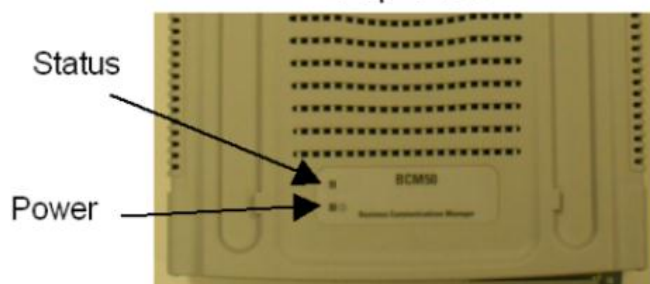

Power	Status	Description
<b>LED status during Start up sequence</b>		
Solid yellow	Solid yellow	Power Applied to System
Solid yellow	Off	Power on self test (POST).
Solid yellow	Solid yellow	System initializing.
Solid green	Solid yellow	Kernel initialization or Safe OS.
Solid green	Flashing green	Services initializing.
Solid green	Solid green	Normal operation.
Solid green	Solid red	Services initialization failed.
<b>LED states seen during Safe Mode start up sequence</b>		
Solid red	Solid green	System running with factory default settings enabled.
Solid red	Solid red	System running in Software Reset mode
Solid red	Flashing yellow	System running in Configuration Reset mode.
<b>LED states seen during shut down sequence or failure</b>		
Solid green	Flashing yellow	Graceful shutdown in progress
Off	Solid yellow	Graceful shutdown completed
Solid red	Flashing yellow	Overheat detected. Thermal shutdown completed
Solid red	Solid red	Power spike or Rail power fluctuation detected.
Flashing red	Solid red	Rail Power fluctuation. Power Monitor Shutdown completed
Solid yellow	Solid red	Power spike shutdown completed (temperature and Rail power ok).
Off	Off	No power, system is shut down (power cable is disconnected)
<b>Start-up Profile LED states (seen only during initial system install or staging)</b>		
Flashing Yellow	Flashing Yellow	Start-up Profile executing
Solid Green	Solid Green	Start-up Profile successfully applied.
Flashing Yellow	Flashing Red	Start-up Profile failure.

Once the BCM50 has booted up and the BCM power and status lights are solid green, the system start up process can then be commenced. Please refer to the ***BCM50 System Start Up Guide*** for further details.

## Additional Information

The following sections contain procedures that may not be necessary in all installations.

### Replacing Internal Components

#### *Hard Disk*

Each of the BCM Platforms are fitted with a 40 GB Maxtor SATA hard disk. SATA: Serial ATA – A newer type of hard disk controller allowing faster data transfer than EIDE controllers. The SATA cable from motherboard to hard drive is significantly narrower than the IDE cables

#### *Required Equipment*

Before commencing hard disk maintenance functions, you will require the following equipment:

- Anti-static wrist-strap.
- Phillips #2 screwdriver.

You should also prepare the BCM for the maintenance procedure to take place.

1. Check for a recent backup of the BCM50 programming. If there is no recent backup, use Element Manager to back up all of the system data.
2. Use Element Manager to shut down the BCM50 system.
3. Shut down the BCM50.
4. Disconnect all cables.

5. Remove the 3 screws labelled "A" on the base of the unit.

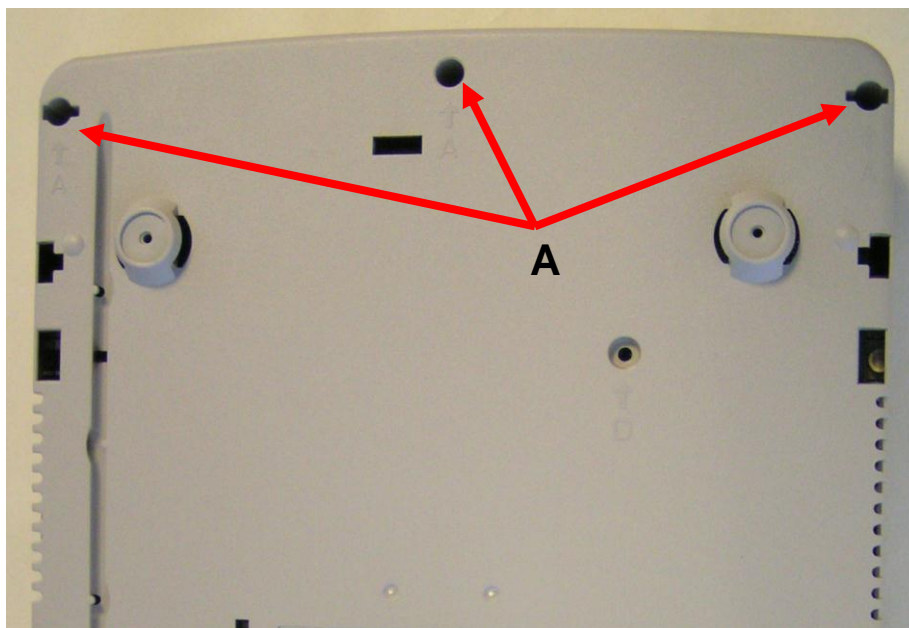

6. Position the main unit flat work area, top facing upwards.
7. Slide off the top of the main unit.

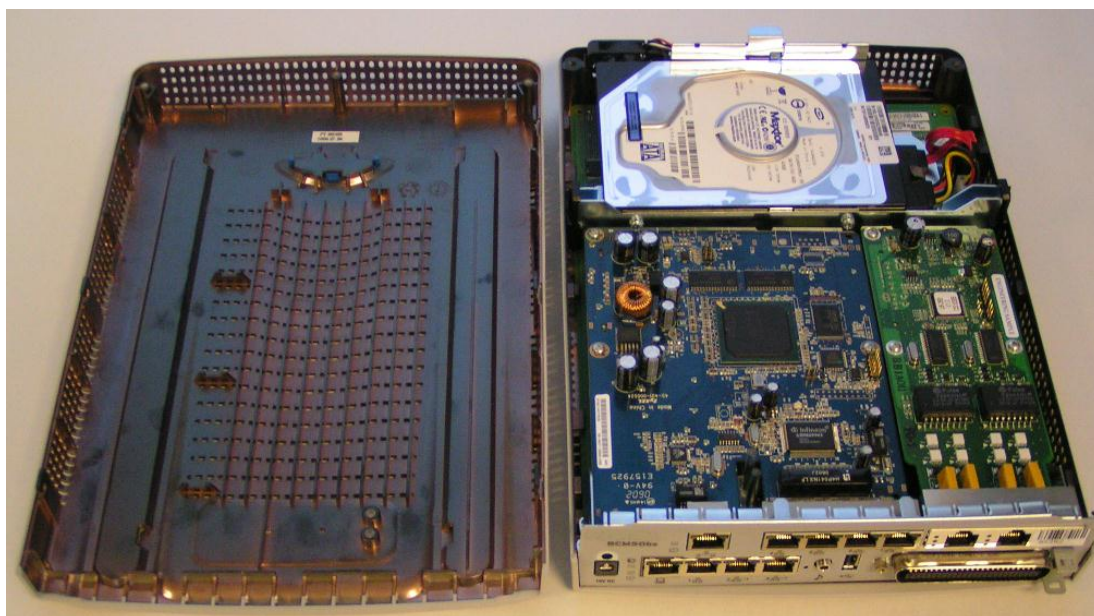



8. Gently disconnect the power cable, the SATA hard drive cable, and the fan connector cable.

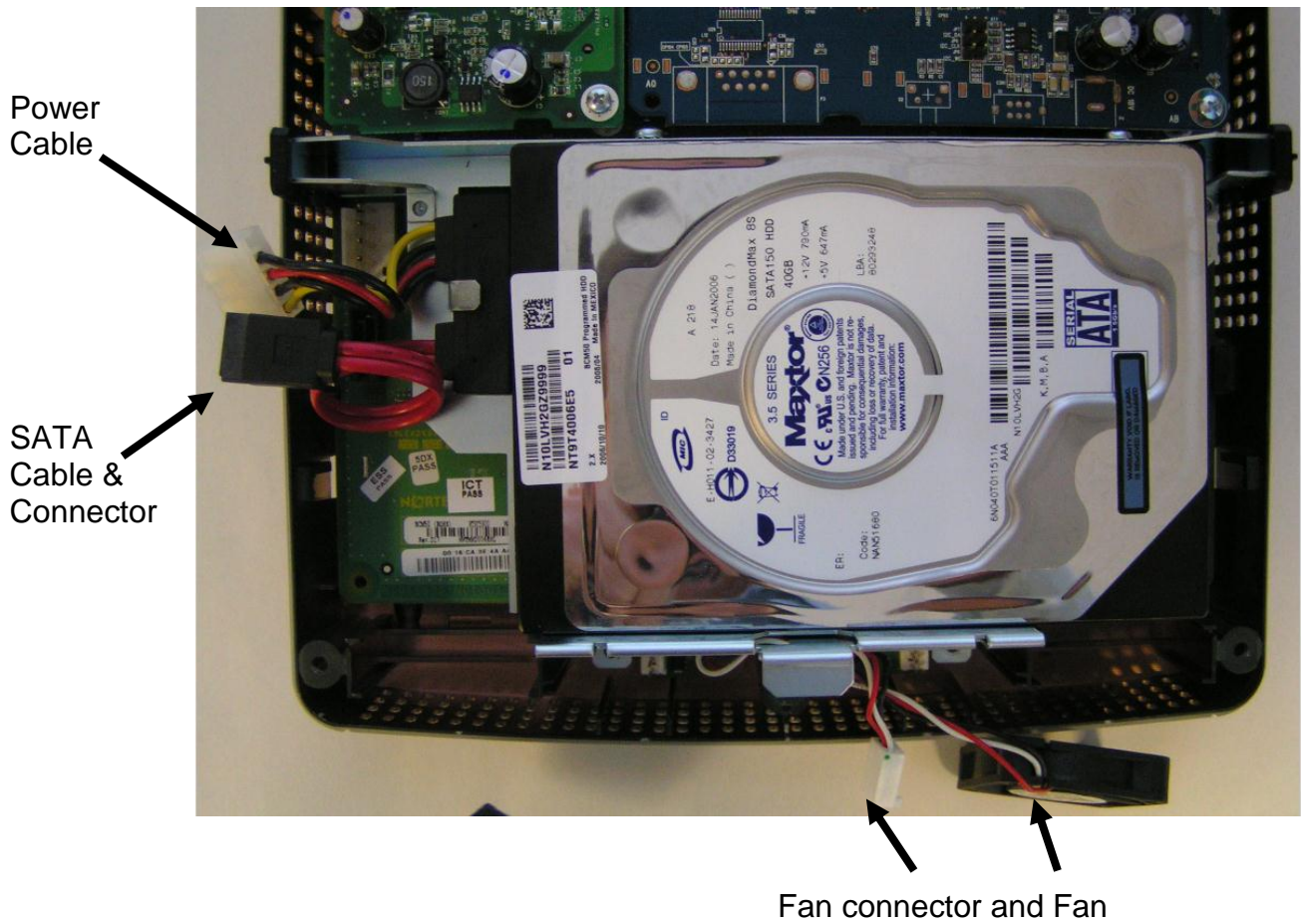

9. Remove the two screws that hold the hard disk bracket to the chassis.

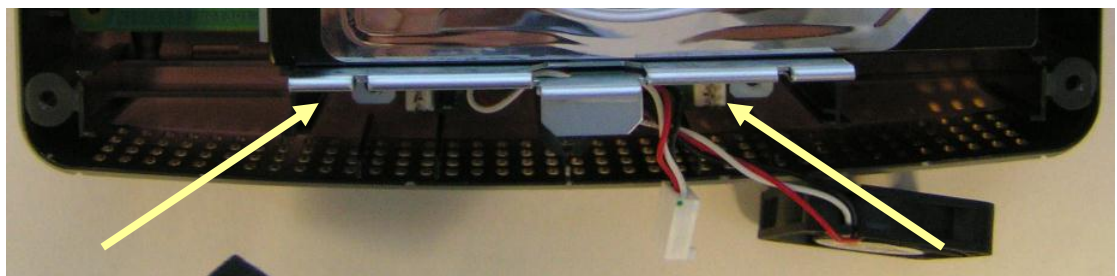



- There are two connection clips (one either side of the chassis) that hold the hard drive bracket securely in position. These need to be gently prized inwards away from the outer chassis to allow the bracket to be lifted out.

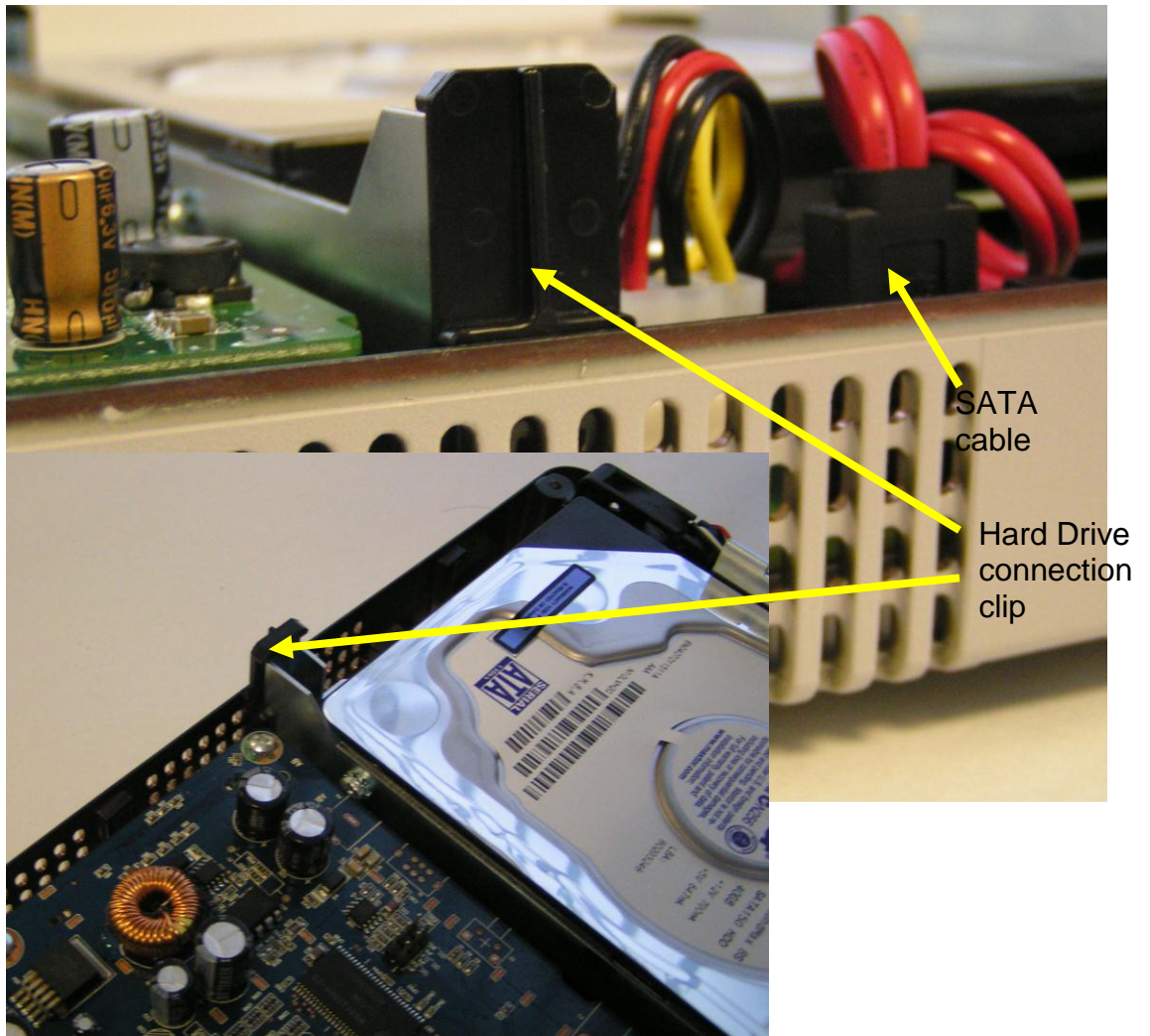

11. Lift the hard disk and hard disk bracket out of the main unit and place them on a flat, clean, static-free surface.

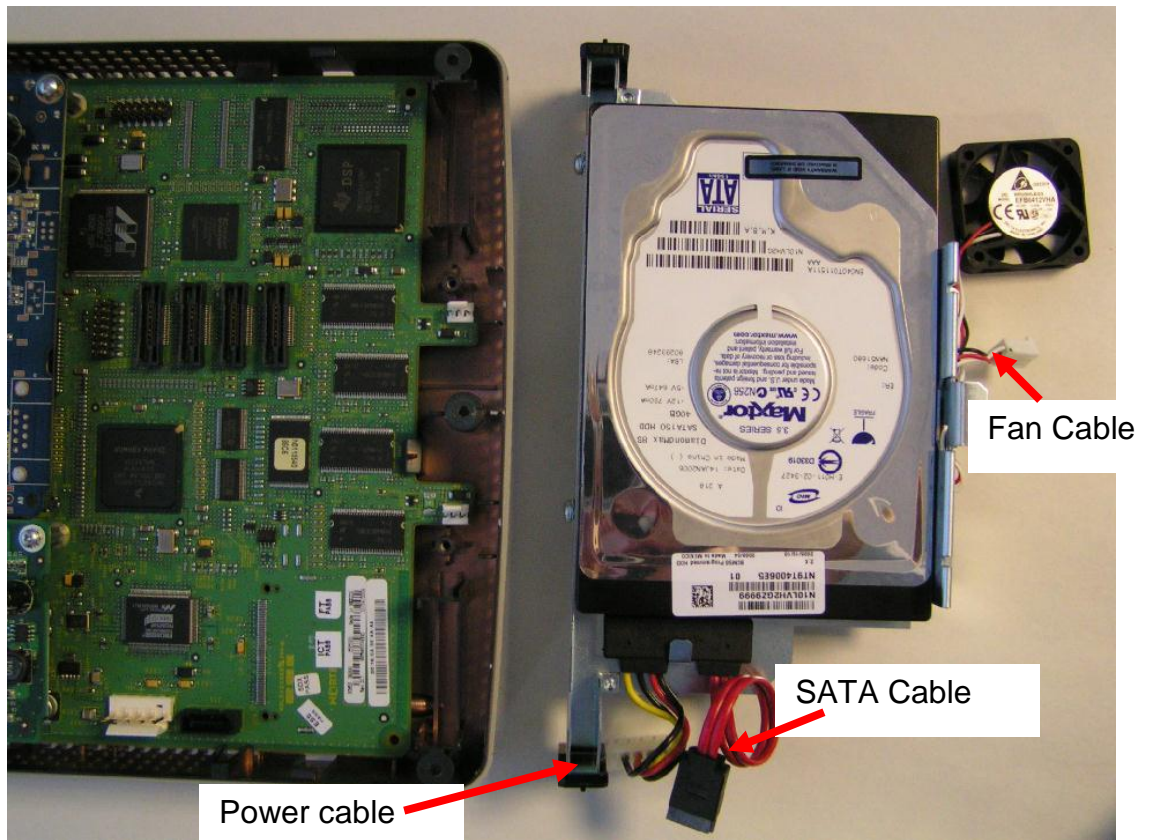

12. Remove the 4 hard drive screws from the hard drive bracket. Remove the hard drive.

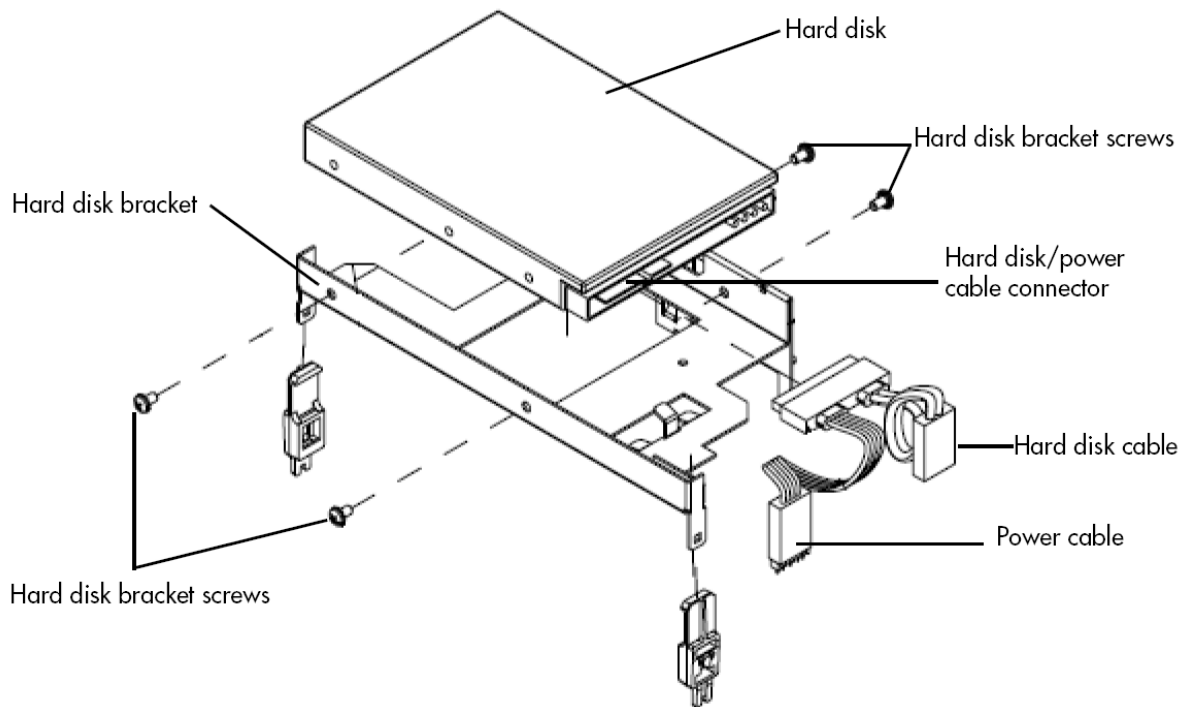

13. Remove the hard disk and power cable from the connector.
14. Lift the hard disk off the hard disk bracket and set it on a flat, clean, static-free surface.
15. Place the new hard disk in the hard disk bracket. Use the four hard disk bracket screws to secure the hard disk to the bracket.
16. Set the hard disk and bracket in the main unit. Make sure that the hard disk cable and power cable are routed properly. Route the power cable under the bracket and loop the hard disk cable.
17. Press down lightly on the top of the hard disk to ensure that the hard disk bracket is seated properly.



18. Fasten the hard disk assembly to the main unit with two screws. Use only the supplied screws, since other screws can damage the unit.



19. If you have just installed a Multi-Image hard drive, please now proceed with the **Preparing the Multi-Image Hard Drive** section.

20. Perform a restore or manual reprogram of the system.

### ***Preparing the Multi-Image Hard Drive***

The Multi-Image Hard Drive field Replaceable Unit contains multiple BCM software images. This allows for a common hard drive FRU to be installed in either a BCM50 or BCM450 chassis, and offers a range of software releases to be applied to the BCM having the hard drive replaced.

Once installed, the preparation process involves powering up the BCM, connecting to the BCM via a SSH client such as PuTTY to access the command menu, and selecting the correct software version for the BCM. On process completion, all non-required images will have been erased, and the BCM will boot up ready for a restore of a previous backup, or manual re-programming via the System Start Up process (refer to the **System Start Up Guide**).

**Note:** Perform the preparation process from a PC connected to the OAM port of the BCM.

Use the following procedure to select the required software release of the Multi-Image hard drive.

1. Once the hard drive is correctly installed, as described in the **Hard disk** section of this guide, connect a PC to the OAM port of the BCM and power up the BCM. If you experience problems in connecting to the BCM when configured to obtain an IP address automatically via DHCP, configure your PC with the following IP settings:
  - IP Address = 10.10.11.2
  - Subnet Mask = 255.255.255.252
2. When the BCM is ready to accept a SSH client connection, the Power LED will be full green, and the Status LED will be blinking orange. Open up a SSH client such as PuTTY, and connect to the default OAM port address 10.10.11.1

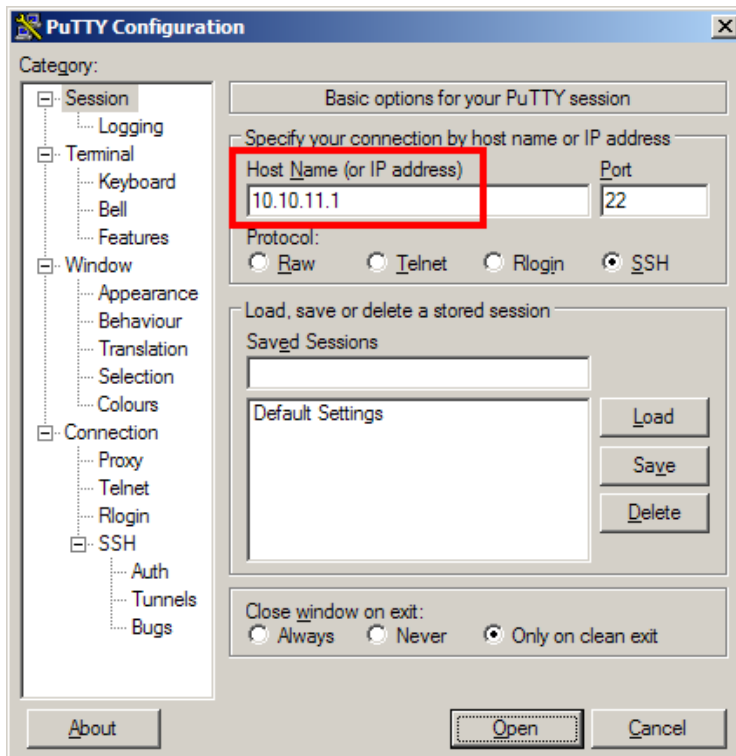

3. Login to the BCM using the default details:
  - User = **nnadmin**
  - Password = **PlsChgMe!**

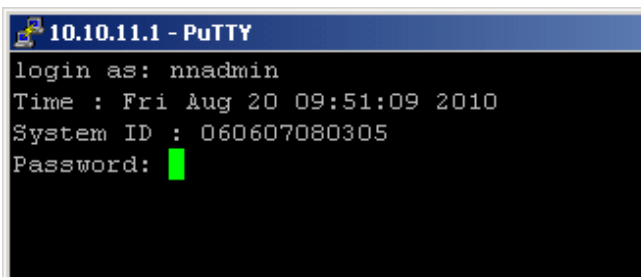

4. The Quick Configuration menu will display. Select **1 -> Install and Activate a BCM SW Release**.

```

10.10.11.1 - PuTTY
-----
..... BUSINESS COMMUNICATIONS MANAGER .....
-----

                        QUICK CONFIGURATION
=====

(0)---> Exit
(1)---> Install and Activate a BCM SW Release
(2)---> Advanced Menu
(3)---> Display status of BCM SW Release installation
(4)---> Reboot
(5)---> Shutdown
(6)---> Help

=====

Make Selection [ 0 1 2 3 4 5 6 ] : █
    
```

5. Detection of the BCM hardware type - i.e. BCM50 or BCM450 (BCM 200/400 5.0 or later systems will be detected as BCM450) – will begin.

```

10.10.11.1 - PuTTY
Install is currently not running
Detecting Hardware, Please wait!
█
    
```

- When the hardware type has been detected, you will be presented with the option of applicable software releases to apply to the hard drive. Enter the required software release.

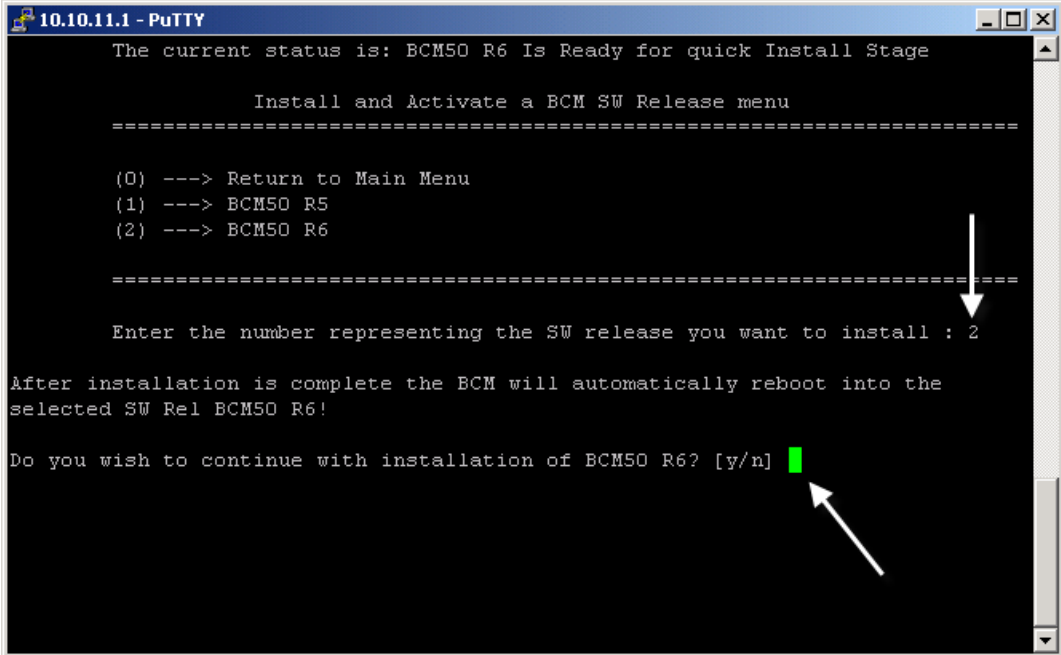

```
10.10.11.1 - PuTTY
The current status is: BCM50 R6 Is Ready for quick Install Stage

Install and Activate a BCM SW Release menu
=====
(0) ---> Return to Main Menu
(1) ---> BCM50 R5
(2) ---> BCM50 R6
=====
Enter the number representing the SW release you want to install : 2

After installation is complete the BCM will automatically reboot into the
selected SW Rel BCM50 R6!

Do you wish to continue with installation of BCM50 R6? [y/n] █
```

- If you have made an incorrect selection, enter **n** at the **Do you wish to continue...** prompt (this will return you to the main menu). Otherwise, enter **y** to confirm and continue.

**Note:** If the wrong software release is selected and confirmed, a new replacement hard drive will be required as the following process is irreversible.

- The selected software release will be applied to the hard drive, and could take up to 25 mins to complete. The SSH client will be disconnected from the BCM.

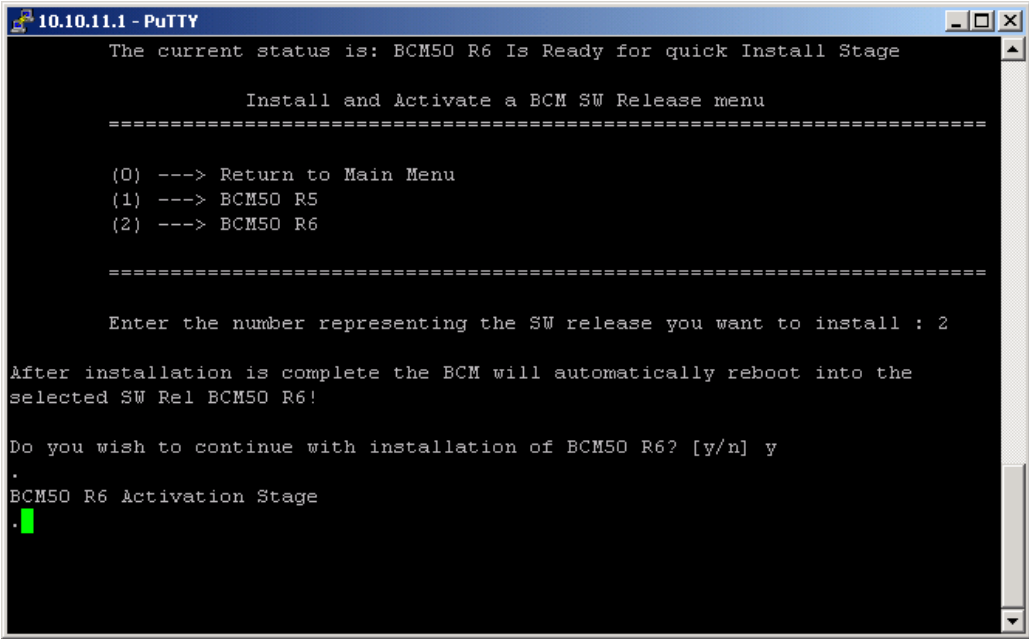

```
10.10.11.1 - PuTTY
The current status is: BCM50 R6 Is Ready for quick Install Stage

      Install and Activate a BCM SW Release menu
=====

(0) ---> Return to Main Menu
(1) ---> BCM50 R5
(2) ---> BCM50 R6

=====

Enter the number representing the SW release you want to install : 2

After installation is complete the BCM will automatically reboot into the
selected SW Rel BCM50 R6!

Do you wish to continue with installation of BCM50 R6? [y/n] y
.
BCM50 R6 Activation Stage
.
```

- Once the process is complete, the BCM will boot up into a normal working state (both the Power and Status LED's should be green). Either perform a restore or manually reprogram the BCM via the System Start Up process (refer to the relevant **System Start Up Guide**).

## Replacing the Fan

The cooling fan circulates air through the chassis or the BCM server to prevent the components from overheating. The BCM50/b, and BCM50e/be have a single cooling fan. The BCM50 Expansion Unit has two cooling fans.

Before commencing Fan maintenance functions, you will require the following equipment:

- Anti-static wrist-strap.
- Phillips #2 screwdriver.

You should also prepare the BCM for the maintenance procedure to take place.

1. Check for a recent backup of the BCM50 programming. If there is no recent backup, use Element Manager to back up of all the system data.
2. Use Element Manager to shut down the BCM50 system.
3. Shut down the BCM50.



4. Disconnect all cables.
5. Follow the procedure for replacing the hard drive.
6. Stop at disconnecting the SATA and power cables.
7. Disconnect fan power cable.

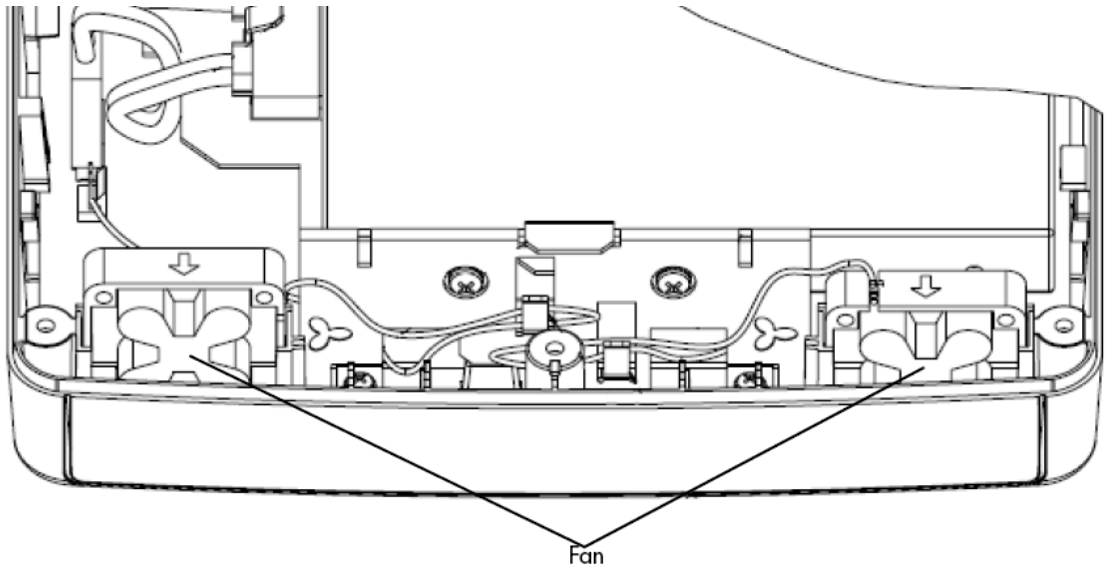

8. Lift the fan out.
9. No screws to remove.
10. Insert new fan in the fan slot.
11. Ensure the label faces the back of the unit.
12. Insert fan power cable.
13. Replace the hard drive/bracket into original location.
14. Attach case and insert case screws.
15. Insert cables and power up.

## ***Replacing the BCM 50(b)e Router Card***

The BCM50(b)e has a router card that uses an ethernet interface to connect to a WAN edge device (for example, an external ADSL modem or cable modem).

Before commencing Router Card maintenance functions, you will require the following equipment:

- Anti-static wrist-strap.
- Phillips #2 screwdriver.

You should also prepare the BCM for the maintenance procedure to take place.

1. Check for a recent backup of the BCM50 programming. If there is no recent backup, use Element Manager to back up of all the system data.
2. Use Element Manager to shut down the BCM50 system.
3. Disconnect all cables.
4. Remove the 3 screws labelled "A" on the base of the unit.

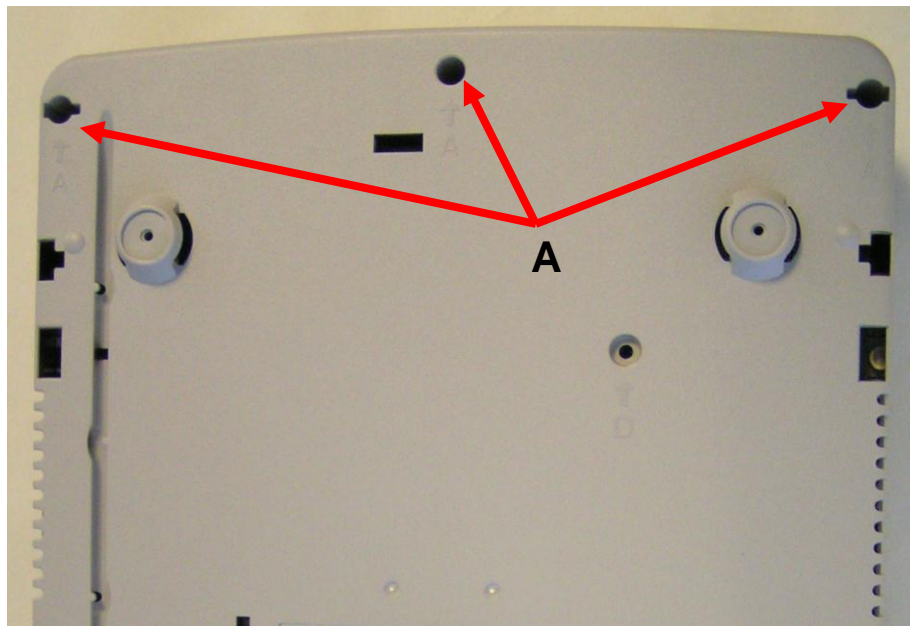

5. Position the main unit flat work area, top facing upwards.

6. Remove the top part of the case.

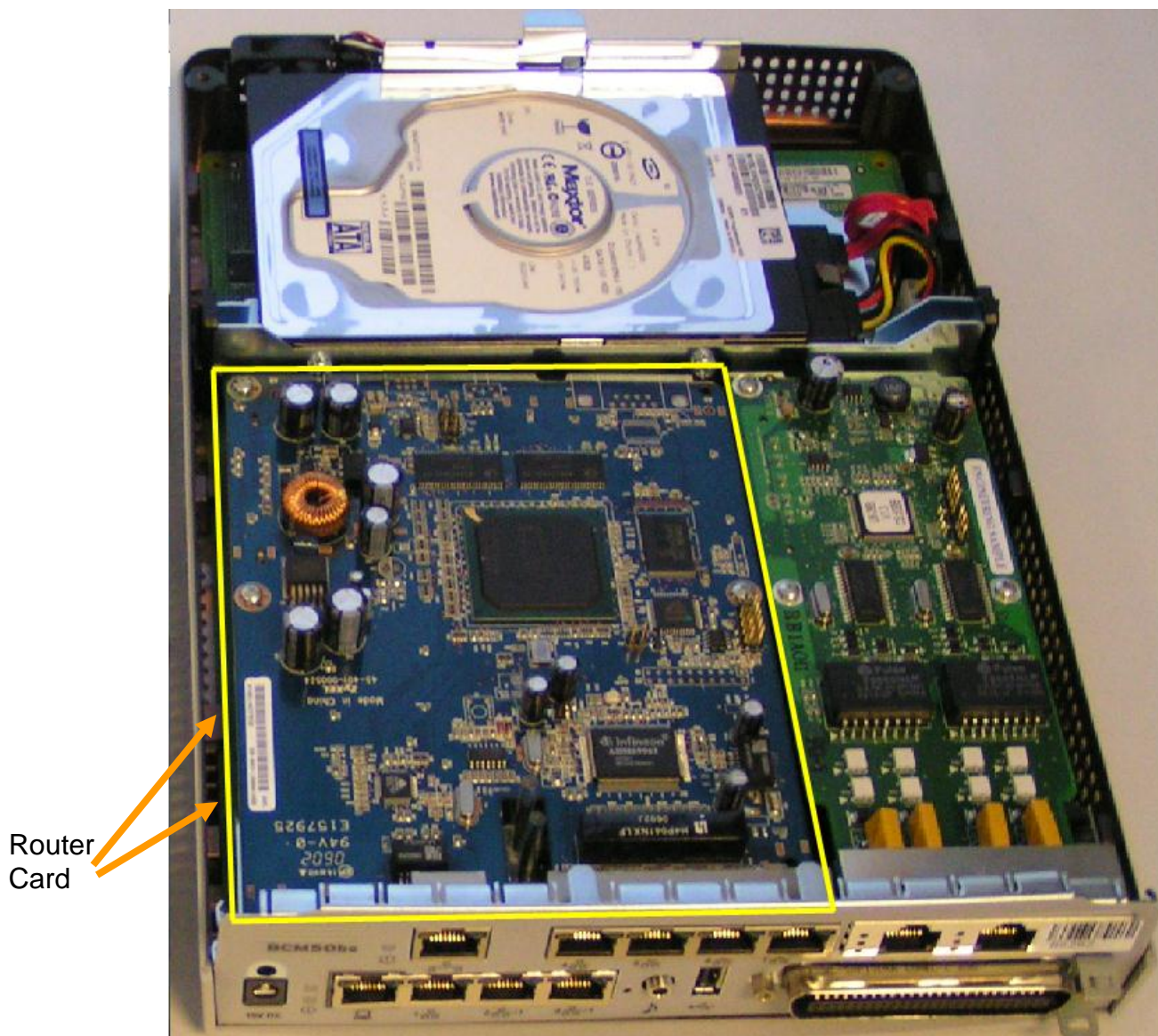



- Remove the 3 screws securing the Router card to the motherboard.

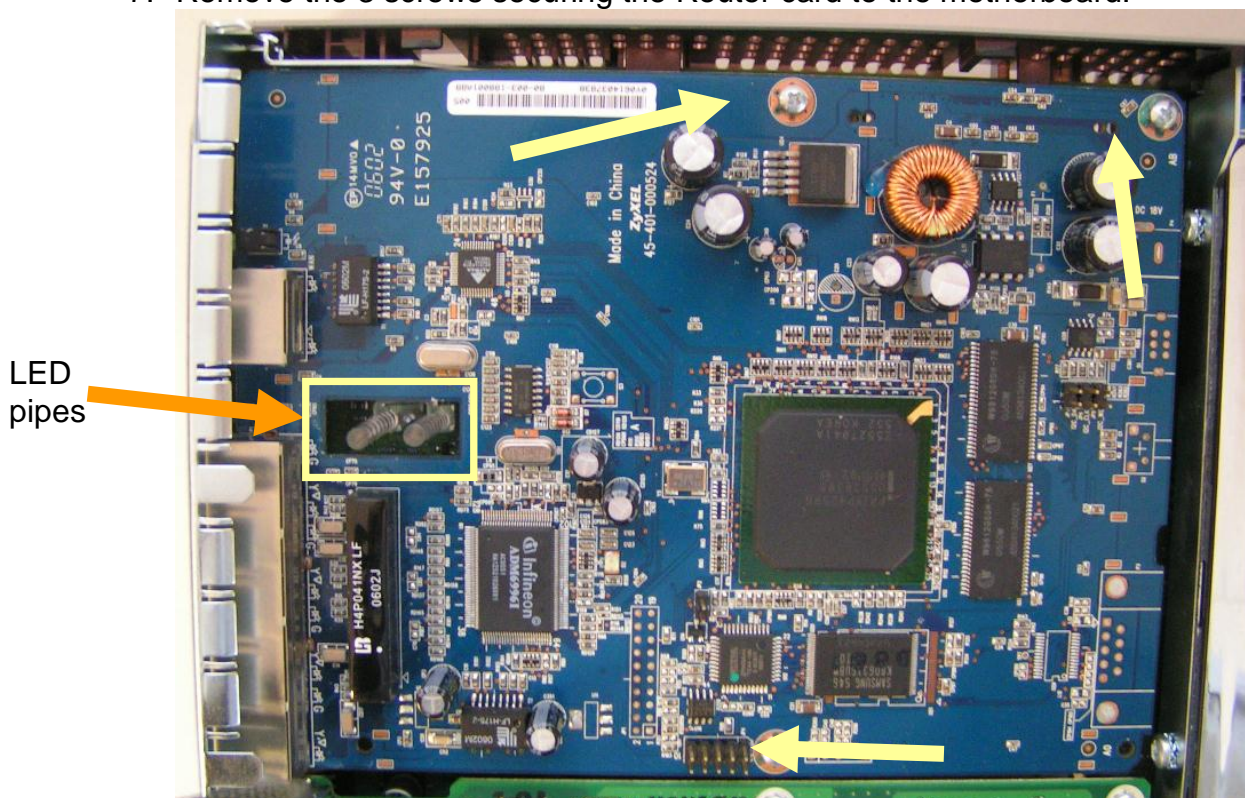

- Holding the card near the back, gently lift until it detaches from the motherboard connector.
- Gently lift the back of the router card to disengage it from the card connector.
- Slide the router card back so the modular connectors clear the bezel.
- Lift the router card over the top of the LED pipes and place it on a flat, clean, static-free surface.
- With the back of the new router card raised enough to clear the LED pipes, align the modular connectors on the router card with the corresponding holes in the bezel.
- Move the router card forward until the front edge of the card touches the bezel.
- Align the card connector on the router card with the connector on the Compact Services Card.
- Gently press down on the back of the router card to seat the router card in the connector on the Compact Service Card.
- Re-attach case and cables and power up the BCM.

## Replacing the Cover of the Main Unit

1. Attach one end of a grounding strap to your wrist and the other end to a grounded metal surface.
2. There are a number of L shaped connectors that will connect into the main chassis of the BCM50.



3. Place the top of the case on top of the main unit case. Make sure the side edges of the case are aligned and the front of the top is back about 1 cm (3/8 in.).

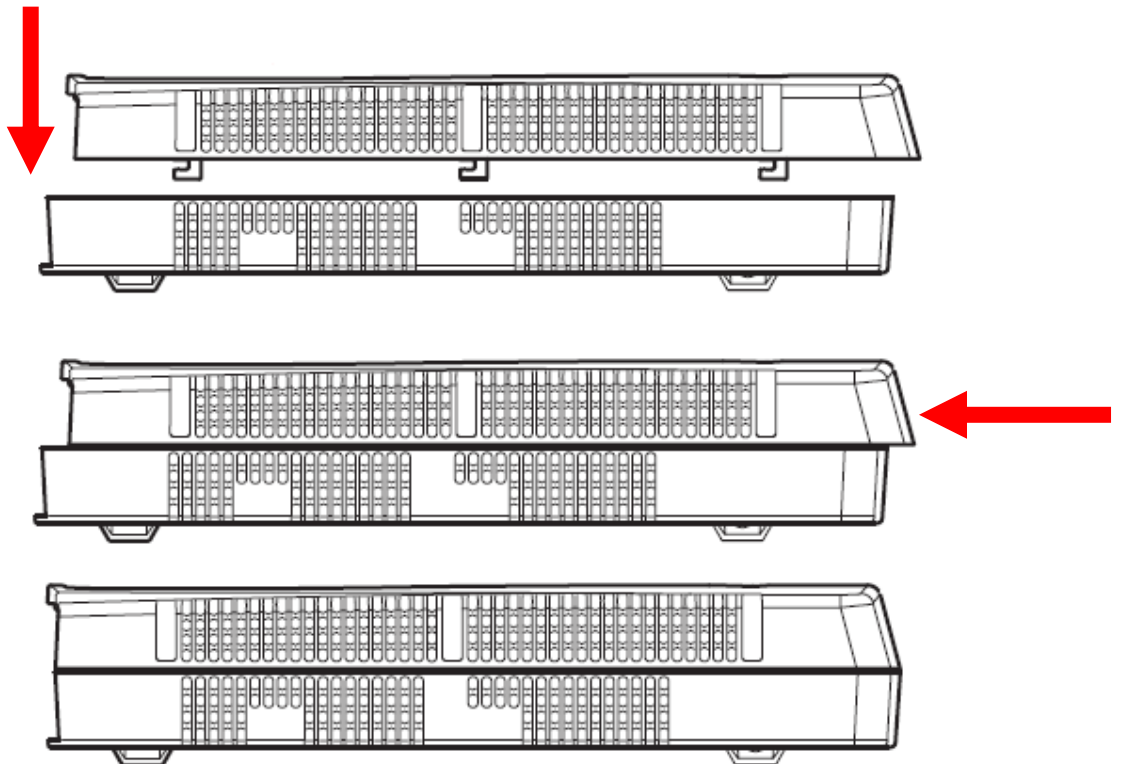

4. Slide the top of the case forward until it clicks in place.
5. Turn the main unit over so you can access the screws holes on the bottom of the unit.
6. Insert the three case screws in the back of the unit and tighten them.

## Installing the Wiring Field Card (WFC)

You install the optional wiring field card (WFC) in the cable management tray of the BCM50 wall mount bracket.

To install the WFC:

1. Clear the WFC installation area of all cables.
2. Place the WFC in the installation area with the 50-pin header/cable connector at the top.
3. Slide the WFC down until it is at the bottom of the installation area and held in place by the three clips.

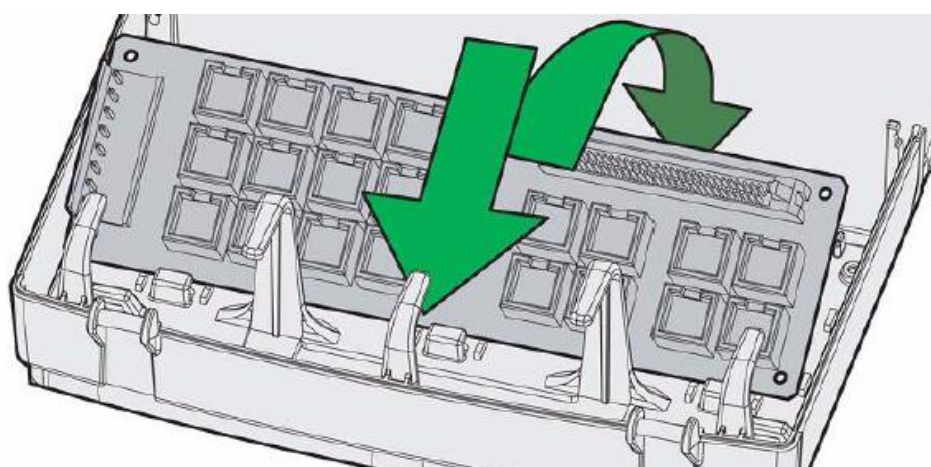

4. Press the WFC firmly at the top left corner, center, and right tabs.
5. The WFC snaps into place.
6. Optional – Install the three screws to secure the WFC in place.

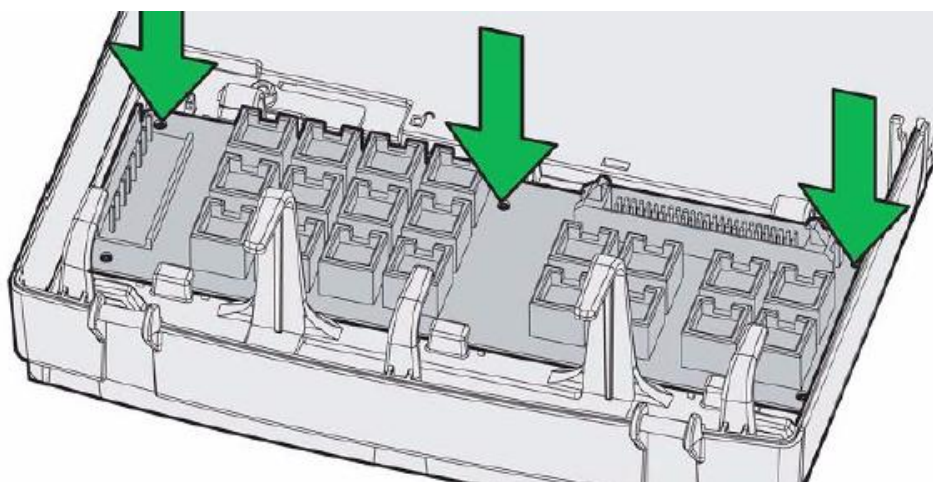

### ***Connecting Cables to the Wiring Field Card***

If you are using the optional wiring field card (WFC), use this procedure to connect the cables to WFC.

1. Plug the RJ21-end of the cable assembly into the telephony connector.
2. Plug the other end of the cable assembly into the WFC header.
3. The cable locks in place.
4. Remove the terminal block from the WFC.
5. Slide a small flat screwdriver into the rectangular opening at the back of the terminal block.
6. Pry the terminal block such that the top rotates forward and the block comes free.
7. You make the connections to the terminal block while it is removed from the header.
8. Use a small slotted screwdriver to unscrew the wire hole screws on top of the terminal block.
9. Insert the bare wire ends ( $\frac{1}{4}$ " or 6mm) in the appropriate holes on the sides of the terminal block.
10. Tighten the screws to hold the wires in place.
11. Re-install the terminal block on the header of the WFC.
12. Connect the remaining wires (digital telephones, analog telephones, and analog trunks) to the WFC.
13. The 8-pin modular jacks on the WFC accept RJ45 or RJ11 modular plugs.
14. Connect cables to the BCM50 as required.

## ***Connecting Cables to the Patch Panel***

If you are using the optional patch panel, use this procedure to connect the cables to WFC:

1. Plug the RJ21-end of the cable assembly into the telephony connector.
2. Plug the other end of the cable assembly into the patch panel header.
3. The cable locks in place.
4. Connect the wires (digital telephones, analog telephones, and analog trunks) to the patch panel.
5. Connect cables to the BCM50 as required.

## **Reset Button**

The BCM Reset button performs two functions:

1. Initialises a graceful reboot
2. Performs an immediate reboot

To access the reset button, you will need a thin, non-metallic object.

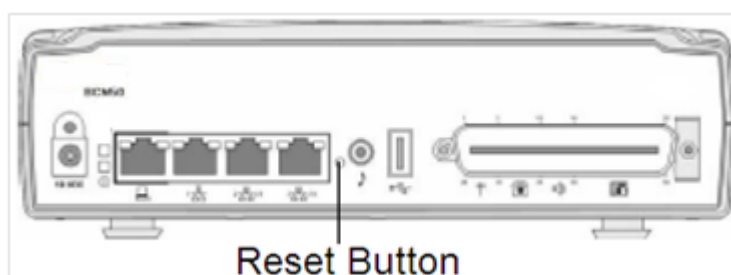

## ***Graceful Reboot***

Initialising a graceful reboot is the preferred hardware reboot option. The reboot process can be started safely, without loss of data.

1. Using the thin, non-metallic object, press and hold the reset button for less than 5 seconds.
2. The reboot process will begin when the system is ready.



## ***Immediate Reboot***

Only use this process if the BCM is not responding to the usual reboot commands, e.g. through Element Manager. Data loss may occur.

1. Using the thin, non-metallic object, press and hold the reset button for more than 5 seconds.
2. The reboot process will begin immediately.

## **BCM Command Line Interface**

The BCM Command Line Interface (CLI) provides configuration information and reset utilities and is dependent on which state the BCM is in:

- Configuration CLI
- Maintenance CLI

### ***Configuration CLI***

The Configuration CLI can be accessed during normal operation and provides the following options:

- 0 - Exit.** The system exits the CLI to the login prompt.
- 1 - Reboot.** The system reboots to the Main OS.
- 2 - Shutdown.** The system shuts down. You need physical access to the BCM450 hardware to restart the system.
- 3 - Safe OS.** The system reboots to the Safe OS and waits 1 minute for you to login. When you login within 1 minute, the Maintenance CLI displays. If you do not login within 1 minute, the system changes to the Main OS.
- 4 - Configuration Reset.** A Level 1 reset occurs. The system resets all configuration data to the factory defaults.
- 5 - Software Reset.** A Level 2 reset occurs. The system resets all configuration data and software to the factory defaults.
- 6 - IP Configuration.** You can configure the following basic IP settings:
  - 0 - Return to Previous Menu. The system returns to the main menu.
  - 1 - Hostname. The hostname of the system.
  - 2 - IP Address. The IP address of the system.
  - 3 - Subnet Mask. The subnet mask for the IP address.
  - 4 - Default Gateway. The default gateway for the system.
  - 5 - DHCP Client Mode. Enable or disable the DHCP client.
  - 6 - Commit Changes. Save changes to the IP settings.
  - 7 - Reload Settings. Reload the existing IP settings.

## ***Maintenance CLI***

The Maintenance CLI displays when the system is in the Safe OS mode. The Safe OS is a diagnostics mode that can be used if the Main OS is experiencing problems. No applications or telephony services are running when the BCM is in Safe OS mode.

**Note:** It is recommended that you access the Maintenance CLI only under the advice of support personnel.

The Maintenance CLI can be accessed from option 3 of the Configuration CLI (select option 3 and attempt to access the CLI within 1 minute). The following options can then be used:

- 0 - Exit.** The system exits to the Safe OS login prompt.
- 1 - Reboot into Main OS.** The system reboots to the Main OS.
- 2 - Shutdown.** The system shuts down. You need physical access to the BCM450 hardware to restart the system.
- 3 - Reboot into Safe OS.** The system reboots to the Safe OS and waits 1 minute for you to login. If you do not login within 1 minute, the system changes to the Main OS.
- 4 - Transition to Main OS.** The system changes from the Safe OS to the Main OS without restarting.
- 5 - Configuration Reset.** A Level 1 reset occurs. The system resets all configuration data to the factory defaults.
- 6 - Software Reset.** A Level 2 reset occurs. The system resets all configuration data and software to the factory defaults.

## ***Accessing the Command Line Interface Using PuTTY***

PuTTY is a software tool that can be used to access the BCM CLI, and can be downloaded from the Administrator Applications web page.

Use the following procedure to install PuTTY and connect to the BCM CLI.

1. Open Internet Explorer. In the address field type (replacing the relevant part with your BCM IP address): **http://<bcm ip address>/**

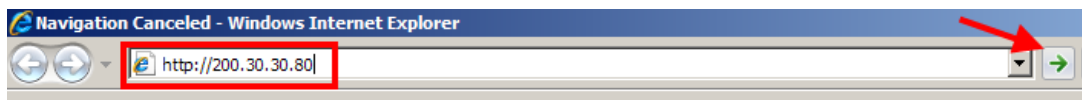

2. Click on **Go**, or press Return on your keyboard.

**Note:** You can also use the Web Page button in Element Manager to launch a web browser session. The BCM you wish to access must be selected in the Element Navigation Panel to do this.

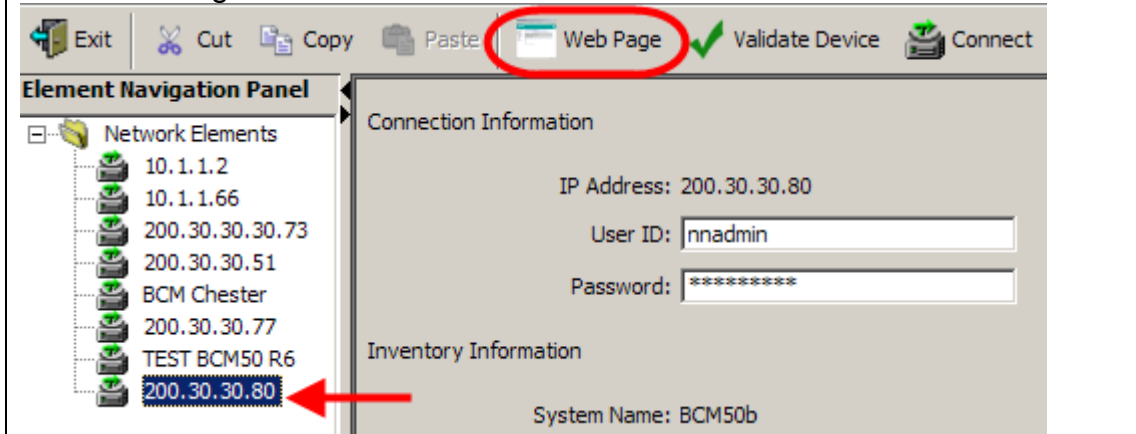

3. If you are presented with the Certificate Error window, click on **Continue to this website (not recommended)**.

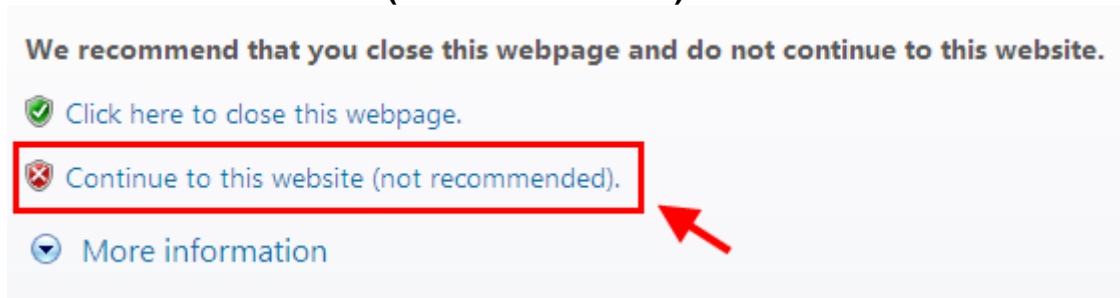

4. Accept any further security messages that you may get presented with.

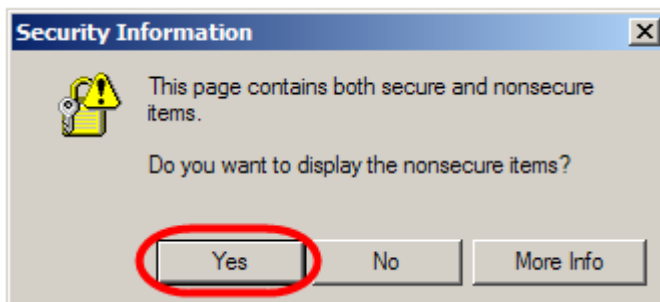

- You will now see the login screen, enter your BCM User name and Password. By default these are set to User ID: nnadmin Password: PlsChgMe! Click on **OK**.

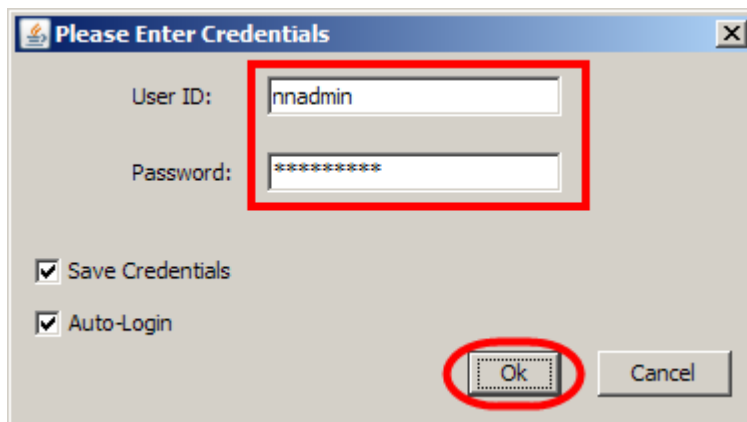

- In the Welcome to BCM window, ensure the **Main** tab has been selected, and the **BCM** button clicked.

**Welcome**

to

**BCM**

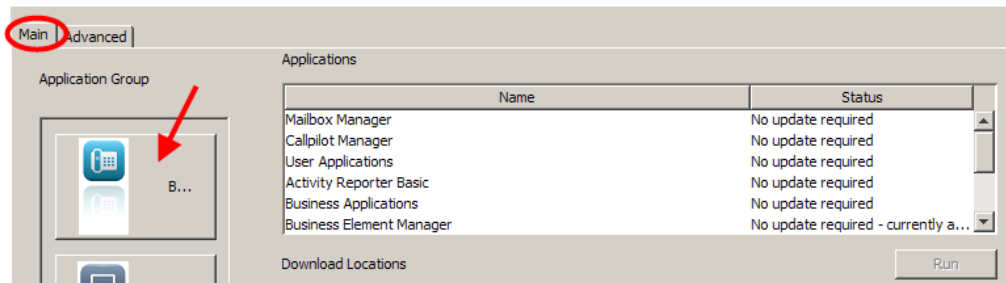

- From the **Applications** list, select **Other Administrator Applications** and click **Run**.

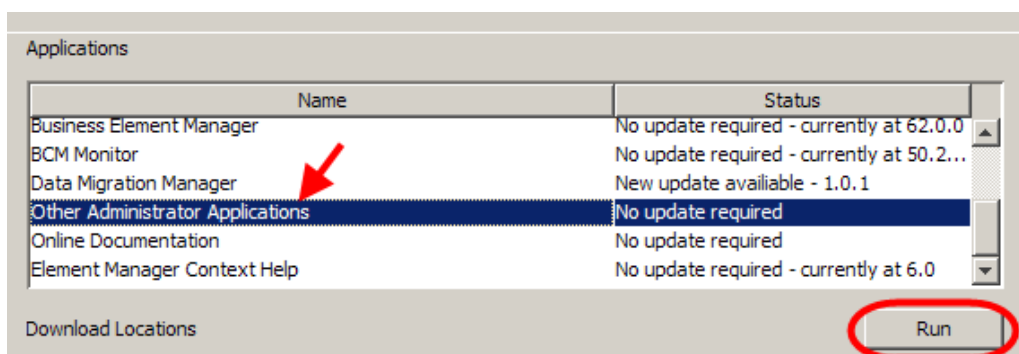

8. Again, accept any security messages that appear, and if prompted enter any login details.
9. The Administrator Applications screen will be displayed.
10. In the **Administrator Applications** window, click on the **SSH Client (PuTTY)** link, followed by **Download PuTTY SSH Client**.

## Administrator Applications



## SSH Client



The PuTTY SSH Client is provided for use should there be a need to perform advanced tasks to resolve a BCM5.0 issue.

Contact Support for authorization to use this client.

11. Click on the **Run** button to install the application.

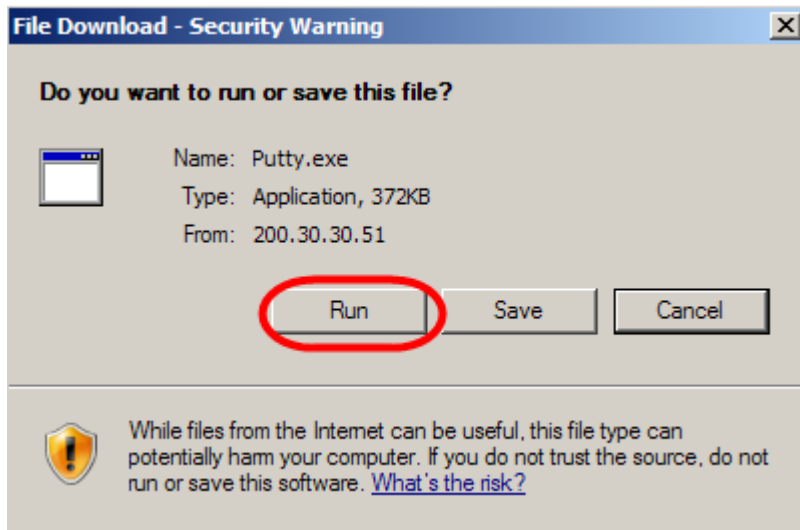

12. Click on **Run** again.



13. When installed, the PuTTY program will automatically launch. Enter the IP Address of the BCM in the **Host Name (or IP Address)** field, and click **Open**.

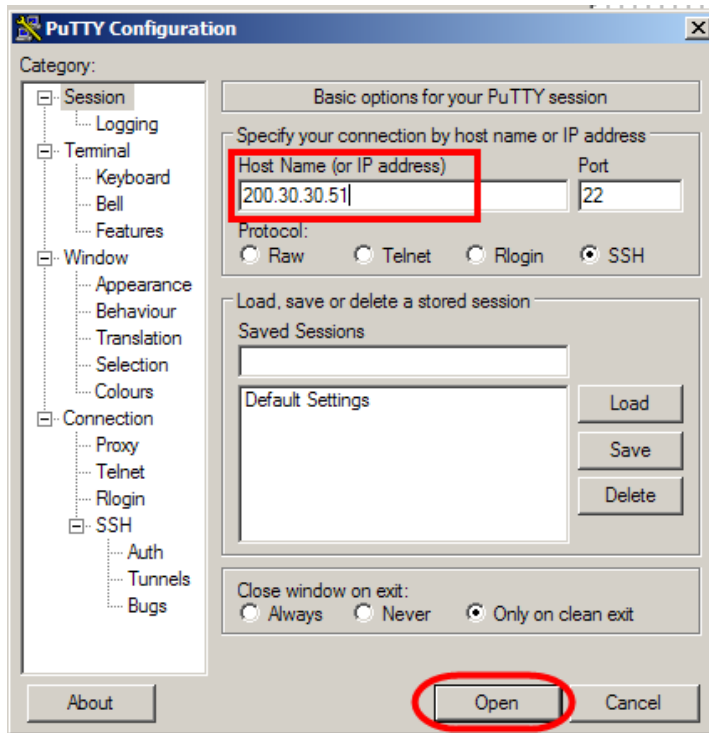

14. You must now login to the BCM with Administrator credentials. Type in the user name after **login as:** and press the **Enter** key on your keyboard. Then type in the password, again followed by **Enter**.



```
200.30.30.51 - PuTTY
login as: nnadmin
Wed Oct 14 10:37:14 2009

001765FA5A95
Password: █
```

15. You will then be presented with the CLI. Make your selections as described in the **Configuration CLI** or **Maintenance CLI** sections of this guide.

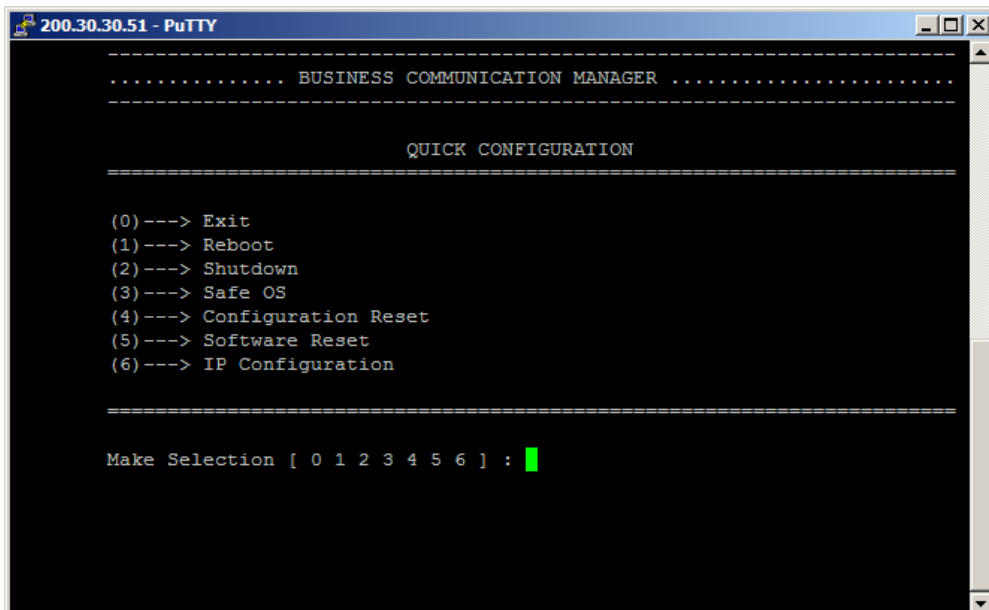

```
200.30.30.51 - PuTTY
..... BUSINESS COMMUNICATION MANAGER .....

QUICK CONFIGURATION

(0)---> Exit
(1)---> Reboot
(2)---> Shutdown
(3)---> Safe OS
(4)---> Configuration Reset
(5)---> Software Reset
(6)---> IP Configuration

Make Selection [ 0 1 2 3 4 5 6 ] : █
```

## Upgrading to BCM RIs 6.0

Any previous version of the BCM50 can be upgraded to BCM RIs 6.0. However, BCM50 RIs 1.0 systems should first be upgraded to BCM RIs 3.0 before performing the 6.0 upgrade. Upgrading directly from BCM RIs 2.0, 3.0 and 5.0 to BCM RIs 6.0 is supported.

In addition to the BCM RIs 6.0 upgrade files, the process will also require the application of the BCM RIs 6.0 Factory Image. This ensures that if a Software Reset is performed (refer to the **BCM Command Line Interface** section of this guide) the BCM will not revert to its previous software level. If upgrading from RIs 1.0 to RIs 3.0 to RIs 6.0, the RIs 3.0 Factory Image should also be applied after the RIs 1.0 to RIs 3.0 upgrade has been performed.

**Note:** When upgrading a BCM50a/ba or BCM50e/be system, the router card is not upgraded using the process described in this section.

**Note:** When the upgrade files have been transferred to the BCM and the files are being applied, the BCM services will be unavailable until after the upgrade has been completed.

**Note:** As with all BCM upgrades, please consult the accompanying Release Notes for any specific instructions.



## BCM50 Upgrade Flow Charts

Please read and follow the below processes to ensure that the correct steps are performed for your particular upgrade.

### *Upgrading from BCM50 RIs 1.0 to RIs. 6.0*

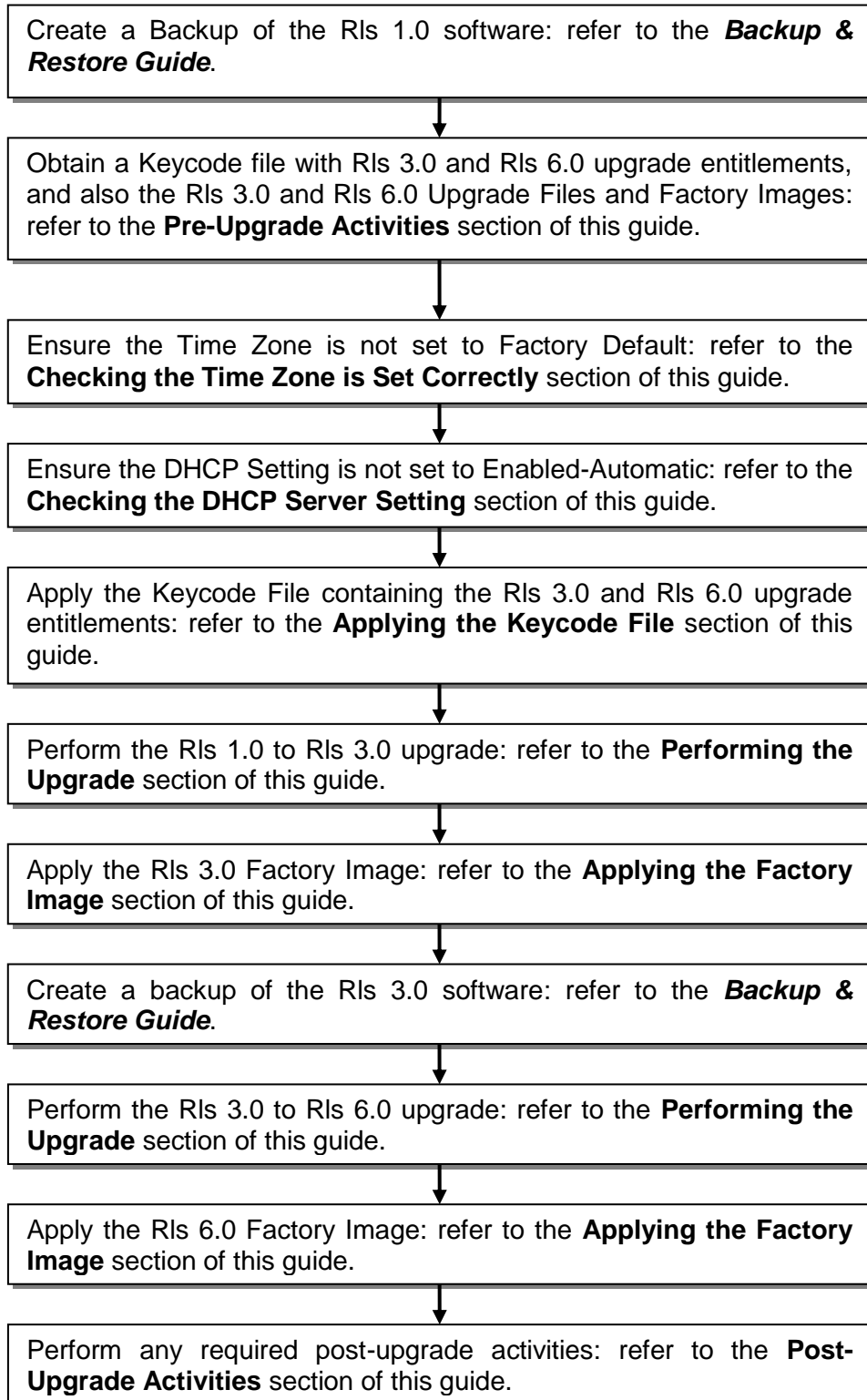

## **Upgrading from BCM50 RIs 2.0 to RIs. 6.0**

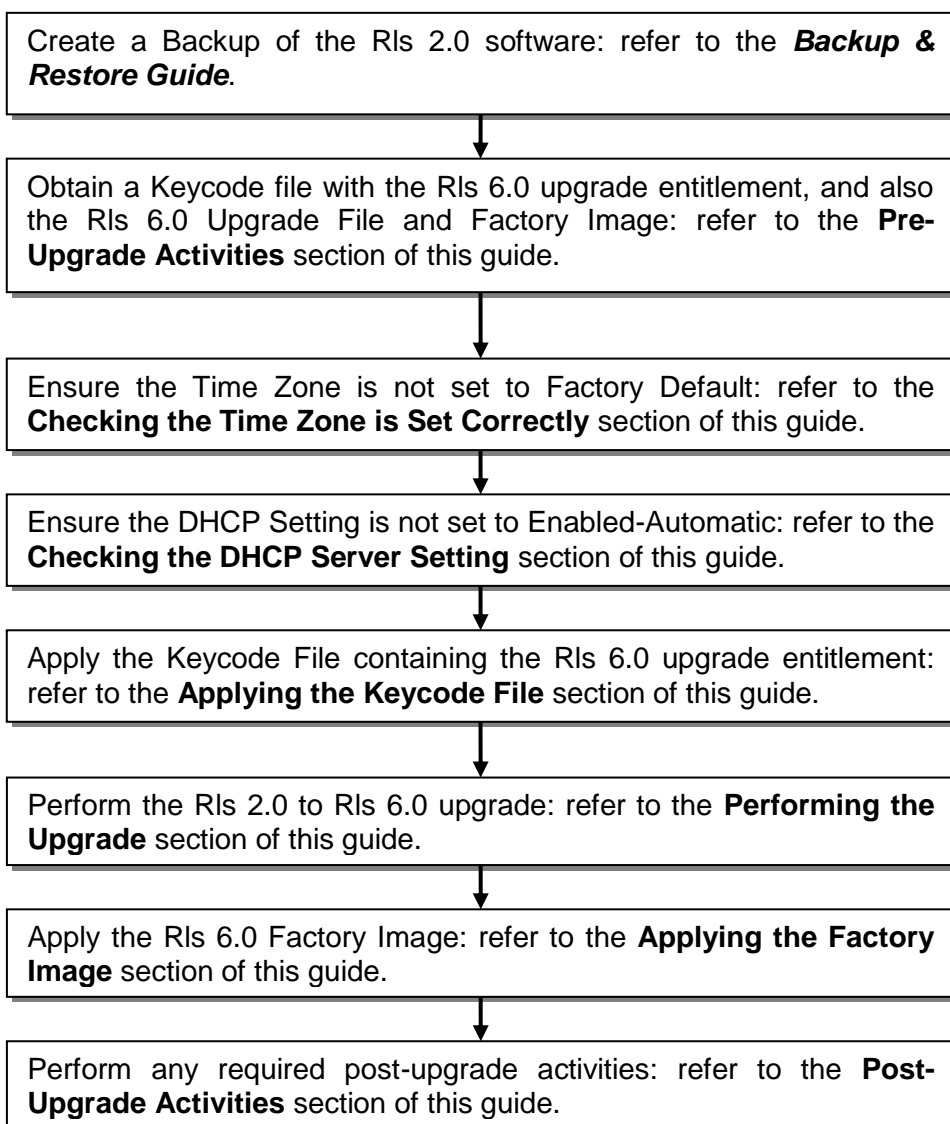

## Upgrading from BCM50 RIs 3.0/5.0 to RIs. 6.0

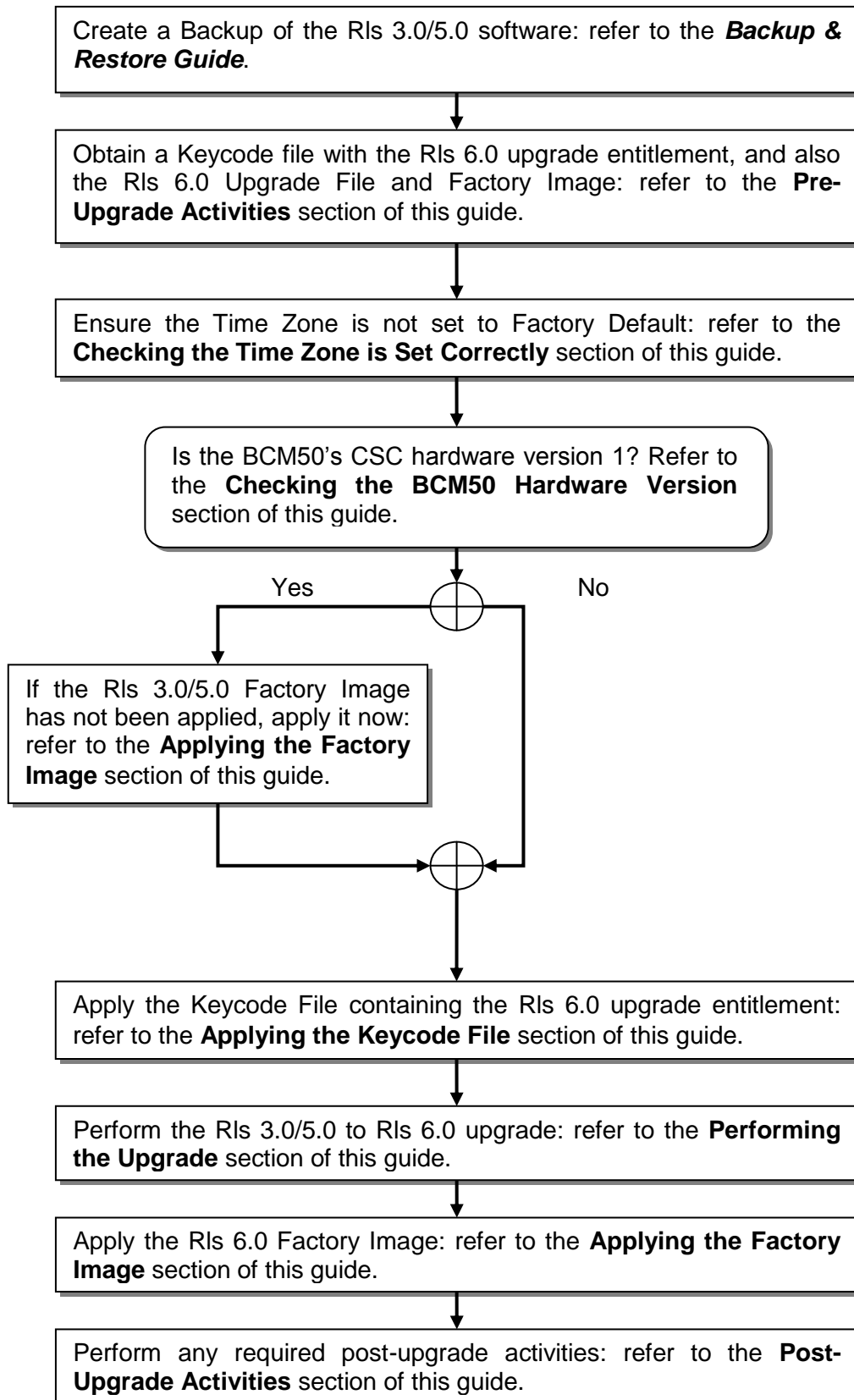

## Pre-Upgrade Activities

Before commencing the upgrade procedure, it is recommended that you perform the following actions:

- Create a backup of your current BCM configuration. If the upgrade process fails, you should be able to retrieve the configuration. Refer to the ***Backup and Restore Guide*** for further information.
- Obtain a keycode file with the upgrade entitlement. This will need to be applied to the BCM prior to performing the upgrade.
- Obtain the Upgrade and Factory Image files. If they are still zipped, extract them to a suitable location from which the BCM can access. A suitable location could be:
  - Your PC/laptop (i.e. the PC/laptop performing the upgrade via Element Manager)
  - A network folder accessible to the BCM
  - A FTP server
  - A http or https server

**Note:** It is not recommended to perform the upgrade via the USB port, as the BCM50 USB port uses USB 1.1, i.e. the USB 1.1 data transfer rate would extend the time of the upgrade process.

### Checking the BCM50 Hardware Version

Early BCM50 models may exhibit problems or disruption during the upgrade process, if the recommended procedures are not followed. If there is a possibility that the BCM you are upgrading has a CSC hardware version 1, check the hardware version using the following procedure and refer to the **BCM50 Upgrade Flow Charts** section of this guide.

Use the following process to check the BCM CSC hardware version.

1. In the Element Manager **Administration** tab, open the **General** folder and select **Hardware Inventory**.

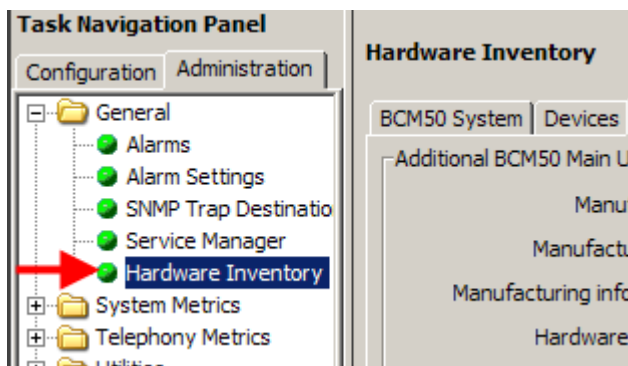

- Click on the **Additional Information** tab, and make a note of the **CSC Hardware** version.

**Hardware Inventory**

BCM50 System | Device | **Additional Information**

Additional BCM50 Main Unit Information

Manufacturer:	
Manufacture date:	2005-04-01 12:51
Manufacturing information:	00.0011F9E61B55.0011F9E61B56.0011F9E61B57.02.123456789A
Hardware version:	10.07
CSC CPC code:	NORNT9T6525_
CSC serial number:	NNTMHD00005I
<b>CSC hardware version:</b>	<b>1</b>
Hard disk drive description:	Maxtor 6E040T0
Hard disk drive PEC order code:	NT9T4009E5
Hard disk drive serial number:	E1220CXN
Hard disk drive firmware version:	NAN51680

- If the CSC hardware is version 1, please note the steps indicated in the **BCM50 Upgrade Flow Charts** section of this guide. The specific steps relating to CSC hardware version 1 models involve ensuring the BCM50 RIs 3.0 or 5.0 Factory Image is applied before upgrading to BCM50 RIs 6.0.

### ***Checking the Time Zone is Set Correctly***

Before any upgrade is performed, you should check that the Time Zone has been changed from the initial default setting, to the Time Zone of your locality. If the Time Zone is still set to Factory Default, it will not be possible to apply the upgrade files.

Use the following procedure to check the Time Zone setting.

- In the Element Manager **Configuration** tab, open the **System** folder and select **Date and Time**.

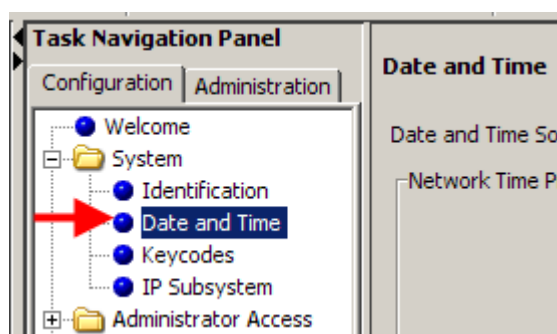

2. Check that the **Time Zone** field is set to your region, and is **not** set to Factory Default.

**Date and Time**

Date and Time Source:

Network Time Protocol Settings

NTP server address:

Synch every (s):

NTP security mode:

Raise alarm if clock differs by at least (s):

NTP key ID:

NTP key string:

Current Date and Time

Date and time:

Time zone:

Daylight Savings Time:

3. If the Time Zone is still set at Factory Default, select the correct Time Zone for your region.

### ***Checking the DHCP Server Setting***

Early versions of BCM50 offered the Enabled – Automatic setting for DHCP, which was designed to detect existing DHCP services on the network and configure the BCM to offer the appropriate DHCP services accordingly. The Enabled – Automatic setting is not available on later versions of BCM50 or BCM RIs 6.0. Therefore, you should check that the DHCP setting is set to one of the following, to ensure that when the BCM50 is upgraded to BCM RIs 6.0, the appropriate DHCP service for the network is provided by the BCM50.

The available modes on BCM RIs 6.0 are:

- Disabled – Does not respond to DHCP requests from any device.
- Enabled – IP Phones only – Only responds to DHCP requests from IP Phones.
- Enabled – All Devices – Responds to DHCP requests from PC's and IP Phones on the network.

Ensure that the BCM DHCP service is set to one of the above modes. If the DHCP mode is left in the Enabled – Automatic mode, after the upgrade the setting will automatically change to Enabled – IP Phones Only.

**Note:** This does not apply to the DHCP configured on the router card of the BCM50(b)e or BCM50(b)a models. If the DHCP service is enabled on the router card of these models, it should not be affected by the upgrade.

Use the following procedure to check the DHCP service setting for the BCM.

1. In the Element Manager **Configuration** tab, open the **Data Services** folder and select **DHCP Service**.

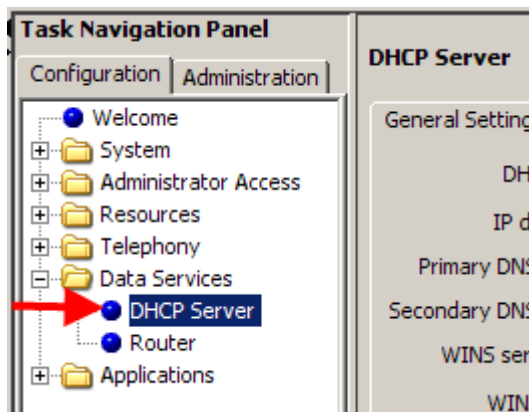

2. Select one of the available modes (i.e. not Enabled – Automatic).

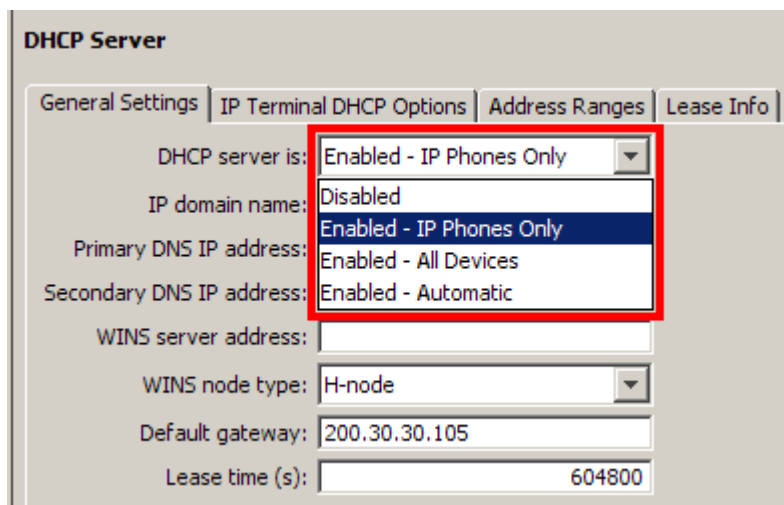

### ***Applying the Keycode File***

A keycode file containing the upgrade authorisation entitlement (upgrade to RIs 6.0 or first upgrade to RIs 3.0 if upgrading from RIs 1.0) should be applied to the BCM before applying the upgrade files.

When you have obtained the keycode file(s) containing the appropriate upgrade entitlement, apply the keycode using the following procedure.

1. In the Element Manager **Configuration** tab, open the **System** folder, and click on **Keycodes**.

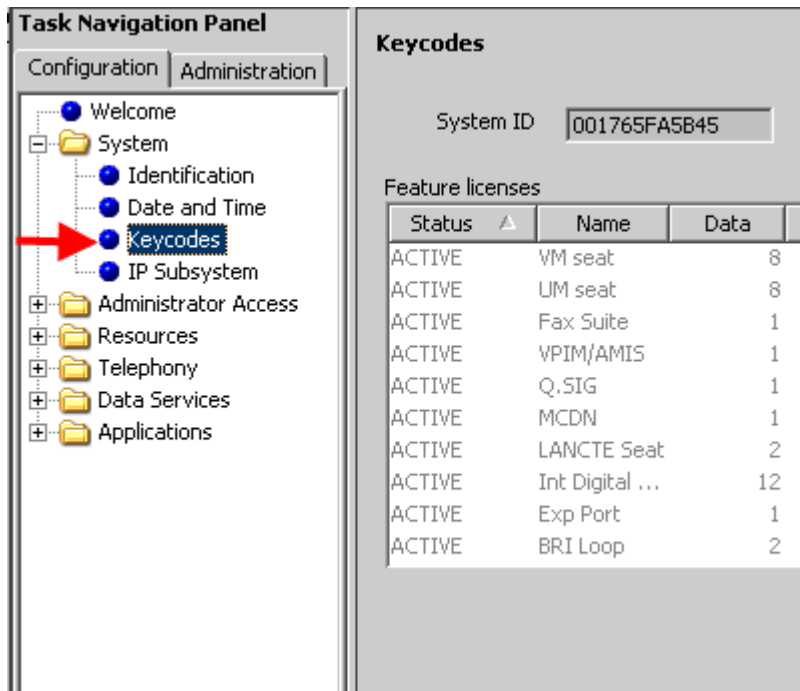

2. Click on the **Load File** button.

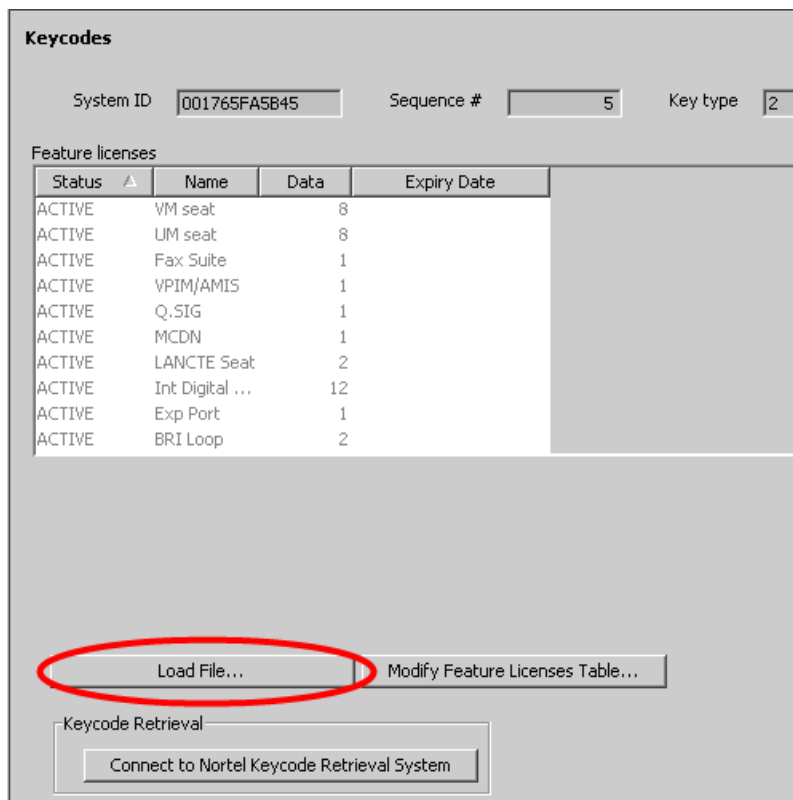



3. Browse to the location of the file and select it.

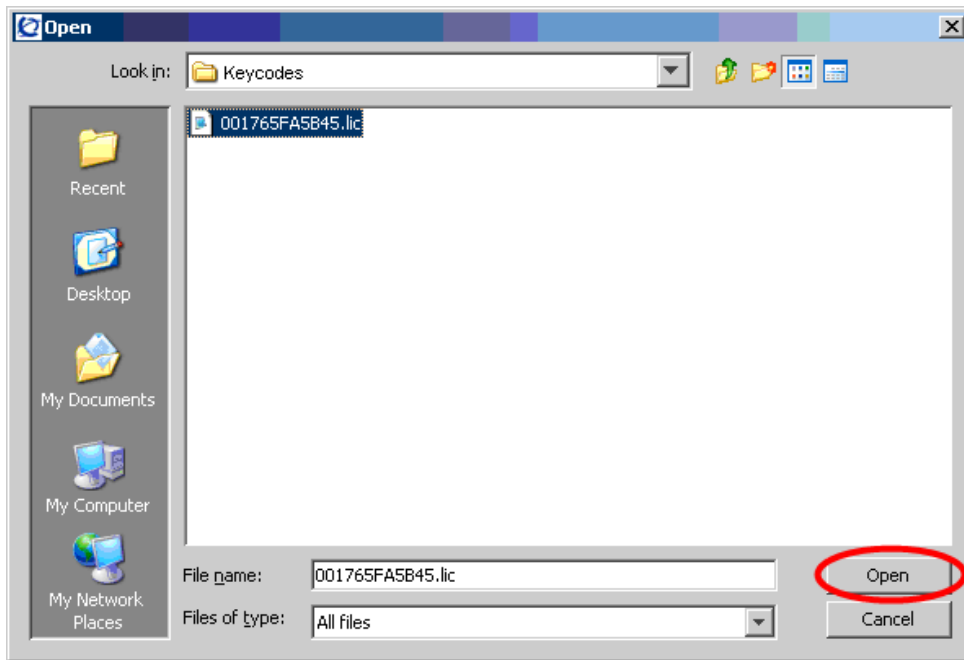

4. Click **Open**.
5. The new keycode file will be applied to the BCM50, allowing the software upgrade to be performed.

## Performing the Upgrade

You may receive your upgrade files on DVD or in zip format. If your files are in zip format, ensure they are extracted to an accessible location before proceeding with the upgrade.

**Note:** If the keycode containing the relevant upgrade entitlement has not been applied to the BCM, you will not be able to perform the upgrade.

**Note:** The upgrade process can take up to 65 minutes, during which some or all of the BCM services will be unavailable.

**Note:** Do not interrupt or power down the BCM during the upgrade process, as this could cause catastrophic failure to the BCM.

Use the following procedure to apply the upgrade files to the BCM.

1. In the Element Manager **Administration** tab, open the **Software Management** folder and select **Software Updates**.

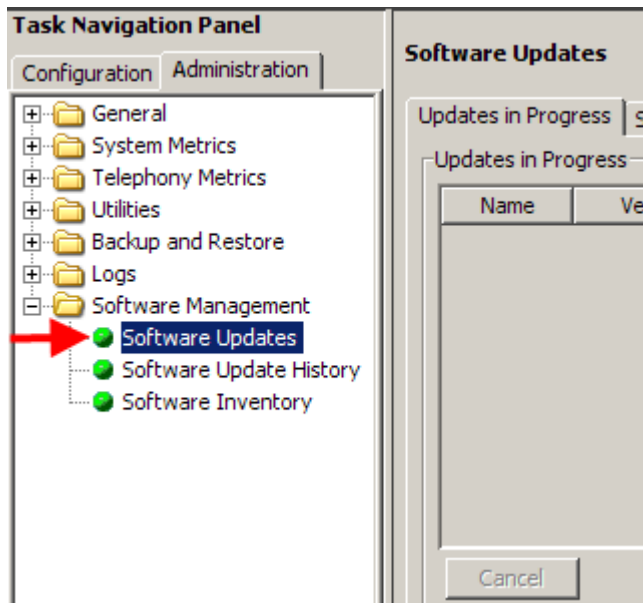

2. Click on the **Get New Updates** button to specify where the upgrade files are stored.

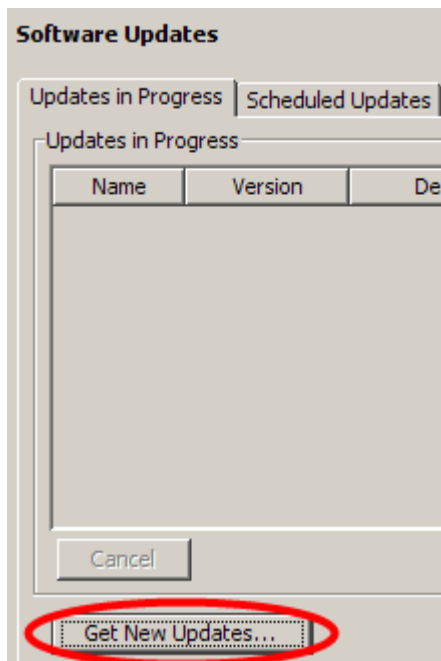

3. In the **Get New Updates** dialog box, select the location of the upgrade files from the **Retrieve from** drop-down list.

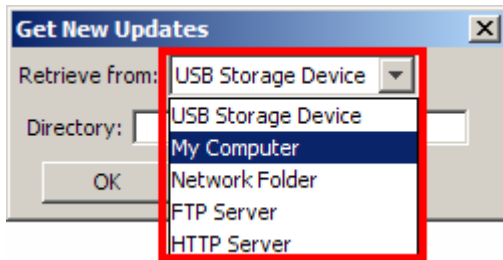

4. For Network Folder, FTP Server, and HTTP(s) locations, enter the location details of the upgrade files, and any specific security credentials for locations. Click **OK** when the details have been entered.

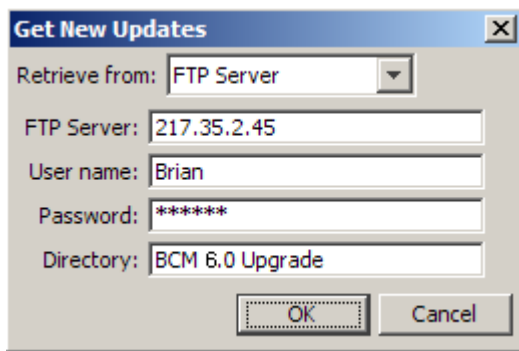

5. For the My Computer option (i.e. the upgrade files are stored on your PC/laptop from which you're performing the upgrade), click on the **Browse** button.

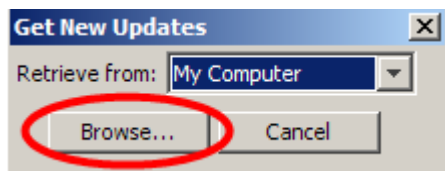

- Navigate to the folder containing the extracted upgrade files. Click on the folder itself (you do not need to select any specific or individual files) and click on **Select**.

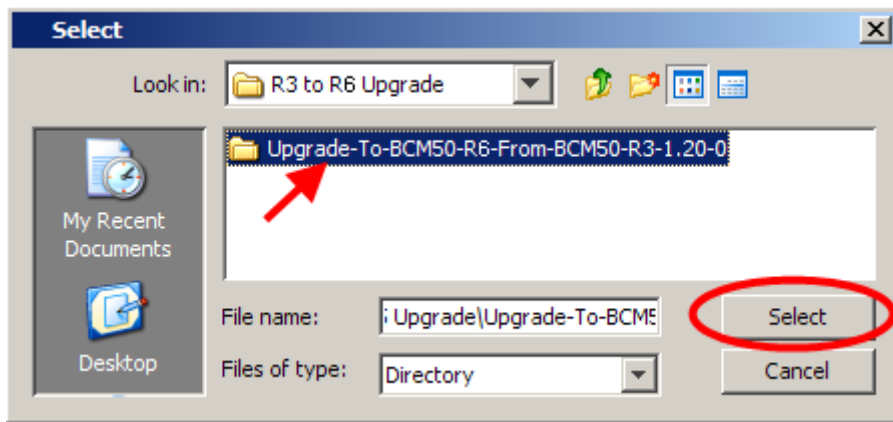

- Click on the appropriate upgrade, and click on **Apply**.

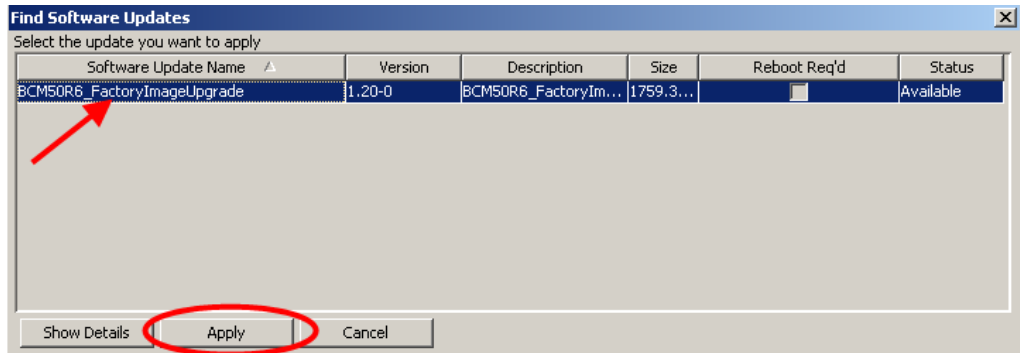

- Click **Yes** in the Confirm window.

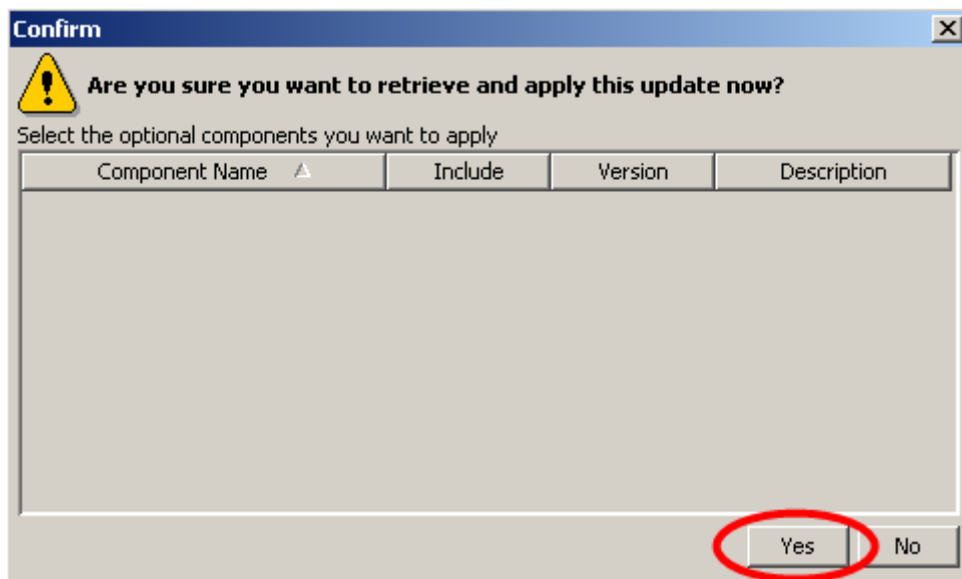

9. The upgrade files will then be uploaded to the BCM.

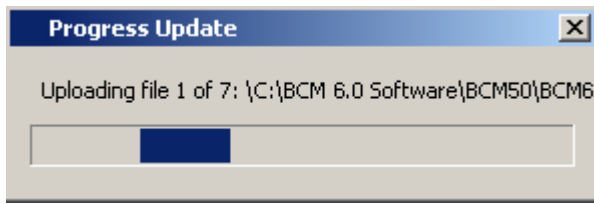

10. When uploaded, the files will be applied.

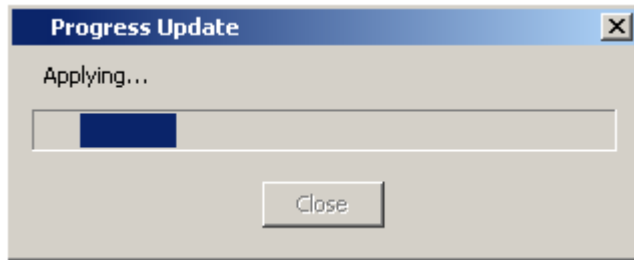

11. When the upgrade is complete, a confirmation box will display. Click **OK**.

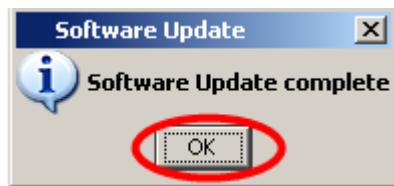

12. The system may automatically reboot if this is a requirement of the upgrade.

## Applying the Factory Image

When the BCM has been upgraded it is highly recommended to apply the Factory Image. This is the case when upgrading from RIs 1.0 to RIs 3.0, or RIs 2.0/3.0/5.0 to RIs 6.0. Applying the Factory Image will ensure that the BCM software version will not revert to its original state, if a Software Reset (also known as a Level 2 Reset) is performed on the BCM.

The Factory Image is applied using the same method as applying the upgrade files, i.e. in the **Administration** tab under **Software Management, Software Updates**. Refer to the **Performing the Upgrade** section for details of how to apply software updates.

Application of the Factory Image does not stop any BCM services or require a reboot of the system.

**Note:** Do not apply the Factory Image unless you are sure the upgraded system is functioning correctly. You will not be able to perform a Software Reset and restore a previous backup if the Factory Image is applied before checking system functionality.

## Post-Upgrade Activities

Below is an overview of activities once the BCM50 has been upgraded to BCM RIs 6.0, and the Factory Image has been applied:

- Apply any new patches, e.g. from the Smart Update DVD.
- Re-install client applications, including Element Manager. Refer to the relevant documentation for further information.
- Configure any new BCM RIs 6.0 features that you require (keycodes may be necessary to unlock some features).

## Avaya Documentation Links

- [Installation – System](#)
- [Upgrade Guide](#)

